

# RSSPLUS™ TRAILER ABS WITH ROLL STABILITY SUPPORT: 2S/2M AND 4S/2M

## MAINTENANCE MANUAL

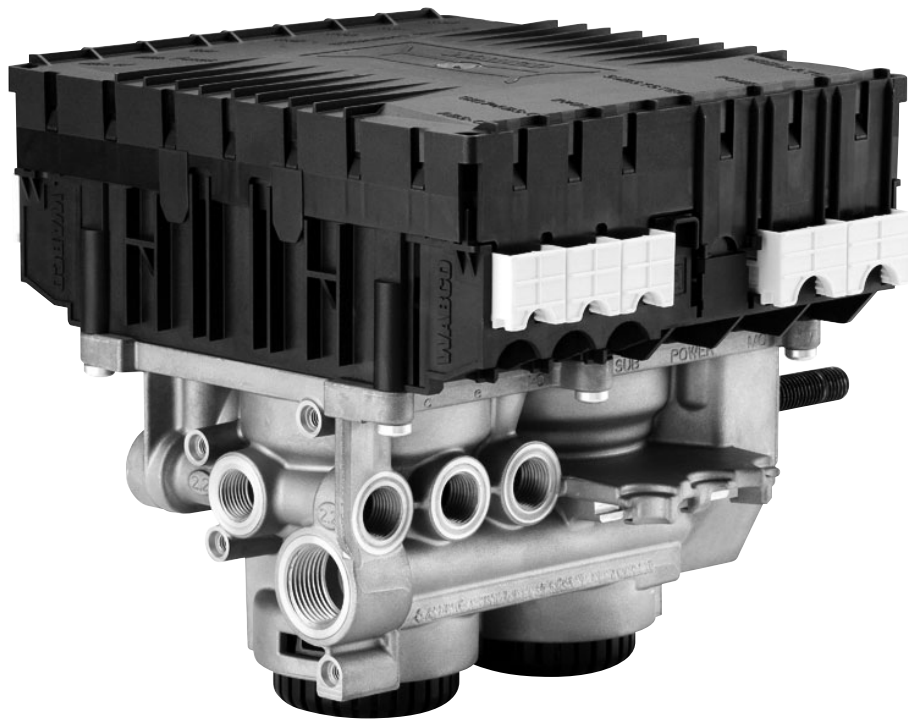

MM0888

**WABCO**

Mobilizing Vehicle Intelligence



# Table of Contents

## Table of Contents

<b>1</b>	<b>General Information</b> .....	<b>6</b>
<b>2</b>	<b>Safety Information</b> .....	<b>8</b>
	2.1 Trailer Ground and Protection from Electrostatic Discharge (ESD).....	9
<b>3</b>	<b>Introduction</b> .....	<b>11</b>
	3.1 Identification .....	11
	3.2 Description .....	13
<b>4</b>	<b>System Components</b> .....	<b>15</b>
	4.1 Hardware .....	15
	4.2 TOOLBOX™ Software .....	16
<b>5</b>	<b>ABS Questions and Answers</b> .....	<b>18</b>
	5.1 RSS <i>plus</i> Components and Features .....	18
	5.2 Roll Stability Support Questions and Answers.....	18
	5.3 Power Line Carrier (PLC) Communications Questions and Answers .....	19
	5.4 ABS Indicator Lamps .....	20
	5.5 Types of Faults.....	21
<b>6</b>	<b>System Configurations</b> .....	<b>23</b>
	6.1 RSS <i>plus</i> Installation Diagrams .....	23
	6.2 Multiple Trailer Applications .....	32
	6.3 Wiring Diagrams .....	35
<b>7</b>	<b>Diagnostics</b> .....	<b>36</b>
	7.1 Diagnostic Methods .....	36
	7.2 Important PLC Information for Blink Code Diagnostics.....	37
	7.3 TOOLBOX™ Software .....	37
	7.4 Blink Code Diagnostics .....	37
	7.5 Computer Diagnostics including TailGUARD .....	39

# Table of Contents

<b>8</b>	<b>Component Replacement</b> .....	<b>137</b>
8.1	Component Removal and Installation Procedures.....	137
8.2	Cable Connections.....	138
8.3	Wheel Speed Sensor.....	138
8.4	ECU/Valve Assembly.....	139
8.5	ECU/Dual Modulator Valve Assembly.....	142
8.6	Air Lines.....	143
8.7	Distance Sensor.....	143
8.8	Distance Sensor Extension Lever.....	146
<b>9</b>	<b>Sensor Adjustment and Component Testing</b> .....	<b>147</b>
9.1	Testing.....	147
9.2	Check ABS Functions.....	148
9.3	End of Line Testing.....	148
9.4	Putting the Trailer into Service.....	149
<b>10</b>	<b>Parameter Entry for RSS<i>plus</i></b> .....	<b>156</b>
10.1	Vehicle Parameter Records.....	156
10.2	Air Suspension Parameters.....	157
10.3	Mechanical Suspension Parameters.....	160
<b>11</b>	<b>Troubleshooting</b> .....	<b>165</b>
11.1	Lift Axle Troubleshooting.....	165
11.2	Tag Axle Troubleshooting.....	184
11.3	Tire Inflation Communication System Troubleshooting.....	196
11.4	Door Ajar System with RSS <i>plus</i> Troubleshooting.....	203
<b>12</b>	<b>Appendix</b> .....	<b>211</b>
12.1	Cable Routing Guidelines.....	212
12.2	Cable Strain Relief Guidelines.....	212
12.3	Vehicle Electrical Grounding Guidelines.....	215
12.4	Pin Assignment.....	216

**Edition 1**  
**Version 3 (09.2021)**  
**MM0888 (en)**

This publication is not subject to any update service. Information contained in this publication was in effect at the time the publication was approved for printing and is subject to change without notice or liability. ZF CV Systems North America LLC reserves the right to revise the information presented or to discontinue the production of parts described at any time.

You will find the current edition at: [www.wabco-na.com/literature](http://www.wabco-na.com/literature)



# General Information

## 1 General Information

### 1.1 Symbols Used in this Document

#### **DANGER**

Description of an immediate situation which will result in irreversible injury or death if the warning is ignored.

#### **WARNING**

Description of a possible situation which may result in irreversible injury or death if the warning is ignored.

#### **CAUTION**

Description of a possible situation which may result in irreversible injury if the warning is ignored.

#### **NOTICE**

Description of a possible situation which may result in material damage if the warning is ignored.

 Important information, notices and/or tips

 Reference to information on the Internet

Descriptive text

– Action step

1. Action step 1 (in ascending order)

2. Action step 2 (in ascending order)

⇒ Result of an action

• Listing

 Indicating the use of a tool / WABCO tool

## General Information

### 1.2 How to Obtain Additional Maintenance, Service and Product

If you have any questions about the material covered in this publication, or for more information about the WABCO product line, please contact WABCO Customer Care Center at 855-228-3203, by email at [wnacustomercenter@wabco-auto.com](mailto:wnacustomercenter@wabco-auto.com), or visit our website: [www.wabco-na.com](http://www.wabco-na.com).

Refer to the Society of Automotive Engineers (SAE) website to find all current SAE documents and standards applicable to WABCO products (such as SAE J447 and SAE J908 at [www.sae.org](http://www.sae.org)).

Refer to the National Highway Traffic Safety Administration (NHTSA) website to find all current documents referenced in the manual at [www.nhtsa.gov](http://www.nhtsa.gov).

### 1.3 How to Obtain Parts and Kits

Contact the WABCO Customer Care Center at 855-228-3203 (United States and Canada); 800-953-0248 (Mexico). Email: [wnacustomercenter@wabco-auto.com](mailto:wnacustomercenter@wabco-auto.com), [wabconorders@wabco-auto.com](mailto:wabconorders@wabco-auto.com) or [wabconaspecs@wabco-auto.com](mailto:wabconaspecs@wabco-auto.com).

### 1.4 WABCO TOOLBOX PLUS™ Software

TOOLBOX PLUS™ Software provides PC diagnostic for WABCO products and can be purchased and downloaded from <https://wabco.snapon.com>.

The software User Guide, MM19047 can be obtained by visiting our Literature Center.



Purchase and Download TOOLBOX PLUS™

<https://wabco.snapon.com>



WABCO Literature Center

[www.wabco-na.com/literature](http://www.wabco-na.com/literature)

### 1.5 WABCO Academy



[www.wabco-academy.com](http://www.wabco-academy.com)

### 1.6 WABCO Online Product Catalog



[www.wabco-customercenter.com/](http://www.wabco-customercenter.com/)

## General Information

### 1.7 Your Direct Contact to ZF CVCS

#### **ZF CV Systems North America LLC**

1220 Pacific Drive  
Auburn Hills, MI 48326

Customer Care Center: (855) 228-3203

[www.wabco-na.com](http://www.wabco-na.com)

# Safety Information

## 2 Safety Information

### Provisions for a safe work environment

- Only experienced, trained and qualified automotive technicians may carry out work on the vehicle.
- Read this publication carefully.
- Follow all warnings, notices and instructions to avoid personal injury and property damage.
- Always abide by the vehicle's Original Equipment Manufacturer (OEM) specifications and instructions.
- Observe all accident regulations of the repair facility as well as regional and national regulations.
- The workplace should be dry, sufficiently lit and ventilated.
- Use personal protective equipment if required (safety shoes, protective goggles, respiratory protection and ear protectors).

Read and observe all Danger, Warning and Caution hazard alert messages in this publication. They provide information that can help prevent serious personal injury, damage to components, or both.

#### **WARNING**

To prevent serious eye injury, always wear safe eye protection when you perform vehicle maintenance or service.

#### **WARNING**

Park the vehicle on a level surface. Block the wheels to prevent the vehicle from moving. Support the vehicle with safety stands. Do not work under a vehicle supported only by jacks. Jacks can slip or fall over. Serious personal injury and damage to components can result.

#### **WARNING**

This product can expose you to chemicals including Nickel, which is known to the State of California to cause cancer and birth defects or other reproductive harm. For more information, go to [www.P65Warnings.ca.gov](http://www.P65Warnings.ca.gov).

# Safety Information

## 2.1 Trailer Ground and Protection from Electrostatic Discharge (ESD)

### CAUTION

Unintended voltages induced into the electronic control unit can damage the ECU. Disconnect all connectors from the ECU before you perform any welding, electrostatic painting, or any other activity that applies high voltage to the vehicle frame. Refer to the equipment manufacturer's recommended instructions for correct procedures..

Prevent potential resistance differences in grounding between components (such as axles) and the vehicle frame (chassis).

Make sure that the resistance between metallic parts of the components connected to the trailer frame is less than 10 Ohm ( $< 10\Omega$ ).

Connect moving or insulated vehicle parts (such as axles) in a electrically conductive manner with the frame.

Ensure a secure and adequate chassis ground at the J560 seven-way connector ground pin on the trailer.

Use electrically conductive bolted connections when fastening the ECUs to the trailer frame.

### 2.1.1 Welding Work on the Trailer

Disconnect power to the trailer.

Disconnect all cable connections to devices and components and protect the plug-ins and connections from contamination and humidity.

Always connect the grounding electrode directly with the metal next to the welding position when welding, to prevent magnetic fields and current flow via the cable or components.

Make sure that grounding connections are robust by removing paint or rust at the connection points.

Prevent heat influences from the welding activity on devices and cabling when welding.

**During Electrostatic Painting the Trailer Frame or Bogie:** Disconnect all cable connections to devices and components and protect the plug-ins and connections from contamination and humidity.

### 2.1.2 Dielectric Grease

All Enhanced Easy-Stop ECUs and ECU/valve assemblies with a production date of 1515 or later have NyoGel 760G grease applied. Nyogel 760G is the only grease approved for use on the power, modulator and sensor extension cables of the Enhanced Easy-Stop ABS System. The grease is pre-applied to the ECU sensor O-ring, the power/modulator cable terminals and the sensor extension cable terminals. Additional grease must not be applied to the ECU's sensor input connectors at a manufacturing or service facility level.

On ECUs manufactured prior to production date 1515, a thin coating of Nyogel 760G can be applied to the 8-pin terminals of the power and modulator cables as well as the male terminal pins on the sensor extension cable. Ensure the greased cables are free from dirt and debris before installation, as the grease readily collects dirt, debris or dust, which may inhibit functionality.

# Safety Information

## 2.1.3 Vehicle Electrical Grounding Guidelines

Ensure that the vehicle includes a correct common chassis ground point. A common chassis ground point connects the trailer frame/chassis to the ground pin of the J560 seven-way connector and will protect the vehicle electrical system from unwanted electrical noise.

Common chassis ground can be verified by measuring the resistance between the J560 ground pin and the vehicle chassis (or frame) and confirming that the resistance is less than 10 ohm ( $< 10 \Omega$ ). If this is not the case, the electrical contact at the common chassis ground point is not sufficient or not present. If a common chassis ground point is present, but not sufficient, ensure that there is no paint or debris inhibiting electrical contact at the ground point. If a common chassis ground point is not present, WABCO requires adding one. Consult your trailer manufacturer (OEM) for further instructions on how to perform this task. This ensures that the trailer OE warranty is not voided.



Do not add more than one common chassis ground point (connecting the J560 ground pin to the chassis) to avoid potential ground shifts within the vehicle electrical system.

Additionally, all standard trailer components, such as axles, should also be electrically connected to the common chassis ground. If the axles are not correctly grounded to the chassis, a ground strap electrically connecting the axle to the chassis must be added to ensure adequate protection from unwanted electrical noise. This can be verified by measuring the maximum resistance between the vehicle chassis/frame and the other trailer component, then confirming that the resistance is less than 10 ohm ( $< 10 \Omega$ ).

For more details concerning correct vehicle grounding, reference SAE standard J1908.

## Introduction

### 3 Introduction

This manual contains service and diagnostic information for WABCO *RSSplus*<sup>™</sup> Trailer ABS with Roll Stability Control.

#### 3.1 Identification

To identify *RSSplus*<sup>™</sup>, check the identification tag on the Electronic Control Unit (ECU). The part number is 480 107 001 0.

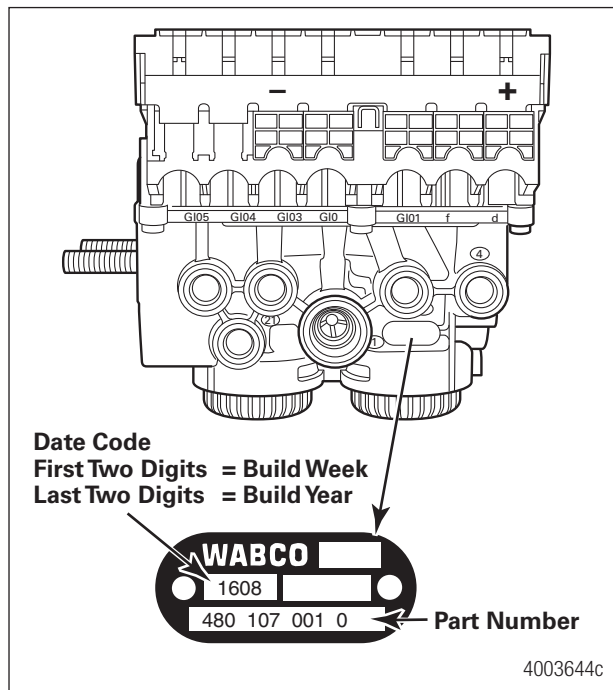

##### 3.1.1 *RSSplus* Trailer ABS Parts

A list of WABCO *RSSplus* parts can be found in Table A.

For warranty information, contact the WABCO Customer Care Center at 855-228-3203 and ask for TP99128, WABCO Trailer ABS Warranty Procedure.

# Introduction

**TABLE A: RSSplus Parts List**

Item	Nomenclature	Detail
100 001 012 4	RSS Label	Adhesive
100 400 004 0	Axle Clamp	5.8" Diameter
431 700 001 0	Pressure Switch Over Ride	70 psi
432 500 005 0	In-Line Filter	
441 044 106 0	Transducer	15 bar (1/4" NPTF)
441 050 100 0	Distance Sensor	
441 050 712 2	Distance Sensor Linkage	
441 050 718 2	Extension Lever	Old Style
441 901 715 4	Extension Lever	Current Style
449 351 010 0	Power Cable	1 Meter
449 351 047 0	Power Cable	4.7 Meters
449 443 030 0	ATC Generic I/O Cable	3 Meters
449 446 020 0	Generic I/O Cable	5 Meters
449 535 020 0	Generic I/O Cable	2 Meters
449 535 040 0	Generic I/O Cable	4 Meters
449 535 060 0	Generic I/O Cable	6 Meters
449 639 030 0	Diagnostic Cable	3 Meters
449 639 050 0	Diagnostic Cable	5 Meters
449 723 018 0	Sensor Extension Cable	1.8 Meters
449 723 030 0	Sensor Extension Cable	3 Meters
449 723 051 0	Sensor Extension Cable	5.1 Meters
449 723 120 0	Sensor Extension Cable	12 Meters
449 723 170 0	Sensor Extension Cable	17 Meters
449 810 148 0	Solenoid Y Cable	3 Meters
449 811 020 0	Distance Sensor Cable	2 Meters
449 812 100 0	Transducer Cable	10 Meters
480 102 931 2	Cable Clip Repair Kit	1 Large, 1 Small
480 107 000 0	RSSplus™ ECU	4S/2M-2S/2M
884 490 443 0	Tire Inflation I/O Cable	1 Meter
894 590 075 0	LA "Y" Cable	0.4 Meter
894 607 434 0	Stoplight Activation Cable	1 Meter
898 020 462 2	ECU Cable Port Plug	Large
898 020 463 2	ECU Cable Port Plug	Small
899 201 833 4	Power Label	Adhesive
934 099 010 0	Double Check QRV Combination Valve	
934 099 025 0	Select High Double Check Valve	
934 190 008 4	Breather Valve	
TP95172	ABS Label	Adhesive



# Introduction

## 3.2 Description

### 3.2.1 What Is WABCO's RSSplus™ Trailer ABS?

WABCO's RSSplus™ Trailer ABS is an electronic, self-monitoring system that works with standard air brakes. In addition, RSSplus™ includes Power Line Carrier (PLC) capability, Controller Area Network (CAN) capability and Roll Stability Support. The major components of the system are the **Electronic Control Unit (ECU)/Valve Assembly, tooth wheel and wheel speed sensor.**

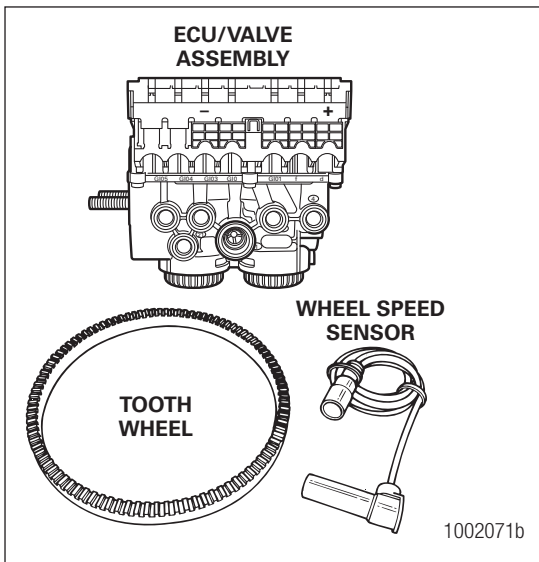

### 3.2.2 System Configuration

The ABS **configuration** defines the number of wheel speed sensors and ABS modulator valves used in a system. For example, a **2S/2M** configuration includes two wheel sensors and two ABS modulator valves. A **4S/2M** configuration includes four wheel sensors and two ABS modulator valves.

### 3.2.3 How Trailer ABS Works

WABCO ABS is an electronic system that monitors and controls wheel speed during braking. The system works with standard air brake systems.

ABS monitors wheel speeds at all times and controls braking during wheel lock situations. The system improves vehicle directional stability and control by reducing wheel lock during braking.

The ECU receives and processes signals from the wheel speed sensors. When the ECU detects a wheel lockup, the unit activates the appropriate modulator valve, and air pressure is controlled.

The RSSplus™ ECU provides additional assistance in maintaining trailer directional stability with Roll Stability Support. Combining the data received from the wheel sensors and an internal lateral accelerometer, the RSSplus™ will proactively engage the Roll Stability Support to increase trailer stability and reduce the possibility of a rollover condition.

In the event of a malfunction in the system, the ABS in the affected wheel(s) is disabled; that wheel still has normal brakes. The other wheels keep the ABS function.

Two ABS indicator lamps (one on the dash and one on the side of the trailer) let drivers know the status of the system.

## Introduction

### **WARNING**

RSS is an advanced vehicle control system from WABCO that reduces chances of a rollover and assists the driver in maintaining control of the vehicle. However, any vehicle may overturn in some situations with or without RSS.

### **WARNING**

Having *RSSplus*<sup>™</sup> does not allow drivers to take unnecessary risks. Make sure drivers do not take curves or turns faster than they would without *RSSplus*<sup>™</sup> and always use safe driving techniques. Failure to do so can result in serious personal injury, damage to components, or both. An alert unimpaired driver remains the primary element in maintaining control of the vehicle and reducing the chances of rollover accidents.

# System Components

## 4 System Components

### 4.1 Hardware

The various system component parts consist of the following:

#### 4.1.1 ECU/Valve Assembly

- 12 volt
- Integrated ECU and ABS relay valve
  - ECU and valve assembly are serviceable items.
- The ECU/Valve Assembly may be mounted with the sensors facing either the front or rear of the trailer.

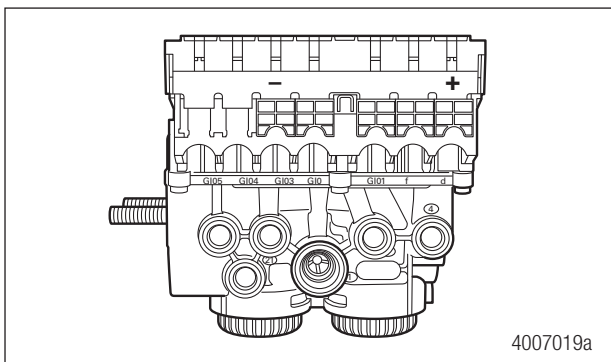

#### 4.1.2 Sensor with Molded Socket

- Measures the speed of a tooth wheel rotating with the vehicle wheel.
- Produces an output voltage proportional to wheel speed.

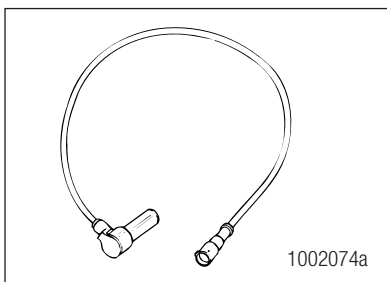

#### 4.1.3 Sensor Spring Clip

- Holds the wheel speed sensor in close proximity to the tooth wheel.

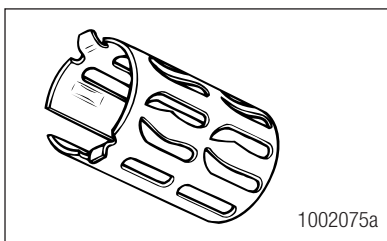

# System Components

## 4.1.4 Tooth Wheel

- A machined ring mounted to the machined surface on the hub of each ABS-monitored wheel.

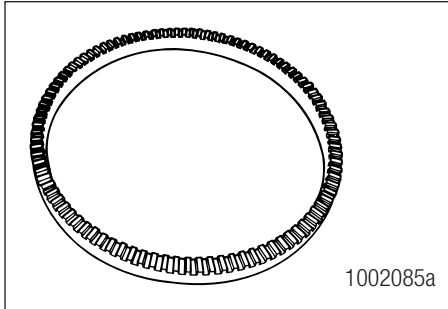

## 4.1.5 Cables for RSSplus

### RSSplus Trailer ABS Indicator Label

- Provides information about the operation of the ABS indicator lamp and illustrates blink code fault locations.
- Label is self-adhesive and is mounted on the trailer near the ABS indicator lamp.
- If there is no warning label on your trailer, let your supervisor know. Labels are available from WABCO. Ask for Part Number 100 001 012 4.

## 4.2 TOOLBOX™ Software

TOOLBOX™ Software is a PC-based diagnostics program that can display wheel speed data, test individual components, verify installation wiring and is required to perform a sign-off for the RSSplus™ installation.

WABCO TOOLBOX™ Software, Version 12.2 (or higher) supports RSSplus™ with PLC and runs on Windows 7, 8, 10 OS Systems. TOOLBOX™ Software is available for purchase via download 24 hours a day, seven days a week on <https://wabco.snapon.com/>.

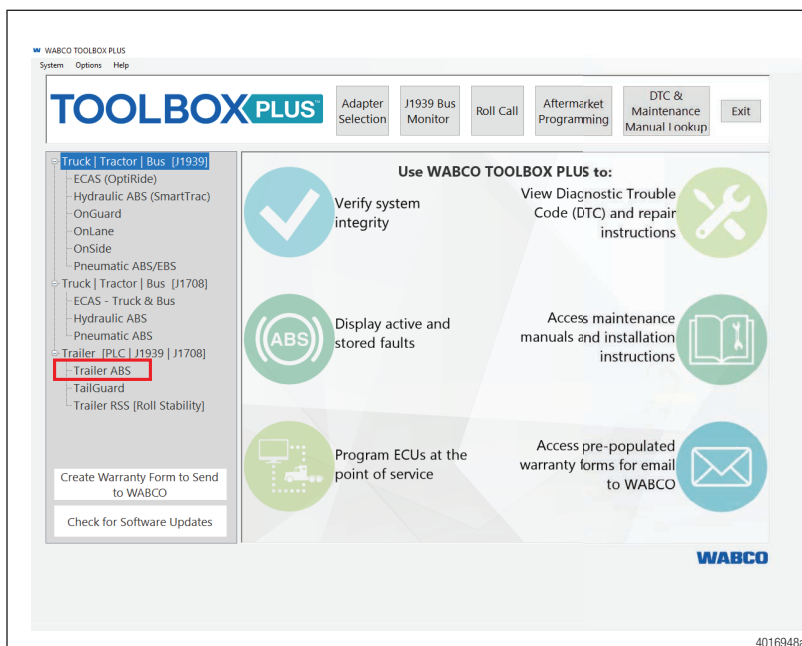

# System Components

## 4.2.1 PLC/J1708 Adapter

- Simulates the tractor ABS lamp, ensuring that the trailer ABS is capable of "lighting the light."
- Simulates the trailer ABS lamp, ensuring that the tractor is capable of "lighting the light."
- Use as a trailer/tractor tester to ensure that PLC is functioning correctly.

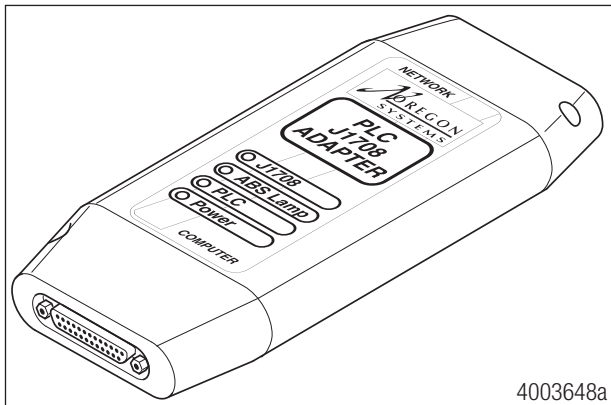

## 4.2.2 DLA + PLC Adapter

- Simulates the trailer ABS lamp, ensuring that the tractor is capable of "lighting the light."
- Use as a trailer/tractor tester to ensure that PLC is functioning correctly.

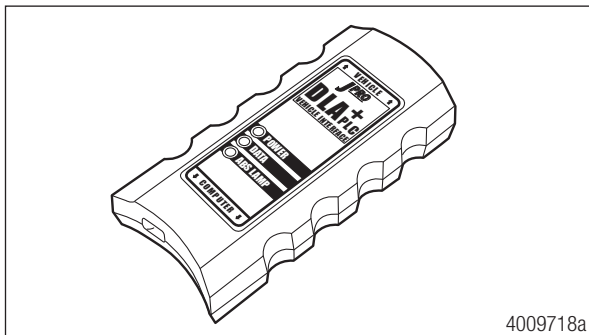

Available from [jprofleetproducts.com](http://jprofleetproducts.com), kit number 12204

## ABS Questions and Answers

### 5 ABS Questions and Answers

#### 5.1 *RSSplus* Components and Features

##### 5.1.1 The Electronic Control Unit (ECU)

***How do you activate the ECU?***

In a constant-powered system, the ECU activates and then begins a self-diagnostic check of the system when you turn the ignition ON. In a stoplight-powered system, the ECU activates when you apply the brakes. All trailers manufactured on or after March 1, 1998 will be equipped with ABS that has constant power capability with stoplight power as back-up.

***How does the ECU respond to a wheel approaching lock-up?***

The ECU directs the ABS relay valve to function as a modulator valve and adjust air pressure to the chambers up to five times a second. This pressure adjustment allows a wheel (or wheels) to rotate without locking.

#### 5.2 Roll Stability Support Questions and Answers

***What is Roll Stability Support?***

Roll Stability Support (RSS) is an integrated capability in the *RSSplus*<sup>™</sup> ECU that helps reduce the chances of a trailer rollover. By monitoring the trailer's speed, braking and side-to-side acceleration, the *RSSplus*<sup>™</sup> assists the driver in avoiding a potential rollover condition.

***How does it work?***

The *RSSplus*<sup>™</sup> ECU continuously monitors the trailer's wheel speed and lateral acceleration. When the ECU detects a potentially unstable condition, it requests data from the suspect wheels with a test pulse. The trailer's reaction to the test pulse determines whether normal braking, ABS braking, or Roll Stability braking is required. The test pulse is not generated under normal braking conditions.

***Will trailers with Roll Stability Support work with tractors that have standard ABS only?***

Yes. WABCO's trailer Roll Stability Support systems will work with standard tractor ABS made by different manufacturers.

***Will trailers with Roll Stability Support work with trailers that have standard ABS only?***

Yes. WABCO's trailer Roll Stability Support systems will work with non-Roll Stability Support ABS systems. Additional pneumatic considerations are shown in Section 4. Plumbing a non-Roll Stability Support ABS system with a Roll Stability Support system can easily be accomplished by following the patented WABCO P5 plumbing instructions.

RSS is permitted on the B-train configuration, as this configuration provides maximum stability support. Contact the WABCO Customer Care Center at (855) 228-3203 for additional information relating to pneumatic considerations for this configuration.

# ABS Questions and Answers

## 5.3 Power Line Carrier (PLC) Communications Questions and Answers

### ***What is PLC communications?***

PLC stands for Power Line Carrier, which is a method used to communicate information by multiplexing data on the same wire used for the ABS electrical power. PLC communications convert signal message data to a radio frequency (RF) signal on top of the +12V power line providing electrical power to the trailer.

### ***What is multiplexing?***

Multiplexing means communicating multiple signals or messages on the same transmission media. This provides an efficient and cost effective means by decreasing the number of wires and connectors which otherwise would be needed. Without multiplexing, it could take several wires and connections in order to transmit several different signals to various locations on a vehicle, but with multiplexing these wires and connectors can be significantly reduced.

### ***Why add PLC technology to tractor and trailer ABS?***

By adding PLC technology to the tractor and trailer ABS the industry is able to have the most cost effective means to meet the March 1, 2001 FMVSS-121 in-cab trailer indicator lamp mandate with no additional external hardware, harnesses or connectors. Additionally, this new capability of communicating other information between tractor and trailers provides many more opportunities to further improve productivity and safety. With every tractor and trailer currently built having ABS technology, integrating PLC technology into the PC board was the logical choice.

### ***How does it work?***

The trailer ABS with PLC takes message information to be sent to the tractor and converts it to an RF signal. The signal is then sent over the trailer ABS power line (blue wire) and the tractor ABS with PLC receives the signal. Messages can also be sent from the tractor to the trailer via PLC.

### ***What if a tractor is equipped with PLC technology and the trailer is not, or vice-versa? Will the tractor and trailer ABS function correctly?***

Yes. If the tractor is equipped with PLC and the trailer is not, or vice-versa, your ABS in-cab trailer indicator lamp will not illuminate, but your ABS will continue to function as normal. To ensure that the trailer ABS is functioning correctly, the trailer ABS indicator lamp mounted on the trailer should be utilized.

### ***What if a tractor has one manufacturer's ABS with PLC and the trailer has another manufacturer's ABS with PLC? Will the two systems be compatible and operate the trailer ABS lamp as expected?***

Yes. ABS with PLC from different manufacturers are designed to be compatible by controlling the trailer ABS lamp according to the FMVSS-121 standard, even when systems from different manufacturers are connected to each other. However, certain features beyond the control of the trailer ABS indicator lamp may or may not be supported by all devices communicating via PLC. SAE task forces continue to standardize common messages so that maximum compatibility may exist in the future.

### ***How do I diagnose PLC?***

PLC can be diagnosed over the J1587/J1708 diagnostic connector on the tractor or on the trailer using tools designed for PLC diagnostics.

### ***Can I use blink code diagnostics on Enhanced Easy-Stop™ to diagnose PLC?***

Yes. Section 7 of this manual describes the method of performing a blink code check using Constant Power (ignition activation). Blink Code 17 indicates a PLC failure.

### ***If PLC does not seem to be operating correctly, but I don't get a Blink Code 17 when I run a blink code check, what else could be wrong?***

If there is no Blink Code 17, the PLC is functioning correctly and does not need to be replaced; however, there could be a problem in the trailer's wiring harness. Check the wiring system and make the necessary repairs. If the problem persists, contact WABCO for assistance.

# ABS Questions and Answers

## 5.4 ABS Indicator Lamps



When replacing the bulb, to ensure correct lamp operation use an incandescent type DOT-approved lamp, or a LED with integral load resistor.

### 5.4.1 ABS Indicator Lamp (on Dash)

With RSSplus™, there are two ABS indicator lamps; one on the vehicle dash and one on the side of the trailer.

### 5.4.2 ABS Indicator Lamp (on Trailer)

#### *What is the function of the ABS indicator lamp?*

The indicator lamp enables a driver to monitor the ABS at all times. Refer to the OEM operating manual for the mounting location of the indicator lamp.

#### *How does the indicator lamp operate?*

How the indicator lamp operates depends on whether the ABS is powered by stoplight or constant power:

- If the trailer was manufactured prior to February 28, 1998, or was manufactured outside of the United States, the ABS may be either stoplight or constant powered.
- If the trailer was manufactured March 1, 1998 or later — and was manufactured in the United States — it will have constant power capability. This is mandated by Federal Motor Vehicle Safety Standard (FMVSS) 121.

Check your vehicle specification sheet to determine the type of ABS power. Table B in this section illustrates indicator lamp operation on constant powered ABS systems.

#### *What does the trailer ABS indicator lamp mean to service personnel?*

The trailer ABS indicator lamp on the side of the trailer indicates the status of the trailer ABS. If it comes ON and stays ON when you apply the brakes to a moving vehicle, there is an ABS malfunction. It is normal for the lamp to come ON and go OFF to perform a bulb check, but it should not stay ON when the vehicle is moving above 4 mph (6.45 kph). As with any safety system, it is important not to ignore this indicator. If the indicator lamp indicates a malfunction, the vehicle can be operated to complete the trip, but it is important to have it serviced as soon as possible using the appropriate maintenance manual to ensure correct braking performance and that the benefits of ABS remain available to your drivers. Typical ABS indicator lamp mounting locations are illustrated.



# ABS Questions and Answers

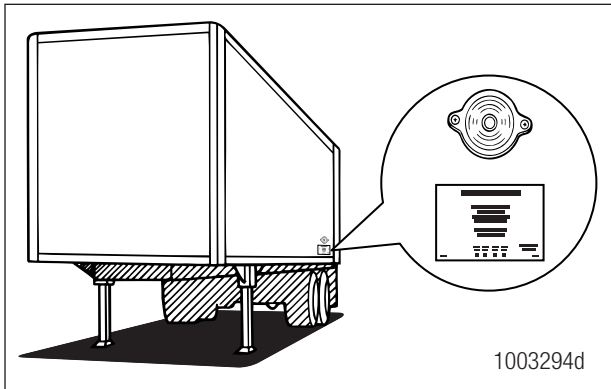

## Typical ABS Indicator Lamp Mounting Location on Side of Trailer

For more information, contact the WABCO Customer Care Center at 855-228-3203.

### *Can you continue to operate a vehicle when the indicator lamp indicates a fault?*

Yes. When a fault exists in the ABS, standard braking returns to the affected wheel, and the ABS still controls other monitored wheels. This lets you complete the trip. You should not ignore the indicator lamp and should have the vehicle serviced as soon as possible after the lamp comes ON and stays ON. Indicator lamp operation is shown in Table B.

**TABLE B: Constant Power, System is Ignition Powered**

System is Ignition Powered				
Brakes	Ignition	Fault in System	Vehicle Speed	Indicator Lamps (Trailer and Dash)
Released	OFF	N.A.	N.A.	OFF
	ON	NO	Less than 4 mph (6.45 kph)	ON for three seconds, then go OFF.
	ON	NO	Greater than 4 mph (6.45 kph)	OFF
Applied	ON	YES	N.A.	ON
	OFF	NO	Less than 4 mph (6.45 kph)	ON for three seconds, then go OFF
	OFF	YES	N.A.	ON
	ON	NO	Less than 4 mph (6.45 kph)	ON for three seconds, then go OFF
	ON	NO	Greater than 4 mph (6.45 kph)	OFF
	ON	YES	N.A.	ON

## 5.5 Types of Faults

### *What is a "fault" in the system?*

A fault in the system is a problem that can exist in the ABS or in the system's components. Faults can be either existing faults or intermittent stored faults.

### *What is an existing fault?*

An **existing** fault is a problem that exists currently in the system. For example, a damaged sensor cable is an existing fault that the ECU will detect and store into memory until you identify the cause, repair the cable and clear the fault from the ECU. An existing fault is also referred to as an "active" fault.

# ABS Questions and Answers

## ***What is an intermittent fault?***

An **intermittent** fault is a problem that usually occurs only under certain driving conditions. For example, the ECU may detect a loose cable or wire or receive an erratic signal from a wheel sensor. Since intermittent faults can be unpredictable and may only happen periodically, you can use information stored in ECU memory to find and correct the loose cable or wire. An intermittent fault cannot be retrieved using blink codes. An intermittent fault is also referred to as a "stored" fault.

## ***Is an intermittent fault difficult to locate and repair?***

It can be, because you may not be able to easily see the cause of the problem. WABCO recommends that you write down intermittent faults to help you isolate a fault that recurs over a period of time.

## ***Can the ECU store more than one fault in memory?***

Yes. And the ECU retains existing and intermittent faults in memory even when you turn OFF the power to the ECU.

## ***What if the ECU finds a fault in an ABS component during normal operation?***

If the ECU senses a fault in the system (with an ABS valve, for example), the ECU turns the trailer ABS indicator lamp on and returns the wheel controlled by that valve to standard braking. Or, if the ECU finds a fault with one wheel speed sensor in a system that has four sensors on a tandem axle, the ECU uses information from the other sensor on the same side of the tandem to ensure continuous ABS function. The ECU continues to provide full ABS function to the wheels unaffected by system faults. However, the ECU will turn the trailer ABS indicator lamp on to tell the driver a fault has been detected in the system.

# System Configurations

## 6 System Configurations

### 6.1 RSSplus Installation Diagrams

With RSSplus™, standard 2S/2M and 4S/2M sensor location designations will change depending on how the ECU/dual modulator valve assembly is mounted. It may be mounted facing either the front or the rear of the trailer. It is important that you identify the location of these sensors before beginning any diagnostics. Sensor locations for both front and rear-facing installations are depicted in this section. Refer to Table C.



RSSplus™ can only be installed with the 2 modulator valves controlling each side of the trailer brakes. Never install the valve controlling the trailer brakes axle to axle. Figure 6.1 through Figure 6.11.

**Table C: Sensor Locations**

Configuration	Figure Reference
2S/2M Standard Mounted with Sensors Facing Front of Trailer	Figure 6.1 and Figure 6.3.
2S/2M Standard Mounted with Sensors Facing Rear of Trailer	Figure 6.2 and Figure 6.4.
4S/2M Premium Mounted with Sensors Facing Front of Trailer	Figure 6.5 and Figure 6.7.
4S/2M Premium Mounted with Sensors Facing Rear of Trailer	Figure 6.6 and Figure 6.8.

# System Configurations

## 5.5.1 Typical RSSplus Trailer ABS Installations

**i** WABCO recommends placing the sensors on the axle that will provide the most braking performance. This is based on the way the suspension reacts during heavy braking applications. The trailer manufacturer can provide this information. The following Figures 6.1 through Figure 6.11 are recommendations for many of the standard trailers built in North America.

Fig. 6.1

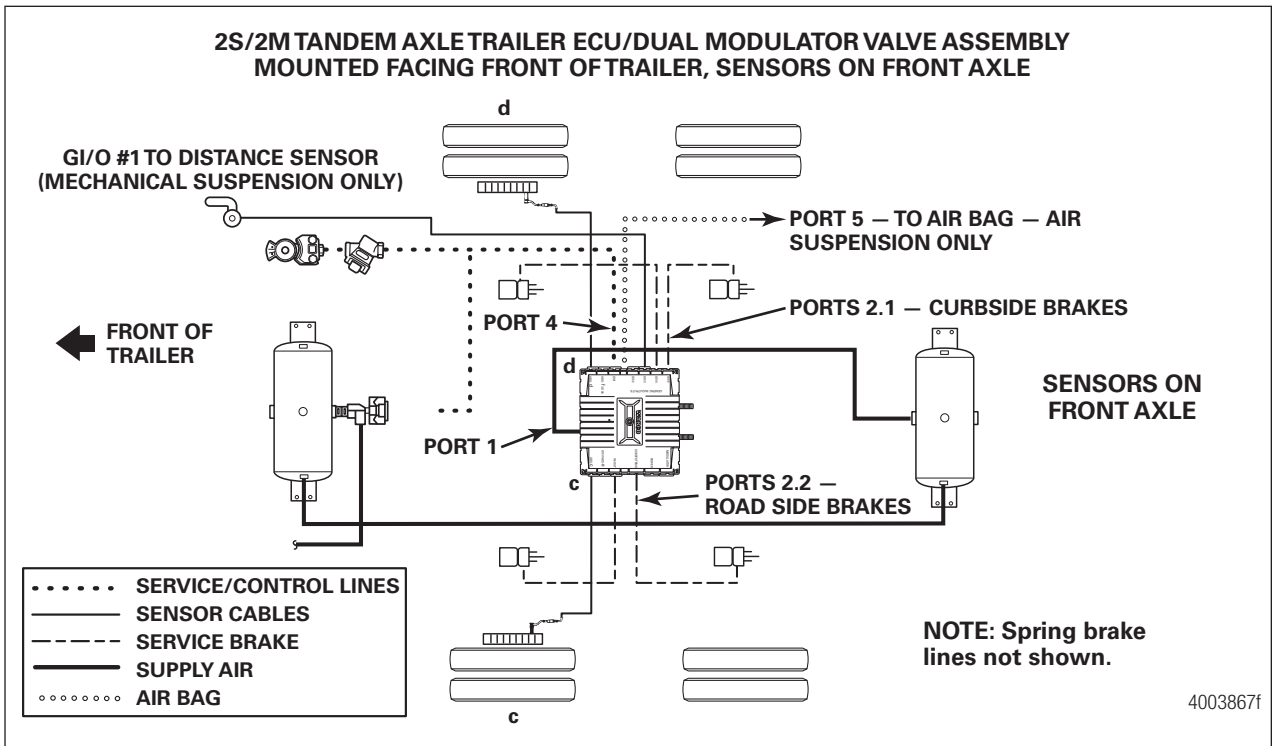

# System Configurations

Fig. 6.2

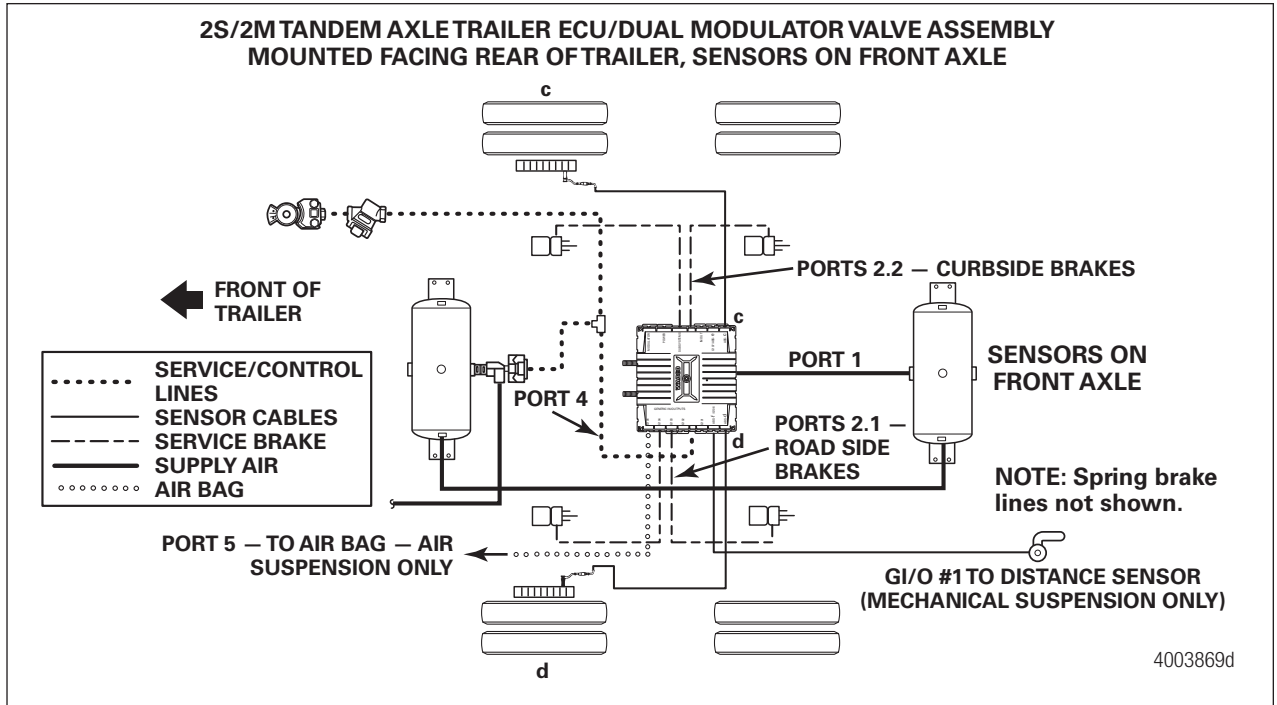
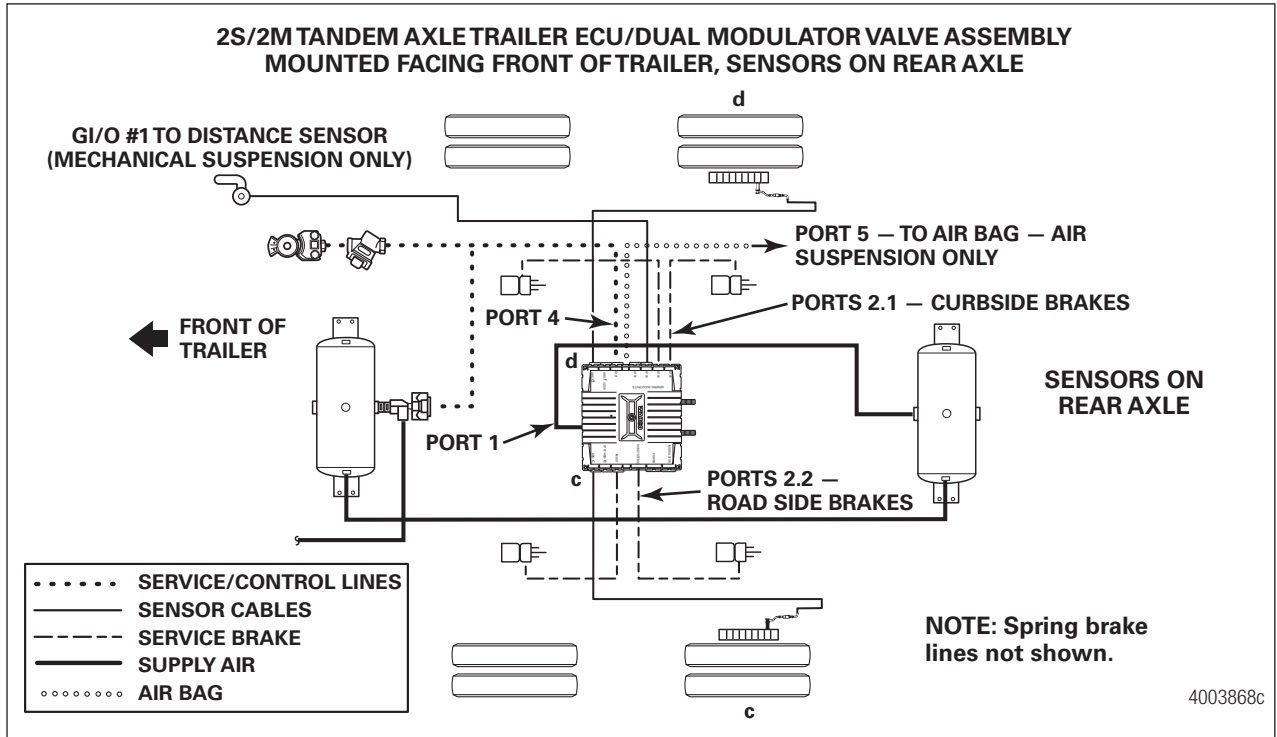

Fig. 6.3



# System Configurations

Fig. 6.4

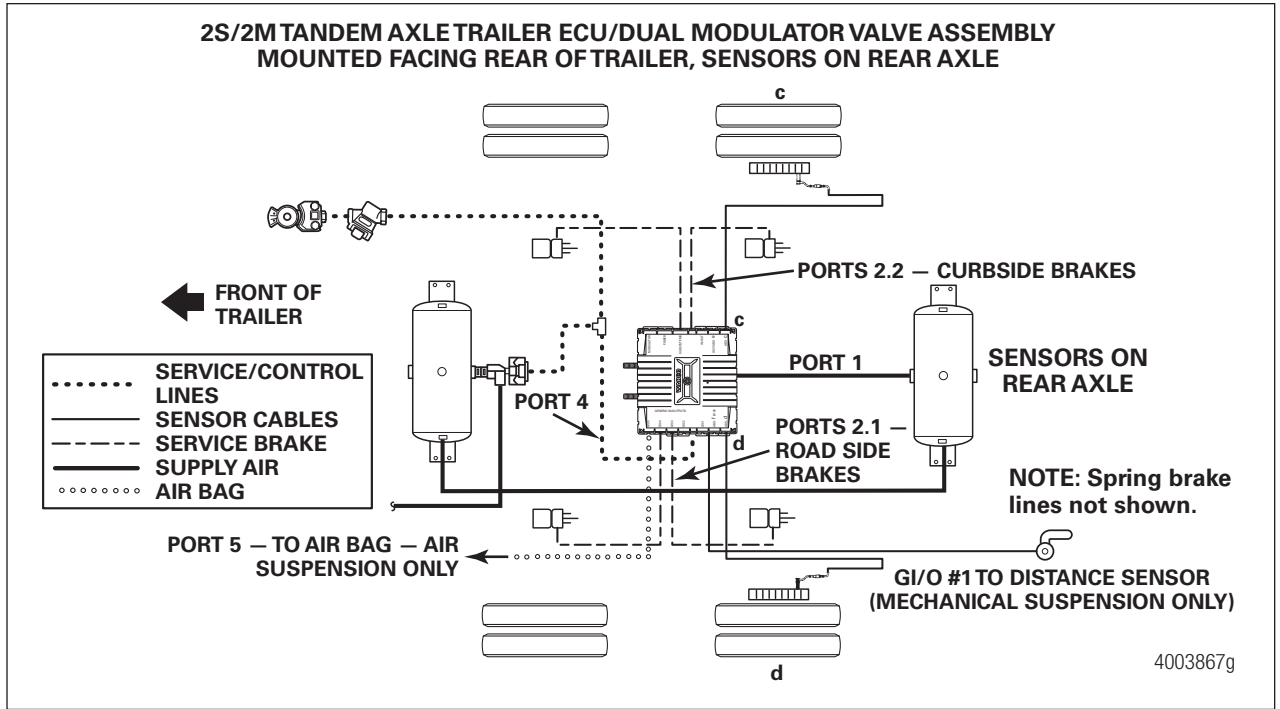
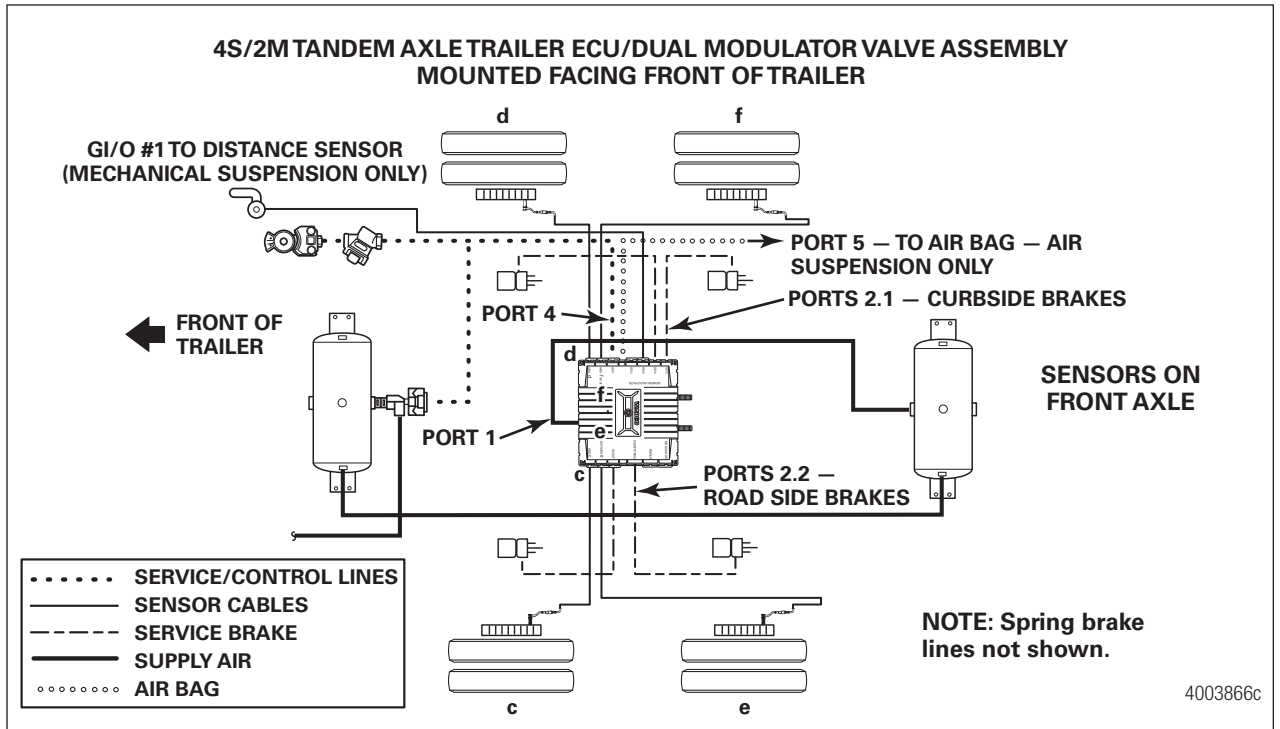

Fig. 6.5



# System Configurations

Fig. 6.6

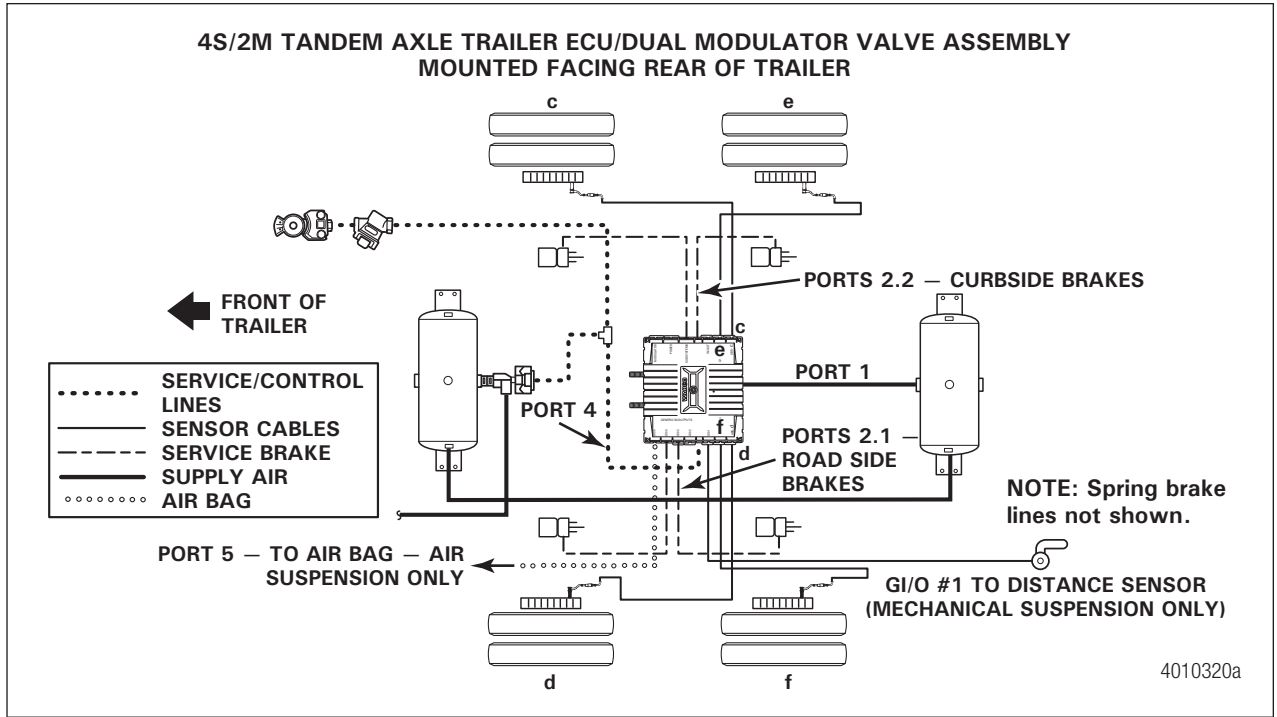
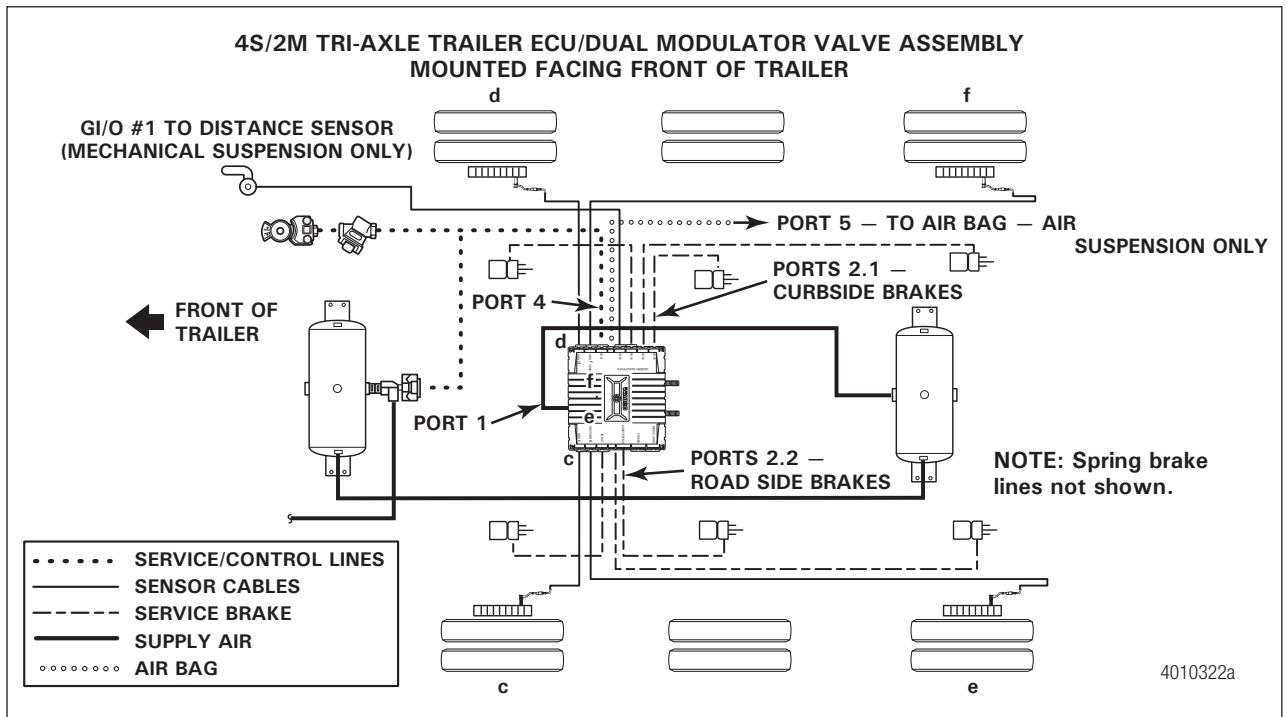
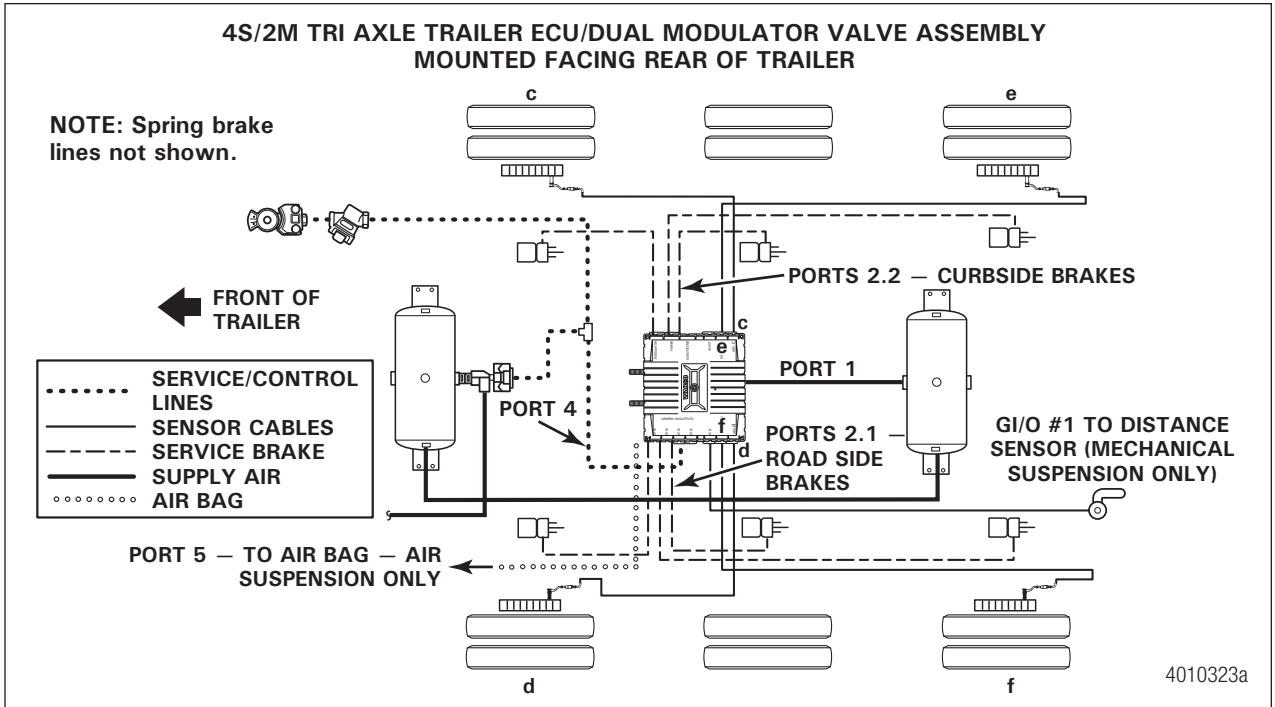

Fig. 6.7



# System Configurations

Fig. 6.8







# System Configurations

Fig. 6.10

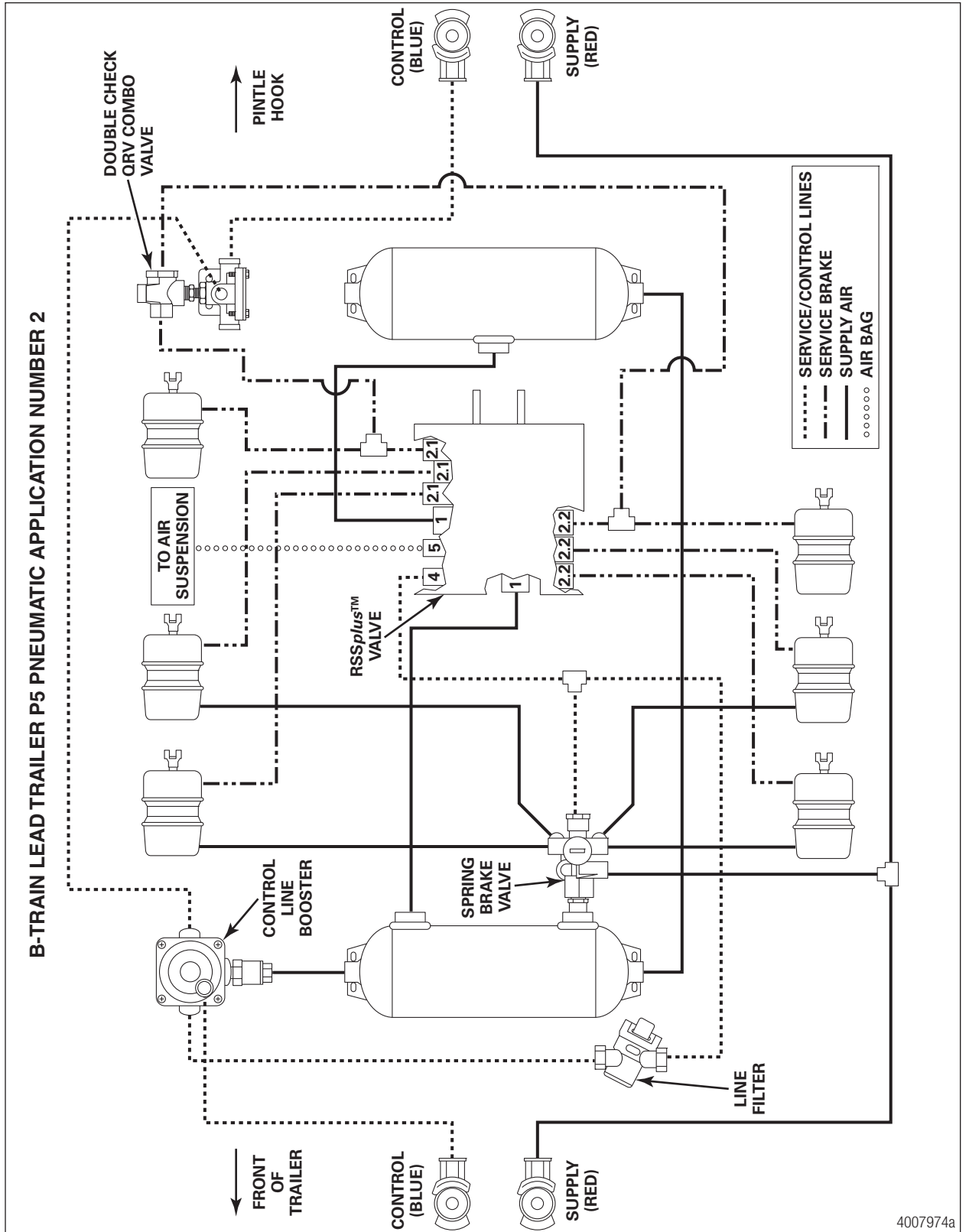

# System Configurations

Fig. 6.11

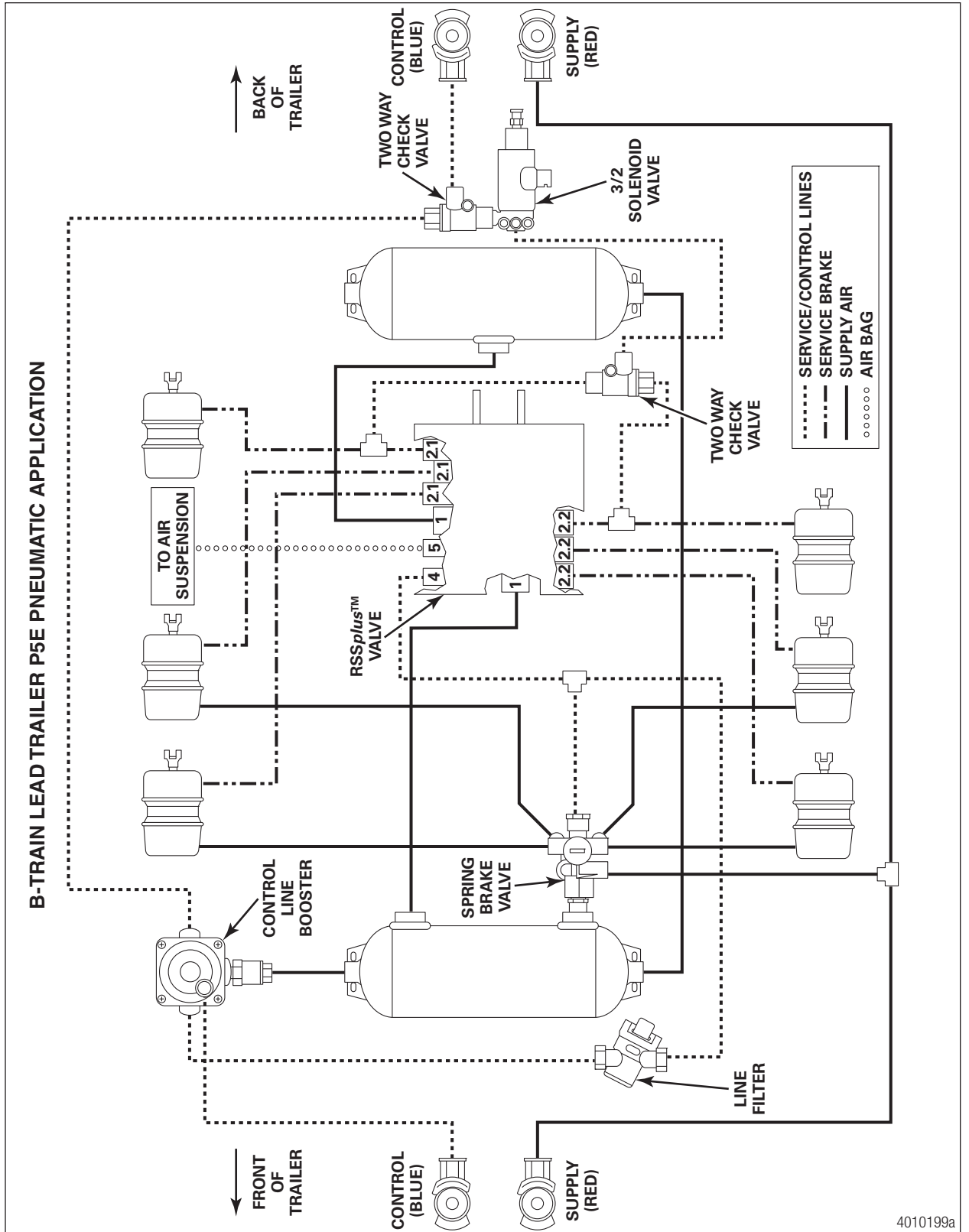

# System Configurations

## 6.2 Multiple Trailer Applications

Specific multiple trailer applications require additional plumbing and TOOLBOX™ Software configuration. Not all multiple trailer configurations have been approved. Contact WABCO prior to installation for guidance on multiple trailer configurations.

### 6.2.1 P5E

The Roll Stability System can be configured on B-Train trailers through the use of the patented WABCO P5E pneumatic application. The P5E system ensures that uniform braking occurs on both lead and pup trailers at the same time, similar to standard braking. The RSS*plus*™ valve and the P5E are required on the lead trailer of a B-Train, and it is recommended that an RSS*plus*™ valve be installed on the pup trailer as well. Additional valves are required as illustrated in Figure 6.11.

The ATC - Generic I/O Cable, part number 449 443 030 0, is connected to the GIO 3 port on the RSS+ ECU and on the electronics connector of the 3/2 Solenoid Valve, part number 472 170 997 0. The air system plumbing diagram for integrating the 3/2 Solenoid Valve and the Two Way Check Valves, part number 934 099 003 0, are illustrated in Figure 6.11.

Once the hardware has been installed, TOOLBOX™ Software parameters must be configured to activate the P5E system. When programming the ECU, ensure that "Level 2 RSS Activation Output (GIO 3)" is selected. Figure 6.12. Refer to Section 10 for setting the vehicle parameters.

Fig. 6.12

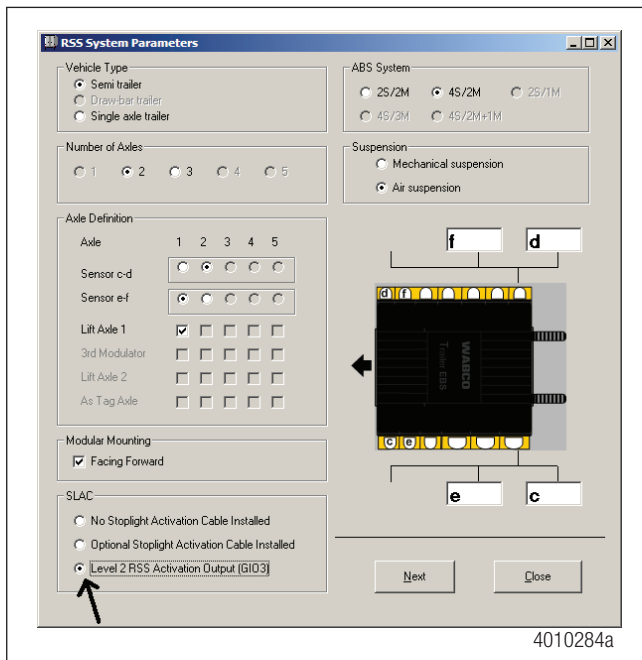

# System Configurations

After the P5E has been installed and the parameters have been saved to the ECU, the End of Line system sign-off must be performed. Refer to Section 9 for End of Line testing. Once the End of Line testing is complete and the P5E is ready for testing, proceed to the Tests pull-down menu and select Level 2 Function. Figure 6.13.

Fig. 6.13

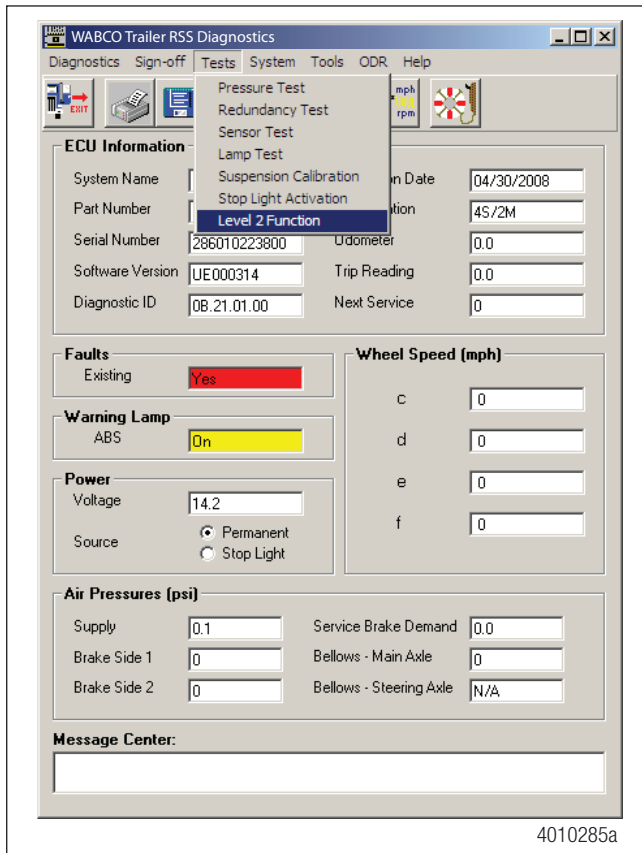

Press the Start button. Figure 6.14.

Fig. 6.14

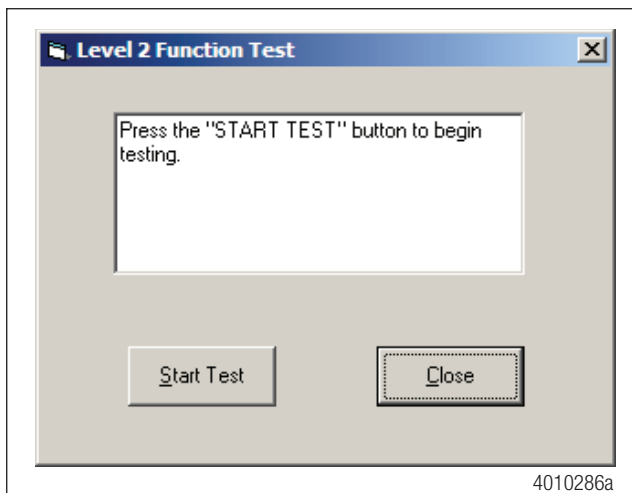

## System Configurations

During the sign-off procedure, this message will appear asking the technician to monitor the pressure gauge at the rear gladhand to confirm the RSS system is applying 50 psi (3.45 bar). This test validates that the pneumatic and electrical connections are correct. Figure 6.15.

Fig. 6.15

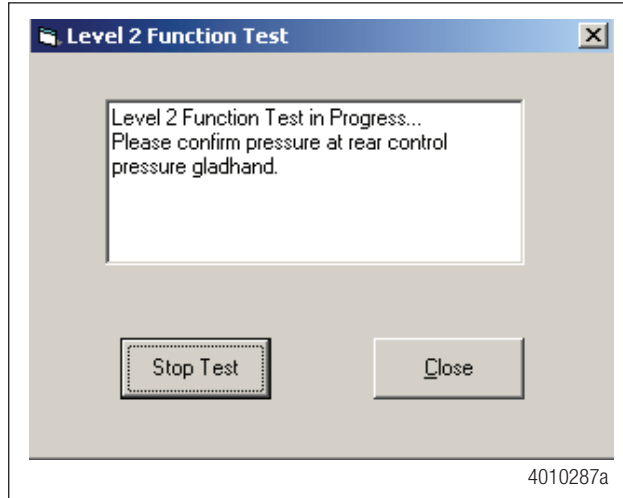

Once confirmed that the rear gladhand is maintaining 50 psi (3.45 bar), click the Close button. If  $50 \text{ psi} \pm 5 \text{ psi}$  ( $3.45 \pm 0.345 \text{ bar}$ ) is not present, click the Stop Test button, exit the Level 2 test and make the appropriate repairs.

### 6.6.2 P5

In certain older multiple trailer applications such as the lead trailer in a B-Train application, additional plumbing was added to the standard air system. The P5 plumbing configuration is similar to the P5E, but is used in older applications without the benefit of the electronic control. There are no additional TOOLBOX™ Software parameters required for the P5 configuration. However, note that a Quick Release Valve (such as the Sealco QRV part number 320100) is used in place of the P5E's 3/2 Solenoid Valve for P5 application number 1 (Figure 6.9). A Double Check QRV Combo Valve, part number 934 099 010 0, replaces the 3/2 Solenoid Valve in the P5 application number 2 (Figure 6.10).

# System Configurations

## 6.3 Wiring Diagrams

### 6.3.1 Power Cable

The following illustration shows the RSS2M power cable. Figure 6.16.

Fig. 6.16

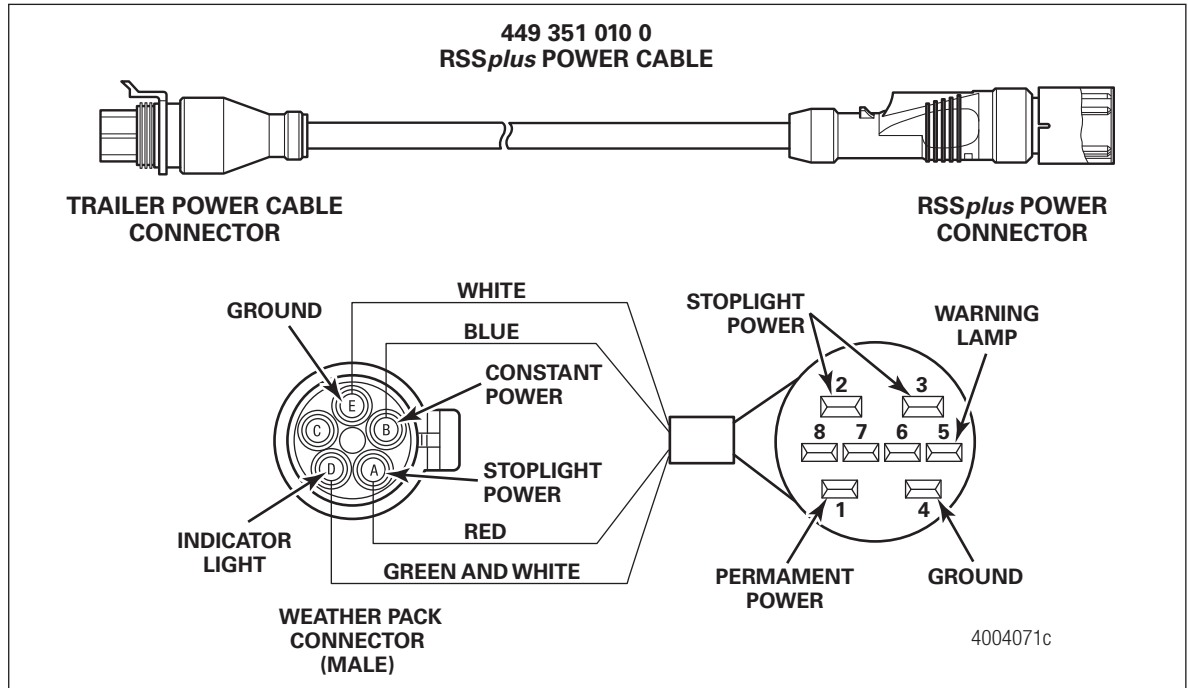

### 6.3.2 Lift Axle

A 4S/2M configuration may be configured with a lift axle on either axle.

- Sensors E and F are installed on the sensed, liftable axle.
- The sensed, liftable axle must be specified in the ECU parameters. Refer to the parameter entry guidelines in Section 10.

# Diagnostics

## 7 Diagnostics

Observe the following hazard alert messages when performing diagnostics.

### WARNING

To prevent serious eye injury, always wear safe eye protection when you perform vehicle maintenance or service.

### WARNING

The ABS is an electrical system. When you work on the ABS, take the same precautions that you must take with any electrical system to avoid serious personal injury. As with any electrical system, the danger of electrical shock or sparks exists that can ignite flammable substances. You must always disconnect the battery ground cable before working on the electrical system.

## 7.1 Diagnostoc Methods

There are two methods used to get fault information from the ECU:

- TOOLBOX™ Software
- Blink code diagnostics

TOOLBOX™ Software requires the PLC/J1708 adapter.

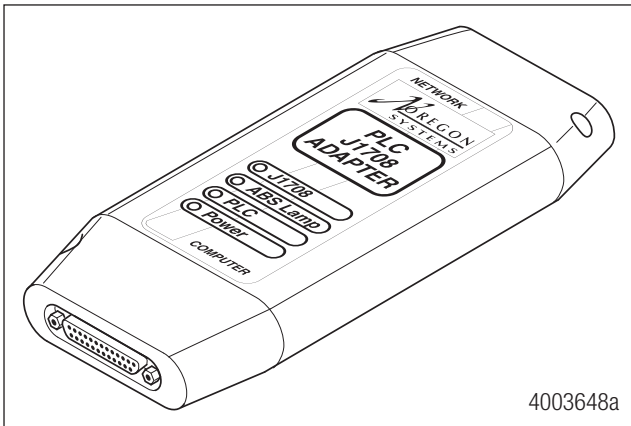

Available from Noregon Systems, 336-768-4337

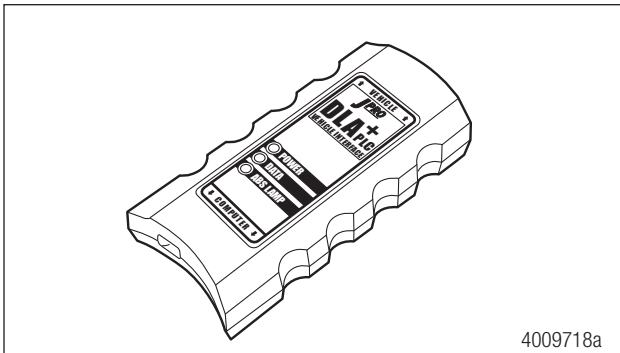

Available from [jprofleetproducts.com](http://jprofleetproducts.com), kit number 12204



# Diagnostics

## 7.2 Important PLC Information for Blink Code Diagnostics

Blink Code 17 indicates a PLC failure. If PLC does not seem to be operating correctly, but there is no Blink Code 17, the ECU is functioning correctly and does not need to be replaced; however, there could be a problem in the trailer's wiring harness. Check the wiring system and make the necessary repairs. If the problem persists, contact the WABCO Customer Care Center at 855-228-3203 for assistance.

## 7.3 TOOLBOX™ Software

TOOLBOX™ Software is a PC-based diagnostics program that can display wheel speed data, test individual components, verify installation wiring and is required to perform a sign-off for the *RSSplus*™ installation.

WABCO TOOLBOX™ Software, Version 12.2 (or higher) supports *RSSplus*™ with PLC and runs on Windows 7, 8, and 10. TOOLBOX™ Software is available for purchase via download 24 hours a day, seven days a week on <https://wabco.snacon.com/>.

TOOLBOX™ Software has the following functions.

- Supports *RSSplus*™ with PLC and Enhanced Easy-Stop™ ABS
- Displays both constant and changing information from the ECU being tested.
- Displays both active and stored system faults, as well as the appropriate repair instructions.
- Activates system components to verify:
  - System integrity
  - Correct component operation
  - Installation wiring



A J1587/J1708 to RS232 or PLC to J1708 interface is required to run this software.

## 7.4 Blink Code Diagnostics

The WABCO *RSSplus*™ Trailer ABS ECU detects any electrical fault in the trailer ABS. Each of the faults has a code. When a fault occurs, the ECU stores the code for that fault in the memory.

There are two kinds of faults: active and stored. Active faults are those currently existing in the system, such as a broken wire. Active faults can be diagnosed through blink codes or TOOLBOX™ Software. Stored faults are faults that have occurred but do not presently exist. Active faults can be cleared only after repairs are completed. Stored faults can only be diagnosed with TOOLBOX™ Software.

The ECU signals a malfunction by lighting both the internal and external indicator lamp when a fault exists. The external ABS indicator lamp is usually mounted on the left rear of the trailer, near the rear wheels. Blink codes are activated through Ignition Power Activation.

# Diagnostics

## 7.4.1 Ignition Power Activation

Ignition Power Activation is the process of using the vehicle's ignition switch (or interrupting the power on the blue wire by some other means) to display blink codes on the trailer ABS indicator lamp located on the side of the trailer. This method is for constant power vehicles only.



For ignition power activation, power is provided by the ignition switch.

To obtain blink codes using ignition power activation, perform the following procedure:

1. Turn the ignition switch on for no longer than five seconds. The ABS indicator lamp will be on.
2. Turn the ignition switch off. The ABS indicator lamp will go out.
3. Turn the ignition switch on. The ABS indicator lamp will then come on, then go out.
4. The blink code error will be displayed three times by the ABS indicator lamp on the trailer.

Blink Code Counts	Component Name
0	No failure
3	Sensor failure c
4	Sensor failure d
5	Sensor failure e
6	Sensor failure f
7	External modulator failure
9	Internal modulator failure H2
10	Internal modulator failure H1
11	No speed failure
12	Control pressure failure
13	Supply pressure failure
14	Power supply failure
15	ECU internal failure*
16	SAE J 1708 failure
17	PLC failure
18	Generic IO failure
19	Load sensing failure
20	Roll stability system failure

\*This error code will also appear on newly installed ECUs that have not been put into service with TOOLBOX™ Software End-of-Line test.

## 7.4.2 Internal Power-up Check

Whenever the trailer is initially powered up, the ABS light should come on for three seconds and the valves should click during self-tests. If the ABS light comes on again during the same ignition cycle, it would indicate an issue. If the valves do not click during the self-test, power and ground checks need to be performed at the ECU power connector. Also in this case, ensure all sensor cables are seated correctly at the ECU.

# Diagnostics

## 7.4.3 Power and Ground Checks

If the valve is not self-testing (no clicking from the valve), perform the following power and ground checks at the ABS ECU power connector shown in Figure 6.16.

1. Check the power cable connector at the ECU and verify that the lock tab is there and the connector is secure.
2. Disconnect the cable from the ECU and check for any signs of moisture, corrosion, spread or damaged pins.
3. Check with the power on voltage from pin 1 (constant power) to chassis ground for 9 to 14 volts.
  - If power shows between 9 to 14 volts, go to step 4.
  - If power is less or more than 9 to 14 volts, check the wiring for damage and review with the OEM.
4. With power on, check voltage from pins 2 and 3 (stop light power) to chassis ground with the brake pedal depressed to chassis ground for 9 to 14 volts.
  - If power shows between 9 to 14 volts, go to step 5.
  - If power is less or more than 9 to 14 volts, check the wiring for damage and review with the OEM.
5. With power off, check the resistance from pin 4 on the ECU power connector to chassis ground for less than 10 ohm.
  - If the resistance is less than 10 ohm, go to step 6.
  - If the resistance is higher than 10 ohm, check wiring for damage and review with the OEM.
6. With the power on, check constant power circuit. Perform a load lamp test across pins 1 to 4 and verify a bright light.
  - If the light is bright, go to step 8.
  - If the light does not light up brightly, diagnose and review the wiring with the OEM.
7. With the power on, check the stoplight circuit. Perform a load lamp test across pins 2 to 4 with the brakes applied and verify a bright light
  - If the light is bright, go to step 8.
  - If the light does not light up brightly, diagnose and review the wiring with the OEM.
8. If no problems are found with the harness, checks may indicate the ECU/valve assembly has failed.

## 7.5 Computer Diagnostics including TailGUARD

### 7.5.1 TOOLBOX™ Software

TOOLBOX™ Software is a PC-based diagnostics program that can display wheel speed data, test individual components, verify installation wiring and is required to perform a sign-off for the RSS*plus*™ installation.

# Diagnostics

WABCO TOOLBOX™ Software, Version 12.2 (or higher) supports RSS*plus*™ with PLC and runs on Windows 7. TOOLBOX™ Software is available for purchase via download 24 hours a day, seven days a week on <https://wabco.snapon.com/>.

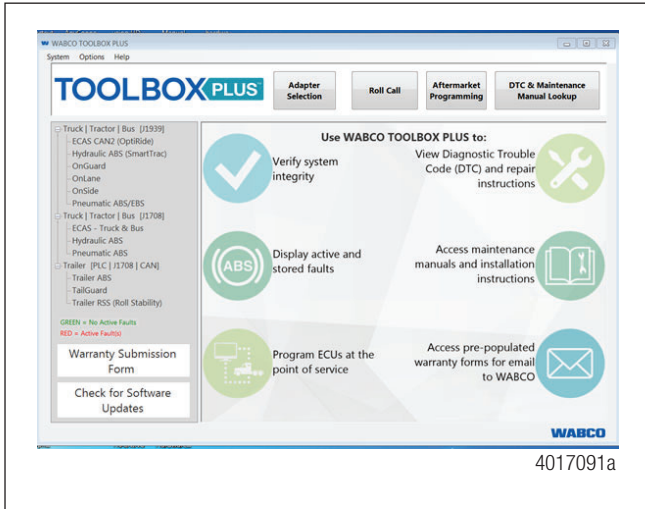

## 7.5.2 PLC/J 1708 Adapter

- Simulates the tractor ABS lamp, ensuring that the trailer ABS is capable of "lighting the light."
- Simulates the trailer ABS lamp, ensuring that the tractor is capable of "lighting the light."
- Use as a tractor/trailer tester to ensure that PLC is functioning correctly.

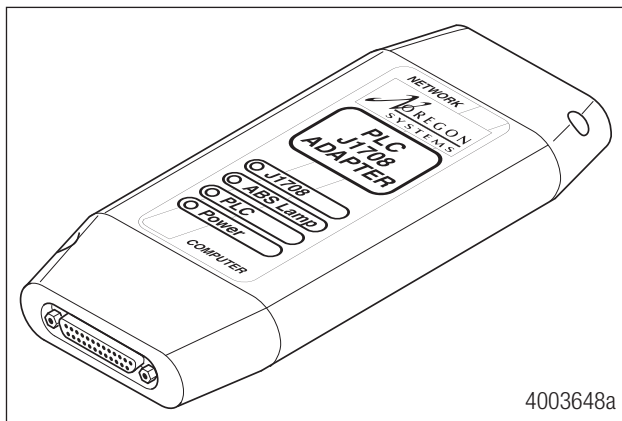

Available from Noregon Systems, 336-768-4337.

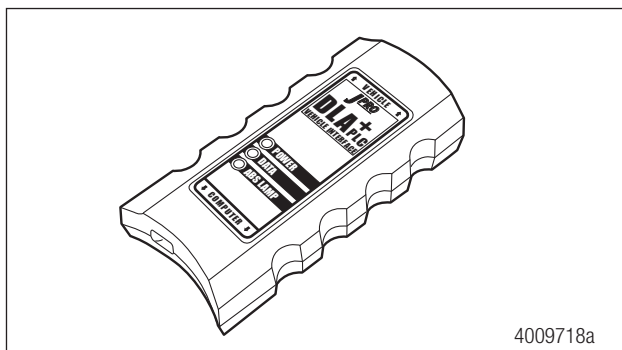

Available from [jprofleetproducts.com](http://jprofleetproducts.com), kit number 12204

# Diagnostics

## Main Screen

This screen provides icon and pull-down menu task selections. Select the *RSSplus™* icon to enter the Roll Stability Software.

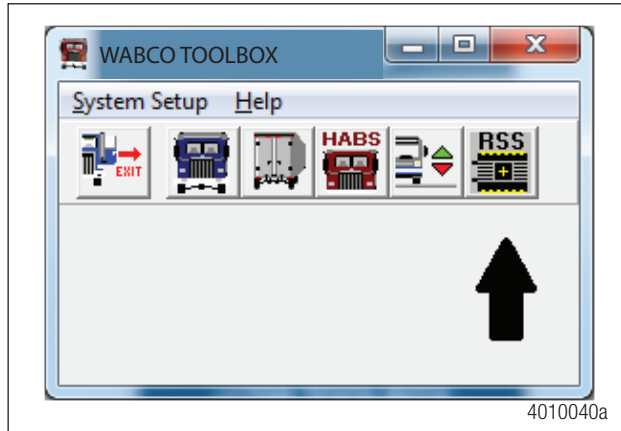

1. From the main screen of the WABCO trailer EBS diagnostics software, select Diagnostics from the top menu bar.

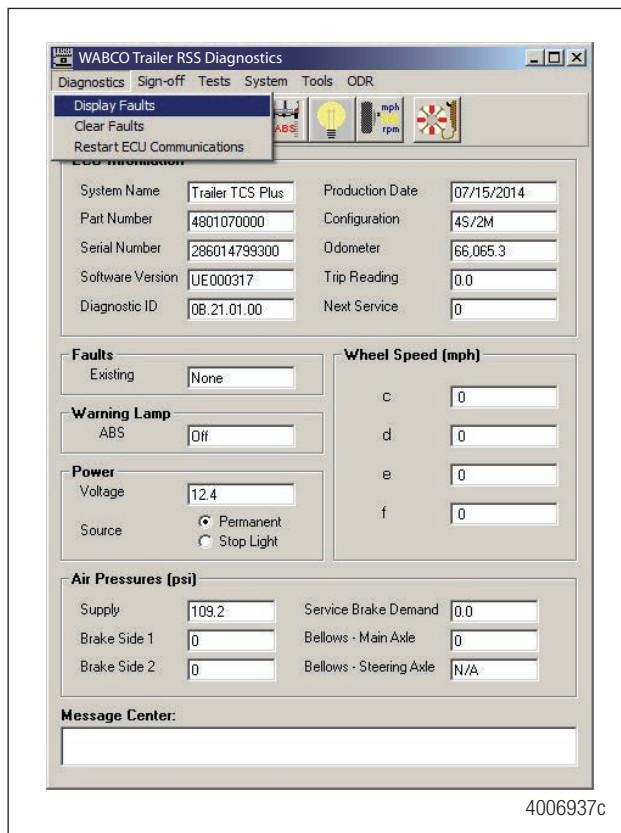

# Diagnostics

2. Select Display Faults from the pull-down menu. All active and stored faults are displayed.

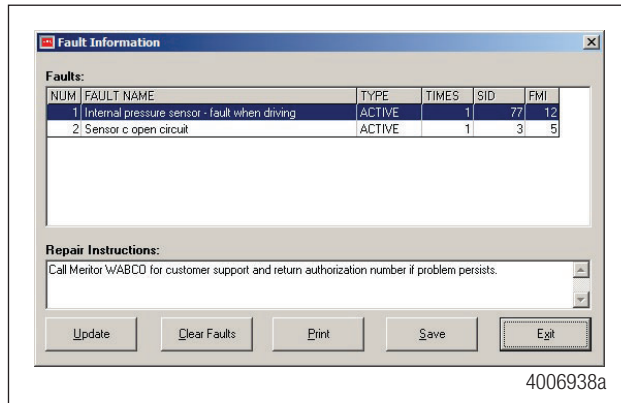

3. Repair active faults and take corrective action on stored faults. Once repaired, faults may be cleared by using the Clear Faults button.

## 7.5.3 RSSplus Diagnostic Codes

Using TOOLBOX™ Software, diagnostic codes are displayed on the Fault Information screen. Diagnostic codes by SID/FMI are found in the following tables.

SID	FMI	Suspect Component and Location	Fault Description (FMI)	Cause	Repair Information
3	1	Wheel Sensor (c)	Sensor signal is too low.	Sensor air gap is too large; sensor output voltage is too low but is high enough to be read by ECU.	<ul style="list-style-type: none"> <li>• Adjust wheel sensor to touch tone ring.</li> <li>• Check condition of ABS sensor head.</li> <li>• Check for loose wheel bearings or excessive hub runout.</li> <li>• Check mounting of ABS tone ring and condition of teeth.</li> <li>• Check condition and retention of ABS sensor spring clip.</li> <li>• Check ABS sensor cable routing and clipping.</li> <li>• Turn the wheel at half a revolution per second and verify 0.2 AC volt sensor output voltage.</li> </ul>
3	2	Wheel Sensor (c)	Sensor data is irregular or incorrect.	ECU has detected speed difference between axles (c-d) and (e-f).	<ul style="list-style-type: none"> <li>• Check for tire size mismatch.</li> <li>• Check for correct number of tone ring teeth.</li> </ul>
3	3	Wheel Sensor (c)	Over-voltage or short to supply voltage.	Continuity between the sensor connection and battery voltage (short circuit) is detected.	<ul style="list-style-type: none"> <li>• Verify 900-2000 ohms resistance through sensor circuit.</li> <li>• Verify no DC voltage through sensor circuit Key ON.</li> <li>• Check for corroded or damaged wiring between the ECU and the ABS wheel speed sensor.</li> <li>• Swap sensor in question with the adjacent sensor at the ECU. If the fault code location changes, test the sensor extension cable for shorts and opens. If the extension cable tests correctly, replace the sensor. If the fault code remains at the same location, replace the ECU.</li> </ul>
3	4	Wheel Sensor (c)	Under-voltage or short to ground.	Continuity between the sensor connection and ground (short circuit) is detected.	<ul style="list-style-type: none"> <li>• Verify 900-2000 ohms resistance through sensor circuit.</li> <li>• Check for continuity between the ABS sensor connection and ground.</li> <li>• Check for corroded or damaged wiring between the ECU and the ABS wheel speed sensor.</li> <li>• Swap sensor in question with the adjacent sensor at the ECU. If the fault code location changes, test the sensor extension cable for shorts and opens. If the extension cable tests correctly, replace the sensor. If the fault code remains at the same location, replace the ECU.</li> </ul>
3	5	Wheel Sensor (c)	Sensor signal interrupted.	An open circuit has been detected, i.e. ECU detects a disconnected wheel speed sensor.	<ul style="list-style-type: none"> <li>• Check sensor, sensor cable and connectors to verify no loose or damaged connection.</li> <li>• Verify 900-2000 ohms resistance through sensor circuit.</li> <li>• Check for corroded or damaged wiring between the ECU and the ABS wheel speed sensor.</li> <li>• Check for corrosion or discoloration at ECU sensor pins and/or connector.</li> <li>• Visually inspect sensor extension female connector to ensure it is not out of round or spread resulting in intermittent contact with the ECU sensor pins.</li> <li>• Swap sensor in question with the adjacent sensor at the ECU. If the fault code location changes, test the sensor extension cable for shorts and opens. If the extension cable tests correctly, replace the sensor. If the fault code remains at the same location, replace the ECU.</li> </ul>

SID	FMI	Suspect Component and Location	Fault Description (FMI)	Cause	Repair Information
3	6	Wheel Sensor (c)	High current or circuit grounded.	Continuity interruption between the sensor connections (short circuit) has been detected.	<ul style="list-style-type: none"> <li>• Check sensor, sensor cable and connectors to verify no loose or damaged connection.</li> <li>• Check for corroded or damaged wiring between the ECU and the ABS wheel speed sensor.</li> <li>• Check for corrosion or discoloration at ECU sensor pins and/or connector.</li> <li>• Visually inspect sensor extension female connector to ensure it is not out of round or spread resulting in intermittent contact with the ECU sensor pins.</li> <li>• Verify 900-2000 ohms resistance through sensor circuit.</li> <li>• Swap sensor in question with the adjacent sensor at the ECU. If the fault code location changes, test the sensor extension cable for shorts and opens. If the extension cable tests correctly, replace the sensor. If the fault code remains at the same location, replace the ECU.</li> </ul>
3	7	Wheel Sensor (c)	Tone ring damaged.	Wheel speed signal drops out periodically at speeds higher than 6 mph.	<ul style="list-style-type: none"> <li>• Check for damaged or missing teeth on tone ring.</li> <li>• Verify tone ring is not corroded or contaminated.</li> <li>• Check for loose wheel bearings or excessive hub runout.</li> <li>• Swap sensor in question with the adjacent sensor at the ECU. If the fault code location changes, test the sensor extension cable for shorts and opens. If the extension cable tests correctly, replace the sensor. If the fault code remains at the same location, replace the ECU.</li> </ul>
3	8	Wheel Sensor (c)	Excessive slip.	Wheel slip over 16 seconds continuously has been detected.	<ul style="list-style-type: none"> <li>• Adjust wheel sensor to touch tone ring.</li> <li>• Check sensor gap.</li> <li>• Check for loose wheel bearings or excessive hub runout.</li> </ul>
3	10	Wheel Sensor (c)	Sensor signal is erratic.	Wheel speed difference.	<ul style="list-style-type: none"> <li>• Check that tire size and number of teeth are correct.</li> <li>• Adjust wheel speed sensor until it touches the tone ring.</li> <li>• Check for loose wheel bearings or excessive hub runout.</li> <li>• Check sensor wiring and connectors for intermittent contact.</li> <li>• Check condition of ABS sensor head.</li> <li>• Check mounting of tone ring and condition of teeth.</li> <li>• Check condition and retention of ABS sensor spring clip.</li> <li>• Check ABS sensor cable routing and clipping.</li> <li>• Check for corroded or damaged wiring between the ECU and the ABS wheel speed sensor.</li> <li>• Turn the wheel at half a revolution per second and verify 0.2 AC volt sensor output voltage.</li> </ul>



SID	FMI	Suspect Component and Location	Fault Description (FMI)	Cause	Repair Information
3	11	Wheel Sensor (c)	Abnormal speed (chatter).	Brake drag or chatter has been detected. Abnormal vibrations detected which affect sensor signal.	<ul style="list-style-type: none"> <li>• Check for loose wheel bearings or excessive hub runout.</li> <li>• Check if brake at this location is operating correctly, i.e., potentially dragging.</li> <li>• Check sensor wiring and connectors for intermittent contact.</li> <li>• Verify 900-2000 ohms resistance through sensor circuit.</li> <li>• Check mounting of tone ring and condition of teeth.</li> <li>• Check condition and retention of ABS sensor spring clip as well as the mounting block.</li> <li>• Check for corroded or damaged wiring between the ECU and the ABS wheel speed sensor.</li> <li>• Turn the wheel at half a revolution per second and verify 0.2 AC volt sensor output voltage.</li> </ul>
3	12	Wheel Sensor (c)	Software interrupt failure.	A non-plausible sensor frequency has been measured.	<ul style="list-style-type: none"> <li>• Check sensor wiring and connectors for intermittent contact.</li> <li>• Check if brake at this location is operating correctly, i.e., potentially dragging.</li> <li>• Check for corroded or damaged wiring between the ECU and the ABS wheel speed sensor.</li> </ul>
3	13	Wheel Sensor (c)	Signal characteristic curve error.	Tone ring signal irregular.	<ul style="list-style-type: none"> <li>• Check for loose wheel bearings or excessive hub runout.</li> <li>• Check sensor wiring and connectors for intermittent contact.</li> <li>• Check mounting of tone ring and condition of teeth.</li> <li>• If tone ring and sensor block are not aligned correctly, oscillation may occur. Small dimensional deviations can result in this failure code. Issue occurs shortly after going into service and after driving.</li> <li>• Check condition and retention of ABS sensor spring clip as well as the mounting block.</li> <li>• Check for corroded or damaged wiring between the ECU and the ABS wheel speed sensor.</li> <li>• Turn the wheel at half a revolution per second and verify 0.2 AC volt sensor output voltage.</li> </ul>
4	1	Wheel Sensor (d)	Sensor signal is too low.	Sensor air gap is too large; sensor output voltage is too low but is high enough to be read by ECU.	<ul style="list-style-type: none"> <li>• Adjust wheel sensor to touch tone ring.</li> <li>• Check condition of ABS sensor head.</li> <li>• Check for loose wheel bearings or excessive hub runout.</li> <li>• Check mounting of ABS tone ring and condition of teeth.</li> <li>• Check condition and retention of ABS sensor spring clip.</li> <li>• Check ABS sensor cable routing and clipping.</li> <li>• Turn the wheel at half a revolution per second and verify 0.2 AC volt sensor output voltage.</li> </ul>
4	2	Wheel Sensor (d)	Sensor data is irregular or incorrect.	ECU has detected speed difference between axles (c-d) and (e-f).	<ul style="list-style-type: none"> <li>• Check for tire size mismatch.</li> <li>• Check for correct number of tone ring teeth.</li> </ul>

SID	FMI	Suspect Component and Location	Fault Description (FMI)	Cause	Repair Information
4	3	Wheel Sensor (d)	Over-voltage or short to supply voltage.	Continuity between the sensor connection and battery voltage (short circuit) is detected.	<ul style="list-style-type: none"> <li>• Verify 900-2000 ohms resistance through sensor circuit.</li> <li>• Verify no DC voltage through sensor circuit Key ON.</li> <li>• Check for corroded or damaged wiring between the ECU and the ABS wheel speed sensor.</li> </ul>
4	4	Wheel Sensor (d)	Under-voltage or short to ground.	Continuity between the sensor connection and ground (short circuit) is detected.	<ul style="list-style-type: none"> <li>• Verify 900-2000 ohms resistance through sensor circuit.</li> <li>• Check for continuity between the ABS sensor connection and ground.</li> <li>• Check for corroded or damaged wiring between the ECU and the ABS wheel speed sensor.</li> <li>• Swap sensor in question with the adjacent sensor at the ECU. If the fault code location changes, test the sensor extension cable for shorts and opens. If the extension cable tests correctly, replace the sensor. If the fault code remains at the same location, replace the ECU.</li> </ul>
4	5	Wheel Sensor (d)	Sensor signal interrupted.	An open circuit has been detected, i.e. ECU detects a disconnected wheel speed sensor.	<ul style="list-style-type: none"> <li>• Check sensor, sensor cable and connectors to verify no loose or damaged connection.</li> <li>• Verify 900-2000 ohms resistance through sensor circuit.</li> <li>• Check for corroded or damaged wiring between the ECU and the ABS wheel speed sensor.</li> <li>• Check for corrosion or discoloration at ECU sensor pins and/or connector.</li> <li>• Visually inspect sensor extension female connector to ensure it is not out of round or spread resulting in intermittent contact with the ECU sensor pins.</li> <li>• Swap sensor in question with the adjacent sensor at the ECU. If the fault code location changes, test the sensor extension cable for shorts and opens. If the extension cable tests correctly, replace the sensor. If the fault code remains at the same location, replace the ECU.</li> </ul>
4	6	Wheel Sensor (d)	High current or circuit grounded.	Continuity interruption between the sensor connections (short circuit) has been detected.	<ul style="list-style-type: none"> <li>• Check sensor, sensor cable and connectors to verify no loose or damaged connection.</li> <li>• Check for corroded or damaged wiring between the ECU and the ABS wheel speed sensor.</li> <li>• Check for corrosion or discoloration at ECU sensor pins and/or connector.</li> <li>• Visually inspect sensor extension female connector to ensure it is not out of round or spread resulting in intermittent contact with the ECU sensor pins.</li> <li>• Verify 900-2000 ohms resistance through sensor circuit.</li> <li>• Swap sensor in question with the adjacent sensor at the ECU. If the fault code location changes, test the sensor extension cable for shorts and opens. If the extension cable tests correctly, replace the sensor. If the fault code remains at the same location, replace the ECU.</li> </ul>

SID	FMI	Suspect Component and Location	Fault Description (FMI)	Cause	Repair Information
4	7	Wheel Sensor (d)	Tone ring damaged.	Wheel speed signal drops out periodically at speeds higher than 6 mph.	<ul style="list-style-type: none"> <li>• Check for damaged or missing teeth on tone ring.</li> <li>• Verify tone ring is not corroded or contaminated.</li> <li>• Check for loose wheel bearings or excessive hub runout.</li> <li>• Swap sensor in question with the adjacent sensor at the ECU. If the fault code location changes, test the sensor extension cable for shorts and opens. If the extension cable tests correctly, replace the sensor. If the fault code remains at the same location, replace the ECU.</li> </ul>
4	8	Wheel Sensor (d)	Excessive slip.	Wheel slip over 16 seconds continuously has been detected.	<ul style="list-style-type: none"> <li>• Adjust wheel sensor to touch tone ring.</li> <li>• Check sensor gap.</li> <li>• Check for loose wheel bearings or excessive hub runout.</li> </ul>
4	10	Wheel Sensor (d)	Sensor signal is erratic.	Wheel speed difference.	<ul style="list-style-type: none"> <li>• Check that tire size and number of teeth are correct.</li> <li>• Adjust wheel speed sensor until it touches the tone ring.</li> <li>• Check for loose wheel bearings or excessive hub runout.</li> <li>• Check sensor wiring and connectors for intermittent contact.</li> <li>• Check condition of ABS sensor head.</li> <li>• Check mounting of tone ring and condition of teeth.</li> <li>• Check condition and retention of ABS sensor spring clip.</li> <li>• Check ABS sensor cable routing and clipping.</li> <li>• Check for corroded or damaged wiring between the ECU and the ABS wheel speed sensor.</li> <li>• Turn the wheel at half a revolution per second and verify 0.2 AC volt sensor output voltage.</li> </ul>
4	11	Wheel Sensor (d)	Abnormal speed (chatter).	Brake drag or chatter has been detected. Abnormal vibrations detected which affect sensor signal.	<ul style="list-style-type: none"> <li>• Check for loose wheel bearings or excessive hub runout.</li> <li>• Check sensor wiring and connectors for intermittent contact.</li> <li>• Verify 900-2000 ohms resistance through sensor circuit.</li> <li>• Check mounting of tone ring and condition of teeth.</li> <li>• Check condition and retention of ABS sensor spring clip as well as the mounting block.</li> <li>• Check for corroded or damaged wiring between the ECU and the ABS wheel speed sensor.</li> <li>• Turn the wheel at half a revolution per second and verify 0.2 AC volt sensor output voltage.</li> </ul>
4	12	Wheel Sensor (d)	Software interrupt failure.	A non-plausible sensor frequency has been measured.	<ul style="list-style-type: none"> <li>• Check sensor wiring and connectors for intermittent contact.</li> <li>• Check if brake at this location is operating correctly, i.e., potentially dragging.</li> <li>• Check for corroded or damaged wiring between the ECU and the ABS wheel speed sensor.</li> </ul>

SID	FMI	Suspect Component and Location	Fault Description (FMI)	Cause	Repair Information
4	13	Wheel Sensor (d)	Signal characteristic curve error.	Tone ring signal irregular.	<ul style="list-style-type: none"> <li>• Check for loose wheel bearings or excessive hub runout.</li> <li>• Check sensor wiring and connectors for intermittent contact.</li> <li>• Check mounting of tone ring and condition of teeth.</li> <li>• If tone ring and sensor block are not aligned correctly, oscillation may occur. Small dimensional deviations can result in this failure code. Issue occurs shortly after going into service and after driving.</li> <li>• Check condition and retention of ABS sensor spring clip as well as the mounting block.</li> <li>• Check for corroded or damaged wiring between the ECU and the ABS wheel speed sensor.</li> <li>• Turn the wheel at half a revolution per second and verify 0.2 AC volt sensor output voltage.</li> </ul>
5	1	Wheel Sensor (e)	Sensor signal is too low.	Sensor air gap is too large; sensor output voltage is too low but is high enough to be read by ECU.	<ul style="list-style-type: none"> <li>• Adjust wheel sensor to touch tone ring.</li> <li>• Check condition of ABS sensor head.</li> <li>• Check for loose wheel bearings or excessive hub runout.</li> <li>• Check mounting of ABS tone ring and condition of teeth.</li> <li>• Check condition and retention of ABS sensor spring clip.</li> <li>• Check ABS sensor cable routing and clipping.</li> <li>• Turn the wheel at half a revolution per second and verify 0.2 AC volt sensor output voltage.</li> </ul>
5	2	Wheel Sensor (e)	Sensor data is irregular or incorrect.	ECU has detected speed difference between axles (c-d) and (e-f).	<ul style="list-style-type: none"> <li>• Check for tire size mismatch.</li> <li>• Check for correct number of tone ring teeth.</li> </ul>
5	3	Wheel Sensor (e)	Over-voltage or short to supply voltage.	Continuity between the sensor connection and battery voltage (short circuit) is detected.	<ul style="list-style-type: none"> <li>• Verify 900-2000 ohms resistance through sensor circuit.</li> <li>• Verify no DC voltage through sensor circuit Key ON.</li> <li>• Check for corroded or damaged wiring between the ECU and the ABS wheel speed sensor.</li> </ul>
5	4	Wheel Sensor (e)	Under-voltage or short to ground.	Continuity between the sensor connection and ground (short circuit) is detected.	<ul style="list-style-type: none"> <li>• Verify 900-2000 ohms resistance through sensor circuit.</li> <li>• Check for continuity between the ABS sensor connection and ground.</li> <li>• Check for corroded or damaged wiring between the ECU and the ABS wheel speed sensor.</li> <li>• Swap sensor in question with the adjacent sensor at the ECU. If the fault code location changes, test the sensor extension cable for shorts and opens. If the extension cable tests correctly, replace the sensor. If the fault code remains at the same location, replace the ECU.</li> </ul>

SID	FMI	Suspect Component and Location	Fault Description (FMI)	Cause	Repair Information
5	5	Wheel Sensor (e)	Sensor signal interrupted.	An open circuit has been detected, i.e. ECU detects a disconnected wheel speed sensor.	<ul style="list-style-type: none"> <li>• Check sensor, sensor cable and connectors to verify no loose or damaged connection.</li> <li>• Verify 900-2000 ohms resistance through sensor circuit.</li> <li>• Check for corroded or damaged wiring between the ECU and the ABS wheel speed sensor.</li> <li>• Check for corrosion or discoloration at ECU sensor pins and/or connector.</li> <li>• Visually inspect sensor extension female connector to ensure it is not out of round or spread resulting in intermittent contact with the ECU sensor pins.</li> <li>• Swap sensor in question with the adjacent sensor at the ECU. If the fault code location changes, test the sensor extension cable for shorts and opens. If the extension cable tests correctly, replace the sensor. If the fault code remains at the same location, replace the ECU.</li> </ul>
5	6	Wheel Sensor (e)	High current or circuit grounded.	Continuity interruption between the sensor connections (short circuit) has been detected.	<ul style="list-style-type: none"> <li>• Check sensor, sensor cable and connectors to verify no loose or damaged connection.</li> <li>• Check for corroded or damaged wiring between the ECU and the ABS wheel speed sensor.</li> <li>• Check for corrosion or discoloration at ECU sensor pins and/or connector.</li> <li>• Visually inspect sensor extension female connector to ensure it is not out of round or spread resulting in intermittent contact with the ECU sensor pins.</li> <li>• Verify 900-2000 ohms resistance through sensor circuit.</li> <li>• Swap sensor in question with the adjacent sensor at the ECU. If the fault code location changes, test the sensor extension cable for shorts and opens. If the extension cable tests correctly, replace the sensor. If the fault code remains at the same location, replace the ECU.</li> </ul>
5	7	Wheel Sensor (e)	Tone ring damaged.	Wheel speed signal drops out periodically at speeds higher than 6 mph.	<ul style="list-style-type: none"> <li>• Check for damaged or missing teeth on tone ring.</li> <li>• Verify tone ring is not corroded or contaminated.</li> <li>• Check for loose wheel bearings or excessive hub runout.</li> <li>• Swap sensor in question with adjacent sensor at the ECU. If the fault code stays in the same location, replace ECU. If the fault code changes locations, replace the suspect sensor.</li> </ul>
5	8	Wheel Sensor (e)	Excessive slip.	Wheel slip over 16 seconds continuously has been detected.	<ul style="list-style-type: none"> <li>• Adjust wheel sensor to touch tone ring.</li> <li>• Check sensor gap.</li> <li>• Check for loose wheel bearings or excessive hub runout.</li> </ul>

SID	FMI	Suspect Component and Location	Fault Description (FMI)	Cause	Repair Information
5	10	Wheel Sensor (e)	Sensor signal is erratic.	Wheel speed difference.	<ul style="list-style-type: none"> <li>• Check that tire size and number of teeth are correct.</li> <li>• Adjust wheel speed sensor until it touches the tone ring.</li> <li>• Check for loose wheel bearings or excessive hub runout.</li> <li>• Check sensor wiring and connectors for intermittent contact.</li> <li>• Check condition of ABS sensor head.</li> <li>• Check mounting of tone ring and condition of teeth.</li> <li>• Check condition and retention of ABS sensor spring clip.</li> <li>• Check ABS sensor cable routing and clipping.</li> <li>• Check for corroded or damaged wiring between the ECU and the ABS wheel speed sensor.</li> <li>• Turn the wheel at half a revolution per second and verify 0.2 AC volt sensor output voltage.</li> </ul>
5	11	Wheel Sensor (e)	Abnormal speed (chatter).	Brake drag or chatter has been detected. Abnormal vibrations detected which affect sensor signal.	<ul style="list-style-type: none"> <li>• Check for loose wheel bearings or excessive hub runout.</li> <li>• Check sensor wiring and connectors for intermittent contact.</li> <li>• Verify 900-2000 ohms resistance through sensor circuit.</li> <li>• Check mounting of tone ring and condition of teeth.</li> <li>• Check condition and retention of ABS sensor spring clip as well as the mounting block.</li> <li>• Check for corroded or damaged wiring between the ECU and the ABS wheel speed sensor.</li> <li>• Turn the wheel at half a revolution per second and verify 0.2 AC volt sensor output voltage.</li> </ul>
5	12	Wheel Sensor (e)	Software interrupt failure.	A non-plausible sensor frequency has been measured.	<ul style="list-style-type: none"> <li>• Check sensor wiring and connectors for intermittent contact.</li> <li>• Check if brake at this location is operating correctly, i.e., potentially dragging.</li> <li>• Check for corroded or damaged wiring between the ECU and the ABS wheel speed sensor.</li> </ul>
5	13	Wheel Sensor (e)	Signal characteristic curve error.	Tone ring signal irregular.	<ul style="list-style-type: none"> <li>• Check for loose wheel bearings or excessive hub runout.</li> <li>• Check sensor wiring and connectors for intermittent contact.</li> <li>• Check mounting of tone ring and condition of teeth.</li> <li>• If tone ring and sensor block are not aligned correctly, oscillation may occur. Small dimensional deviations can result in this failure code. Issue occurs shortly after going into service and after driving.</li> <li>• Check condition and retention of ABS sensor spring clip as well as the mounting block.</li> <li>• Check for corroded or damaged wiring between the ECU and the ABS wheel speed sensor.</li> <li>• Turn the wheel at half a revolution per second and verify 0.2 AC volt sensor output voltage.</li> </ul>

SID	FMI	Suspect Component and Location	Fault Description (FMI)	Cause	Repair Information
6	1	Wheel Sensor (f)	Sensor signal is too low.	Sensor air gap is too large; sensor output voltage is too low but is high enough to be read by ECU.	<ul style="list-style-type: none"> <li>Adjust wheel sensor to touch tone ring.</li> <li>Check condition of ABS sensor head.</li> <li>Check for loose wheel bearings or excessive hub runout.</li> <li>Check mounting of ABS tone ring and condition of teeth.</li> <li>Check condition and retention of ABS sensor spring clip.</li> <li>Check ABS sensor cable routing and clipping.</li> <li>Turn the wheel at half a revolution per second and verify 0.2 AC volt sensor output voltage.</li> </ul>
6	2	Wheel Sensor (f)	Sensor data is irregular or incorrect.	ECU has detected speed difference between axles (c-d) and (e-f).	<ul style="list-style-type: none"> <li>Check for tire size mismatch.</li> <li>Check for correct number of tone ring teeth.</li> </ul>
6	3	Wheel Sensor (f)	Over-voltage or short to supply voltage.	Continuity between the sensor connection and battery voltage (short circuit) is detected.	<ul style="list-style-type: none"> <li>Verify 900-2000 ohms resistance through sensor circuit.</li> <li>Verify no DC voltage through sensor circuit Key ON.</li> <li>Check for corroded or damaged wiring between the ECU and the ABS wheel speed sensor.</li> </ul>
6	4	Wheel Sensor (f)	Under-voltage or short to ground.	Continuity between the sensor connection and ground (short circuit) is detected.	<ul style="list-style-type: none"> <li>Verify 900-2000 ohms resistance through sensor circuit.</li> <li>Check for continuity between the ABS sensor connection and ground.</li> <li>Check for corroded or damaged wiring between the ECU and the ABS wheel speed sensor.</li> <li>Swap sensor in question with the adjacent sensor at the ECU. If the fault code location changes, test the sensor extension cable for shorts and opens. If the extension cable tests correctly, replace the sensor. If the fault code remains at the same location, replace the ECU.</li> </ul>
6	5	Wheel Sensor (f)	Sensor signal interrupted.	An open circuit has been detected, i.e. ECU detects a disconnected wheel speed sensor.	<ul style="list-style-type: none"> <li>Check sensor, sensor cable and connectors to verify no loose or damaged connection.</li> <li>Verify 900-2000 ohms resistance through sensor circuit.</li> <li>Check for corroded or damaged wiring between the ECU and the ABS wheel speed sensor.</li> <li>Check for corrosion or discoloration at ECU sensor pins and/or connector.</li> <li>Visually inspect sensor extension female connector to ensure it is not out of round or spread resulting in intermittent contact with the ECU sensor pins.</li> <li>Swap sensor in question with the adjacent sensor at the ECU. If the fault code location changes, test the sensor extension cable for shorts and opens. If the extension cable tests correctly, replace the sensor. If the fault code remains at the same location, replace the ECU.</li> </ul>



SID	FMI	Suspect Component and Location	Fault Description (FMI)	Cause	Repair Information
6	6	Wheel Sensor (f)	High current or circuit grounded.	Continuity interruption between the sensor connections (short circuit) has been detected.	<ul style="list-style-type: none"> <li>• Check sensor, sensor cable and connectors to verify no loose or damaged connection.</li> <li>• Check for corroded or damaged wiring between the ECU and the ABS wheel speed sensor.</li> <li>• Check for corrosion or discoloration at ECU sensor pins and/or connector.</li> <li>• Visually inspect sensor extension female connector to ensure it is not out of round or spread resulting in intermittent contact with the ECU sensor pins.</li> <li>• Verify 900-2000 ohms resistance through sensor circuit.</li> <li>• Swap sensor in question with the adjacent sensor at the ECU. If the fault code location changes, test the sensor extension cable for shorts and opens. If the extension cable tests correctly, replace the sensor. If the fault code remains at the same location, replace the ECU.</li> </ul>
6	7	Wheel Sensor (f)	Tone ring damaged.	Wheel speed signal drops out periodically at speeds higher than 6 mph.	<ul style="list-style-type: none"> <li>• Check for damaged or missing teeth on tone ring.</li> <li>• Verify tone ring is not corroded or contaminated.</li> <li>• Check for loose wheel bearings or excessive hub runout.</li> <li>• Swap sensor in question with adjacent sensor at the ECU. If the fault code stays in the same location, replace ECU. If the fault code changes locations, replace the suspect sensor.</li> </ul>
6	8	Wheel Sensor (f)	Excessive slip.	Wheel slip over 16 seconds continuously has been detected.	<ul style="list-style-type: none"> <li>• Adjust wheel sensor to touch tone ring.</li> <li>• Check sensor gap.</li> <li>• Check for loose wheel bearings or excessive hub runout.</li> </ul>
6	10	Wheel Sensor (f)	Sensor signal is erratic.	Wheel speed difference.	<ul style="list-style-type: none"> <li>• Check that tire size and number of teeth are correct.</li> <li>• Adjust wheel speed sensor until it touches the tone ring.</li> <li>• Check for loose wheel bearings or excessive hub runout.</li> <li>• Check sensor wiring and connectors for intermittent contact.</li> <li>• Check condition of ABS sensor head.</li> <li>• Check mounting of tone ring and condition of teeth.</li> <li>• Check condition and retention of ABS sensor spring clip.</li> <li>• Check ABS sensor cable routing and clipping.</li> <li>• Check for corroded or damaged wiring between the ECU and the ABS wheel speed sensor.</li> <li>• Turn the wheel at half a revolution per second and verify 0.2 AC volt sensor output voltage.</li> </ul>



SID	FMI	Suspect Component and Location	Fault Description (FMI)	Cause	Repair Information
6	11	Wheel Sensor (f)	Abnormal speed (chatter).	Brake drag or chatter has been detected. Abnormal vibrations detected which affect sensor signal.	<ul style="list-style-type: none"> <li>• Check for loose wheel bearings or excessive hub runout.</li> <li>• Check sensor wiring and connectors for intermittent contact.</li> <li>• Verify 900-2000 ohms resistance through sensor circuit.</li> <li>• Check mounting of tone ring and condition of teeth.</li> <li>• Check condition and retention of ABS sensor spring clip as well as the mounting block.</li> <li>• Check for corroded or damaged wiring between the ECU and the ABS wheel speed sensor.</li> <li>• Turn the wheel at half a revolution per second and verify 0.2 AC volt sensor output voltage.</li> </ul>
6	12	Wheel Sensor (f)	Software interrupt failure.	A non-plausible sensor frequency has been measured.	<ul style="list-style-type: none"> <li>• Check sensor wiring and connectors for intermittent contact.</li> <li>• Check if brake at this location is operating correctly, i.e., potentially dragging.</li> <li>• Check for corroded or damaged wiring between the ECU and the ABS wheel speed sensor.</li> </ul>
6	13	Wheel Sensor (f)	Signal characteristic curve error.	Tone ring signal irregular.	<ul style="list-style-type: none"> <li>• Check for loose wheel bearings or excessive hub runout.</li> <li>• Check sensor wiring and connectors for intermittent contact.</li> <li>• Check mounting of tone ring and condition of teeth.</li> <li>• If tone ring and sensor block are not aligned correctly, oscillation may occur. Small dimensional deviations can result in this failure code. Issue occurs shortly after going into service and after driving.</li> <li>• Check condition and retention of ABS sensor spring clip as well as the mounting block.</li> <li>• Check for corroded or damaged wiring between the ECU and the ABS wheel speed sensor.</li> <li>• Turn the wheel at half a revolution per second and verify 0.2 AC volt sensor output voltage.</li> </ul>
7	3	External ABS Modulator Valve	Over-voltage/short to supply voltage.	ABS ECU has detected an over-voltage/short to supply voltage condition on the external modulator valve.	<ul style="list-style-type: none"> <li>• Verify an external modulator is installed by checking to see if a cable is plugged in to the external modulator port of the RSS ECU.</li> <li>• Verify if no cable is attached, that the external modulator cap is sealed and there are no signs of moisture or corrosion on the pins of the RSS ECU.</li> <li>• If no external modulator valve is used and all previous checks pass, reconfigure the system to a 2S/2M or 4S/2M system depending on how many sensors are used through the WABCO TOOLBOX™ Software.</li> <li>• If equipped with an external modulator, verify resistance from the exhaust and inlet valve to ground is between 4 to 8 ohms through the whole circuit.</li> <li>• Verify there is no voltage on any of the pins of the external modulator valve cable to chassis ground.</li> </ul>

SID	FMI	Suspect Component and Location	Fault Description (FMI)	Cause	Repair Information
7	4	External ABS Modulator Valve	Under-voltage/short to ground.	ABS ECU has detected an under-voltage/short to ground condition on the external modulator valve.	<ul style="list-style-type: none"> <li>Verify an external modulator is installed by checking to see if a cable is plugged in to the external modulator port of the RSS ECU.</li> <li>Verify if no cable is attached that the external modulator cap is sealed and there are no signs of moisture or corrosion on the pins of the RSS ECU.</li> <li>If no external modulator valve is used and all previous checks pass, reconfigure the system to a 2S/2M or 4S/2M system depending on how many sensors are used through the WABCO TOOLBOX™ Software.</li> <li>If equipped with an external modulator, verify resistance from the exhaust and inlet valve to ground is between 4 to 8 ohms through the whole circuit.</li> <li>Verify there is no continuity on any of the pins of the external modulator valve cable to chassis ground.</li> </ul>
7	5	External ABS Modulator Valve	Open circuit.	ABS ECU has detected an open circuit on the external modulator valve.	<ul style="list-style-type: none"> <li>Verify an external modulator is installed by checking to see if a cable is plugged in to the external modulator port of the RSS ECU.</li> <li>Verify if no cable is attached that the external modulator cap is sealed and there are no signs of moisture or corrosion on the pins of the RSS ECU.</li> <li>If no external modulator valve is used and all previous checks pass, reconfigure the system to a 2S/2M or 4S/2M system depending on how many sensors are used through the WABCO TOOLBOX™ Software.</li> <li>If equipped with an external modulator, verify resistance from the exhaust and inlet valve to ground is between 4 to 8 ohms through the whole circuit.</li> <li>Verify there is no continuity on any of the pins of the external modulator valve cable to chassis ground.</li> </ul>
7	6	External ABS Modulator Valve	High current/short to ground.	ABS ECU has detected a high current/short to ground condition on the external modulator valve.	<ul style="list-style-type: none"> <li>Verify an external modulator is installed by checking to see if a cable is plugged in to the external modulator port of the RSS ECU.</li> <li>Verify if no cable is attached that the external modulator cap is sealed and there are no signs of moisture or corrosion on the pins of the RSS ECU.</li> <li>If no external modulator valve is used and all previous checks pass, reconfigure the system to a 2S/2M or 4S/2M system depending on how many sensors are used through the WABCO TOOLBOX™ Software.</li> <li>If equipped with an external modulator, verify resistance from the exhaust and inlet valve to ground is between 4 to 8 ohms through the whole circuit.</li> <li>Verify there is no continuity on any of the pins of the external modulator valve cable to chassis ground.</li> </ul>
9	3	ECU Internal Modulator (H2)	Over-voltage/short to supply voltage.	ECU has detected an over-voltage/short to supply voltage condition on the internal H2 modulator.	<ul style="list-style-type: none"> <li>Verify the RSS ECU power connector is seated correctly and has no signs of moisture or corrosion.</li> <li>Verify correct power, ground at the main RSS ECU power connector and load test the power and ground circuit.</li> </ul>
9	4	ECU Internal Modulator (H2)	Under-voltage/short to ground.	ECU has detected an under-voltage/short to ground condition on the internal H2 modulator.	<ul style="list-style-type: none"> <li>Verify the RSS ECU power connector is seated correctly and has no signs of moisture or corrosion.</li> <li>Verify correct power, ground at the main RSS ECU power connector and load test the power and ground circuit.</li> </ul>

SID	FMI	Suspect Component and Location	Fault Description (FMI)	Cause	Repair Information
9	5	ECU Internal Modulator (H2)	Open circuit.	ECU has detected an open circuit on the internal H2 modulator.	<ul style="list-style-type: none"> <li>Verify the RSS ECU power connector is seated correctly and has no signs of moisture or corrosion.</li> <li>Verify correct power, ground at the main RSS ECU power connector and load test the power and ground circuit.</li> </ul>
9	6	ECU Internal Modulator (H2)	High current/short to ground.	ECU has detected a high current/short to ground condition on the internal H2 modulator.	<ul style="list-style-type: none"> <li>Verify the RSS ECU power connector is seated correctly and has no signs of moisture or corrosion.</li> <li>Verify correct power, ground at the main RSS ECU power connector and load test the power and ground circuit.</li> </ul>
9	11	ECU Internal Modulator (H2)	Circuit failure.	ECU has detected a circuit failure on the internal H2 modulator.	<ul style="list-style-type: none"> <li>Verify the RSS ECU power connector is seated correctly and has no signs of moisture or corrosion.</li> <li>Verify correct power, ground at the main RSS ECU power connector and load test the power and ground circuit.</li> </ul>
10	3	ECU Internal Modulator (H1)	Over-voltage/short to supply voltage.	ECU has detected an over-voltage/short to supply voltage condition on the internal H1 modulator.	<ul style="list-style-type: none"> <li>Verify the RSS ECU power connector is seated correctly and has no signs of moisture or corrosion.</li> <li>Verify correct power, ground at the main RSS ECU power connector and load test the power and ground circuit.</li> </ul>
10	4	ECU Internal Modulator (H1)	Under-voltage/short to ground.	ECU has detected an under-voltage/short to ground condition on the internal H1 modulator.	<ul style="list-style-type: none"> <li>Verify the RSS ECU power connector is seated correctly and has no signs of moisture or corrosion.</li> <li>Verify correct power, ground at the main RSS ECU power connector and load test the power and ground circuit.</li> </ul>
10	5	ECU Internal Modulator (H1)	Open circuit.	ECU has detected an open circuit on the internal H1 modulator.	<ul style="list-style-type: none"> <li>Verify the RSS ECU power connector is seated correctly and has no signs of moisture or corrosion.</li> <li>Verify correct power, ground at the main RSS ECU power connector and load test the power and ground circuit.</li> </ul>
10	6	ECU Internal Modulator (H1)	High current/short to ground.	ECU has detected a high current/short to ground condition on the internal H1 modulator.	<ul style="list-style-type: none"> <li>Verify the RSS ECU power connector is seated correctly and has no signs of moisture or corrosion.</li> <li>Verify correct power, ground at the main RSS ECU power connector and load test the power and ground circuit.</li> </ul>
10	11	ECU Internal Modulator (H1)	Circuit failure.	ECU has detected a circuit failure on the internal H1 modulator.	<ul style="list-style-type: none"> <li>Verify the RSS ECU power connector is seated correctly and has no signs of moisture or corrosion.</li> <li>Verify correct power, ground at the main RSS ECU power connector and load test the power and ground circuit.</li> </ul>

SID	FMI	Suspect Component and Location	Fault Description (FMI)	Cause	Repair Information
58	3	External ABS Modulator Valve (redundancy)	Over-voltage/short to supply voltage.	ABS ECU has detected an over-voltage/short to supply voltage condition on the external modulator valve.	<ul style="list-style-type: none"> <li>Verify an external modulator is installed by checking to see if a cable is plugged in to the external modulator port of the RSS ECU.</li> <li>Verify if no cable is attached that the external modulator cap is sealed and there are no signs of moisture or corrosion on the pins of the RSS ECU.</li> <li>If no external modulator valve is used and all previous checks pass, reconfigure the system to a 2S/2M or 4S/2M system depending on how many sensors are used through the WABCO TOOLBOX™ Software.</li> <li>If equipped with an external modulator, verify resistance from the exhaust and inlet valve to ground is between 4 to 8 ohms through the whole circuit.</li> <li>Verify there is no continuity on any of the pins of the external modulator valve cable to chassis ground.</li> </ul>
58	4	External ABS Modulator Valve (redundancy)	Under-voltage/short to ground.	ABS ECU has detected an under-voltage/short to ground condition on the external modulator valve.	<ul style="list-style-type: none"> <li>Verify an external modulator is installed by checking to see if a cable is plugged in to the external modulator port of the RSS ECU.</li> <li>Verify if no cable is attached that the external modulator cap is sealed and there are no signs of moisture or corrosion on the pins of the RSS ECU.</li> <li>If no external modulator valve is used and all previous checks pass, reconfigure the system to a 2S/2M or 4S/2M system depending on how many sensors are used through the WABCO TOOLBOX™ Software.</li> <li>If equipped with an external modulator, verify resistance from the exhaust and inlet valve to ground is between 4 to 8 ohms through the whole circuit.</li> <li>Verify there is no continuity on any of the pins of the external modulator valve cable to chassis ground.</li> </ul>
58	5	External ABS Modulator Valve (redundancy)	Open circuit.	ABS ECU has detected an open circuit on the external modulator valve.	<ul style="list-style-type: none"> <li>Verify an external modulator is installed by checking to see if a cable is plugged in to the external modulator port of the RSS ECU.</li> <li>Verify if no cable is attached that the external modulator cap is sealed and there are no signs of moisture or corrosion on the pins of the RSS ECU.</li> <li>If no external modulator valve is used and all previous checks pass, reconfigure the system to a 2S/2M or 4S/2M system depending on how many sensors are used through the WABCO TOOLBOX™ Software.</li> <li>If equipped with an external modulator, verify resistance from the exhaust and inlet valve to ground is between 4 to 8 ohms through the whole circuit.</li> <li>Verify there is no continuity on any of the pins of the external modulator valve cable to chassis ground.</li> </ul>

SID	FMI	Suspect Component and Location	Fault Description (FMI)	Cause	Repair Information
58	6	External ABS Modulator Valve (redundancy)	High current/short to ground.	ABS ECU has detected a high current/short to ground condition on the external modulator valve.	<ul style="list-style-type: none"> <li>Verify an external modulator is installed by checking to see if a cable is plugged in to the external modulator port of the RSS ECU.</li> <li>Verify if no cable is attached that the external modulator cap is sealed and there are no signs of moisture or corrosion on the pins of the RSS ECU.</li> <li>If no external modulator valve is used and all previous checks pass, reconfigure the system to a 2S/2M or 4S/2M system depending on how many sensors are used through the WABCO TOOLBOX™ Software.</li> <li>If equipped with an external modulator, verify resistance from the exhaust and inlet valve to ground is between 4 to 8 ohms through the whole circuit.</li> <li>Verify there is no continuity on any of the pins of the external modulator valve cable to chassis ground.</li> </ul>
59	3	External ABS Modulator Valve (pressure sensor)	Over-voltage/short to supply voltage.	ABS ECU has detected an over-voltage/short to supply voltage condition on the external modulator valve.	<ul style="list-style-type: none"> <li>Verify an external modulator is installed by checking to see if a cable is plugged in to the external modulator port of the RSS ECU.</li> <li>Verify if no cable is attached that the external modulator cap is sealed and there are no signs of moisture or corrosion on the pins of the RSS ECU.</li> <li>If no external modulator valve is used and all previous checks pass, reconfigure the system to a 2S/2M or 4S/2M system depending on how many sensors are used through the WABCO TOOLBOX™ Software.</li> <li>If equipped with an external modulator, verify resistance from the exhaust and inlet valve to ground is between 4 to 8 ohms through the whole circuit.</li> <li>Verify there is no continuity on any of the pins of the external modulator valve cable to chassis ground.</li> </ul>
59	4	External ABS Modulator Valve (pressure sensor)	Under-voltage/short to ground.	ABS ECU has detected an under-voltage/short to ground condition on the external modulator valve.	<ul style="list-style-type: none"> <li>Verify an external modulator is installed by checking to see if a cable is plugged in to the external modulator port of the RSS ECU.</li> <li>Verify if no cable is attached that the external modulator cap is sealed and there are no signs of moisture or corrosion on the pins of the RSS ECU.</li> <li>If no external modulator valve is used and all previous checks pass, reconfigure the system to a 2S/2M or 4S/2M system depending on how many sensors are used through the WABCO TOOLBOX™ Software.</li> <li>If equipped with an external modulator, verify resistance from the exhaust and inlet valve to ground is between 4 to 8 ohms through the whole circuit.</li> <li>Verify there is no continuity on any of the pins of the external modulator valve cable to chassis ground.</li> </ul>
59	11	External ABS Modulator Valve (pressure sensor)	Valve failure.	ABS ECU has detected a failure of the external modulator valve or cabling.	<ul style="list-style-type: none"> <li>Verify an external modulator is installed by checking to see if a cable is plugged in to the external modulator port of the RSS ECU.</li> <li>Verify if no cable is attached that the external modulator cap is sealed and there are no signs of moisture or corrosion on the pins of the RSS ECU.</li> <li>If no external modulator valve is used and all previous checks pass, reconfigure the system to a 2S/2M or 4S/2M system depending on how many sensors are used through the WABCO TOOLBOX™ Software.</li> <li>If equipped with an external modulator, verify resistance from the exhaust and inlet valve to ground is between 4 to 8 ohms through the whole circuit.</li> <li>Verify there is no continuity on any of the pins of the external modulator valve cable to chassis ground.</li> </ul>

SID	FMI	Suspect Component and Location	Fault Description (FMI)	Cause	Repair Information
59	12	External ABS Modulator Valve (pressure sensor)	Pressure differential.	ABS ECU has detected a > 29 psi (2 bar) sensor pressure differential condition on the external modulator valve.	<ul style="list-style-type: none"> <li>Verify an external modulator is installed by checking to see if a cable is plugged in to the external modulator port of the RSS ECU.</li> <li>Verify if no cable is attached that the external modulator cap is sealed and there are no signs of moisture or corrosion on the pins of the RSS ECU.</li> <li>If no external modulator valve is used and all previous checks pass, reconfigure the system to a 2S/2M or 4S/2M system depending on how many sensors are used through the WABCO TOOLBOX™ Software.</li> <li>If equipped with an external modulator, verify resistance from the exhaust and inlet valve to ground is between 4 to 8 ohms through the whole circuit.</li> <li>Verify there is no continuity on any of the pins of the external modulator valve cable to chassis ground.</li> </ul>
59	15	External ABS Modulator Valve (pressure sensor)	Residual pressure.	ABS ECU has detected a > 7 psi (0.5 bar) residual pressure condition on connection	<ul style="list-style-type: none"> <li>Verify an external modulator is installed by checking to see if a cable is plugged in to the external modulator port of the RSS ECU.</li> <li>Verify if no cable is attached that the external modulator cap is sealed and there are no signs of moisture or corrosion on the pins of the RSS ECU.</li> <li>If no external modulator valve is used and all previous checks pass, reconfigure the system to a 2S/2M or 4S/2M system depending on how many sensors are used through the WABCO TOOLBOX™ Software.</li> <li>If there is an external modulator valve, check for trapped air in the control line. If trapped air is found, need to determine source.</li> <li>If equipped with an external modulator, verify resistance from the exhaust and inlet valve to ground is between 4 to 8 ohms through the whole circuit.</li> <li>Verify there is no continuity on any of the pins of the external modulator valve cable to chassis ground.</li> </ul>
61	3	ECU Internal Modulator (redundancy)	Over-voltage/short to supply voltage.	ECU has detected an over-voltage/short to supply voltage condition on the internal modulator.	<ul style="list-style-type: none"> <li>Verify the RSS ECU power connector is seated correctly and has no signs of moisture or corrosion.</li> <li>Verify correct power, ground at the main RSS ECU power connector and load test the power and ground circuit.</li> </ul>
61	4	ECU Internal Modulator (redundancy)	Under-voltage/short to ground.	ECU has detected an under-voltage/short to ground condition on the internal modulator.	<ul style="list-style-type: none"> <li>Verify the RSS ECU power connector is seated correctly and has no signs of moisture or corrosion.</li> <li>Verify correct power, ground at the main RSS ECU power connector and load test the power and ground circuit.</li> </ul>
61	5	ECU Internal Modulator (redundancy)	Open circuit.	ECU has detected an open circuit on the internal modulator.	<ul style="list-style-type: none"> <li>Verify the RSS ECU power connector is seated correctly and has no signs of moisture or corrosion.</li> <li>Verify correct power, ground at the main RSS ECU power connector and load test the power and ground circuit.</li> </ul>
61	6	ECU Internal Modulator (redundancy)	High current/short to ground.	ECU has detected a high current/short to ground condition on the internal modulator.	<ul style="list-style-type: none"> <li>Verify the RSS ECU power connector is seated correctly and has no signs of moisture or corrosion.</li> <li>Verify correct power, ground at the main RSS ECU power connector and load test the power and ground circuit.</li> </ul>

SID	FMI	Suspect Component and Location	Fault Description (FMI)	Cause	Repair Information
61	11	ECU Internal Modulator (redundancy)	Unknown error.	ECU has detected an error condition on the internal modulator.	<ul style="list-style-type: none"> <li>Verify the RSS ECU power connector is seated correctly and has no signs of moisture or corrosion.</li> <li>Verify correct power, ground at the main RSS ECU power connector and load test the power and ground circuit.</li> </ul>
62	0	ECU Internal Modulator (pressure sensors)	Pressure deviation.	ABS ECU has detected a > 7 psi (0.5 bar) pressure deviation between connection 2.2 or 2.1 of the internal modulator valve.	<ul style="list-style-type: none"> <li>Verify the RSS ECU power connector is seated correctly and has no signs of moisture or corrosion.</li> <li>Verify correct power, ground at the main RSS ECU power connector and load test the power and ground circuit.</li> </ul>
62	3	ECU Internal Modulator (pressure sensors)	Over-voltage/short to supply voltage.	ABS ECU has detected an over-voltage/short to supply voltage condition on the internal modulator valve.	<ul style="list-style-type: none"> <li>Verify the RSS ECU power connector is seated correctly and has no signs of moisture or corrosion.</li> <li>Verify correct power, ground at the main RSS ECU power connector and load test the power and ground circuit.</li> </ul>
62	4	ECU Internal Modulator (pressure sensors)	Under-voltage/short to ground.	ABS ECU has detected an under-voltage/short to ground condition on the internal modulator valve.	<ul style="list-style-type: none"> <li>Verify the RSS ECU power connector is seated correctly and has no signs of moisture or corrosion.</li> <li>Verify correct power, ground at the main RSS ECU power connector and load test the power and ground circuit.</li> </ul>
62	11	ECU Internal Modulator (pressure sensors)	Residual pressure.	ECU has detected > 14 psi (1 bar) residual pressure in the brake cylinder line.	<ul style="list-style-type: none"> <li>Verify the RSS ECU power connector is seated correctly and has no signs of moisture or corrosion.</li> <li>Verify correct power, ground at the main RSS ECU power connector and load test the power and ground circuit.</li> </ul>
62	12	ECU Internal Modulator (pressure sensors)	Pressure differential.	ABS ECU has detected a > 29 psi (2 bar) sensor pressure differential condition on the internal modulator valve.	<ul style="list-style-type: none"> <li>Verify the RSS ECU power connector is seated correctly and has no signs of moisture or corrosion.</li> <li>Verify correct power, ground at the main RSS ECU power connector and load test the power and ground circuit.</li> </ul>
62	15	ECU Internal Modulator (pressure sensors)	Residual pressure.	ABS ECU has detected a > 7 psi (0.5 bar) residual pressure condition on connection 2.1 or 2.2 of the internal modulator valve.	<ul style="list-style-type: none"> <li>Verify the RSS ECU power connector is seated correctly and has no signs of moisture or corrosion.</li> <li>Verify correct power, ground at the main RSS ECU power connector and load test the power and ground circuit.</li> </ul>



SID	FMI	Suspect Component and Location	Fault Description (FMI)	Cause	Repair Information
69	2	ECU Internal Modulator (load sensors)	Irregular data.	No axle load transmitted by TCE.	<ul style="list-style-type: none"> <li>Verify pneumatic line is connected from the air bag to port 5.</li> <li>Verify the RSS ECU power connector is seated correctly and has no signs of moisture or corrosion.</li> <li>Verify correct power, ground at the main RSS ECU power connector and load test the power and ground circuit.</li> </ul>
69	3	ECU Internal Modulator (load sensors)	Over-voltage/short to supply voltage.	ECU has detected an over-voltage/short to supply voltage condition on the internal modulator.	<ul style="list-style-type: none"> <li>Verify pneumatic line is connected from the air bag to port 5.</li> <li>Verify the RSS ECU power connector is seated correctly and has no signs of moisture or corrosion.</li> <li>Verify correct power, ground at the main RSS ECU power connector and load test the power and ground circuit.</li> </ul>
69	4	ECU Internal Modulator (load sensors)	Under-voltage/short to ground.	ECU has detected an under-voltage/short to ground condition on the internal modulator.	<ul style="list-style-type: none"> <li>Verify pneumatic line is connected from the air bag to port 5.</li> <li>Verify the RSS ECU power connector is seated correctly and has no signs of moisture or corrosion.</li> <li>Verify correct power, ground at the main RSS ECU power connector and load test the power and ground circuit.</li> </ul>
69	12	ECU Internal Modulator (load sensors)	Pressure too low.	ABS ECU has detected a low pressure condition on the air suspension while driving.	<ul style="list-style-type: none"> <li>Verify pneumatic line is connected from the air bag to port 5.</li> <li>Verify the RSS ECU power connector is seated correctly and has no signs of moisture or corrosion.</li> <li>Verify correct power, ground at the main RSS ECU power connector and load test the power and ground circuit.</li> <li>Check bellows pressure, connectors and fittings.</li> </ul>
75	3	ECU Internal Modulator (brake wear sensors)	Over-voltage/short to supply voltage.	ECU has detected an over-voltage/short to supply voltage condition on the internal modulator.	<ul style="list-style-type: none"> <li>Verify the RSS ECU power connector is seated correctly and has no signs of moisture or corrosion.</li> <li>Verify correct power, ground at the main RSS ECU power connector and load test the power and ground circuit.</li> <li>Check brake wear sensors, connections or cables.</li> </ul>
75	12	ECU Internal Modulator (brake wear sensors)	Brake lining wear.	ABS ECU has detected at least one brake lining is worn.	<ul style="list-style-type: none"> <li>Verify the RSS ECU power connector is seated correctly and has no signs of moisture or corrosion.</li> <li>Verify correct power, ground at the main RSS ECU power connector and load test the power and ground circuit.</li> <li>Check brake linings and wear sensors.</li> </ul>
76	14	ECU Internal Modulator	Braking with redundancy pressures.	ABS ECU is using redundancy pressure, ABS still active.	<ul style="list-style-type: none"> <li>Verify the RSS ECU power connector is seated correctly and has no signs of moisture or corrosion.</li> <li>Verify correct power, ground at the main RSS ECU power connector and load test the power and ground circuit.</li> </ul>



SID	FMI	Suspect Component and Location	Fault Description (FMI)	Cause	Repair Information
77	0	ECU Internal Modulator (pressure sensors)	Measurement error.	Measured pressure value too high.	<ul style="list-style-type: none"> <li>Verify the RSS ECU power connector is seated correctly and has no signs of moisture or corrosion.</li> <li>Verify correct power, ground at the main RSS ECU power connector and load test the power and ground circuit.</li> </ul>
77	1	ECU Internal Modulator (pressure sensors)	Measurement error.	Measured pressure value too low.	<ul style="list-style-type: none"> <li>Verify the RSS ECU power connector is seated correctly and has no signs of moisture or corrosion.</li> <li>Verify correct power, ground at the main RSS ECU power connector and load test the power and ground circuit.</li> <li>Verify lines are not crimped or bent.</li> </ul>
77	3	ECU Internal Modulator (pressure sensors)	Over-voltage/short to supply voltage.	ECU has detected an over-voltage/short to supply voltage condition on the internal pressure sensor.	<ul style="list-style-type: none"> <li>Verify the RSS ECU power connector is seated correctly and has no signs of moisture or corrosion.</li> <li>Verify correct power, ground at the main RSS ECU power connector and load test the power and ground circuit.</li> </ul>
77	4	ECU Internal Modulator (pressure sensors)	Under-voltage/short to ground.	ECU has detected an under-voltage/short to ground condition on the internal pressure sensor.	<ul style="list-style-type: none"> <li>Verify the RSS ECU power connector is seated correctly and has no signs of moisture or corrosion.</li> <li>Verify correct power, ground at the main RSS ECU power connector and load test the power and ground circuit.</li> </ul>
77	11	ECU Internal Modulator (pressure sensors)	Offset error.	ECU has detected an internal pressure sensor offset error.	<ul style="list-style-type: none"> <li>Verify the RSS ECU power connector is seated correctly and has no signs of moisture or corrosion.</li> <li>Verify correct power, ground at the main RSS ECU power connector and load test the power and ground circuit.</li> </ul>
77	12	ECU Internal Modulator (pressure deviation)	Pressure deviation (driving).	ABS ECU has detected a pressure deviation via CAN control pressure.	<ul style="list-style-type: none"> <li>Verify the RSS ECU power connector is seated correctly and has no signs of moisture or corrosion.</li> <li>Verify correct power, ground at the main RSS ECU power connector and load test the power and ground circuit.</li> </ul>
77	13	ECU Internal Modulator (pressure deviation)	Pressure deviation (driving).	ABS ECU has detected a pressure deviation via CAN control pressure.	<ul style="list-style-type: none"> <li>Verify the RSS ECU power connector is seated correctly and has no signs of moisture or corrosion.</li> <li>Verify correct power, ground at the main RSS ECU power connector and load test the power and ground circuit.</li> </ul>
78	0	ECU Internal Modulator (external pressure sensors)	Measurement error.	Measured pressure value too high.	<ul style="list-style-type: none"> <li>Verify the RSS ECU power connector is seated correctly and has no signs of moisture or corrosion.</li> <li>Verify correct power, ground at the main RSS ECU power connector and load test the power and ground circuit.</li> </ul>

SID	FMI	Suspect Component and Location	Fault Description (FMI)	Cause	Repair Information
78	1	ECU Internal Modulator (external pressure sensors)	Measurement error.	Measured pressure value too low.	<ul style="list-style-type: none"> <li>Verify the RSS ECU power connector is seated correctly and has no signs of moisture or corrosion.</li> <li>Verify correct power, ground at the main RSS ECU power connector and load test the power and ground circuit.</li> <li>Verify lines are not crimped or bent.</li> </ul>
78	3	ECU Internal Modulator (external pressure sensors)	Over-voltage/short to supply voltage.	ECU has detected an over-voltage/short to supply voltage condition.	<ul style="list-style-type: none"> <li>Verify the RSS ECU power connector is seated correctly and has no signs of moisture or corrosion.</li> <li>Verify correct power, ground at the main RSS ECU power connector and load test the power and ground circuit.</li> </ul>
78	4	ECU Internal Modulator (external pressure sensors)	Under-voltage/short to ground.	ECU has detected an under-voltage/short to ground condition.	<ul style="list-style-type: none"> <li>Verify the RSS ECU power connector is seated correctly and has no signs of moisture or corrosion.</li> <li>Verify correct power, ground at the main RSS ECU power connector and load test the power and ground circuit.</li> </ul>
78	5	ECU Internal Modulator (external pressure sensors)	Open circuit.	ECU has detected an open circuit condition.	<ul style="list-style-type: none"> <li>Verify the RSS ECU power connector is seated correctly and has no signs of moisture or corrosion.</li> <li>Verify correct power, ground at the main RSS ECU power connector and load test the power and ground circuit.</li> </ul>
78	11	ECU Internal Modulator (external pressure sensors)	Open circuit.	ECU has detected an open circuit condition.	<ul style="list-style-type: none"> <li>Verify the RSS ECU power connector is seated correctly and has no signs of moisture or corrosion.</li> <li>Verify correct power, ground at the main RSS ECU power connector and load test the power and ground circuit.</li> </ul>
78	12	ECU Internal Modulator (external pressure sensor)	Pressure deviation (driving).	ABS ECU has detected a pressure deviation via CAN control pressure.	<ul style="list-style-type: none"> <li>Verify the RSS ECU power connector is seated correctly and has no signs of moisture or corrosion.</li> <li>Verify correct power, ground at the main RSS ECU power connector and load test the power and ground circuit.</li> </ul>
78	13	ECU Internal Modulator (external pressure sensor)	Pressure deviation (driving).	ABS ECU has detected a pressure deviation via CAN control pressure.	<ul style="list-style-type: none"> <li>Verify the RSS ECU power connector is seated correctly and has no signs of moisture or corrosion.</li> <li>Verify correct power, ground at the main RSS ECU power connector and load test the power and ground circuit.</li> </ul>
88	0	Lateral Acceleration Sensor	Invalid modulator position.	ABS ECU has detected a lateral acceleration positioning error.	<ul style="list-style-type: none"> <li>Verify modulator is in the correct position and reposition if necessary.</li> </ul>
88	1	Lateral Acceleration Sensor	Invalid modulator position. Value too low.	ABS ECU has detected a lateral acceleration positioning error.	<ul style="list-style-type: none"> <li>Verify modulator is in the correct position and reposition if necessary.</li> </ul>

SID	FMI	Suspect Component and Location	Fault Description (FMI)	Cause	Repair Information
88	2	Lateral Acceleration Sensor	Irregular or incorrect data.	ABS ECU has detected a lateral acceleration error.	<ul style="list-style-type: none"> <li>Verify the RSS ECU power connector is seated correctly and has no signs of moisture or corrosion.</li> <li>Verify correct power, ground at the main RSS ECU power connector and load test the power and ground circuit.</li> </ul>
88	11	Lateral Acceleration Sensor	Irregular or incorrect data (driving).	ABS ECU has detected a lateral acceleration error.	<ul style="list-style-type: none"> <li>Verify the RSS ECU power connector is seated correctly and has no signs of moisture or corrosion.</li> <li>Verify correct power, ground at the main RSS ECU power connector and load test the power and ground circuit.</li> </ul>
88	12	Lateral Acceleration Sensor	Lateral acceleration error.	ABS ECU has detected a lateral acceleration error.	<ul style="list-style-type: none"> <li>Verify the RSS ECU power connector is seated correctly and has no signs of moisture or corrosion.</li> <li>Verify correct power, ground at the main RSS ECU power connector and load test the power and ground circuit.</li> </ul>
90	3	ECU GIO Function 8 (freely configurable)	Short circuit to supply.	ECU has detected a short circuit of the GIO to supply.	<ul style="list-style-type: none"> <li>Verify the RSS ECU power connector is seated correctly and has no signs of moisture or corrosion.</li> <li>Verify correct power, ground at the main RSS ECU power connector and load test the power and ground circuit.</li> <li>Verify GIO cable is securely connected to the ECU and application dependent component. Check cable for shorts or opens. If cable tests correctly, inspect component for correct operation.</li> </ul>
90	4	ECU GIO Function 8 (freely configurable)	Short circuit to ground.	ECU has detected a short circuit of the GIO to ground.	<ul style="list-style-type: none"> <li>Verify the RSS ECU power connector is seated correctly and has no signs of moisture or corrosion.</li> <li>Verify correct power, ground at the main RSS ECU power connector and load test the power and ground circuit.</li> <li>Verify GIO cable is securely connected to the ECU and application dependent component. Check cable for shorts or opens. If cable tests correctly, inspect component for correct operation.</li> </ul>
90	5	ECU GIO Function 8 (freely configurable)	Open circuit (cable break).	ECU has detected an open circuit of the GIO.	<ul style="list-style-type: none"> <li>Verify the RSS ECU power connector is seated correctly and has no signs of moisture or corrosion.</li> <li>Verify correct power, ground at the main RSS ECU power connector and load test the power and ground circuit.</li> <li>Verify GIO cable is securely connected to the ECU and application dependent component. Check cable for shorts or opens. If cable tests correctly, inspect component for correct operation.</li> </ul>

SID	FMI	Suspect Component and Location	Fault Description (FMI)	Cause	Repair Information
91	3	ECU GIO Function 7 (freely configurable)	Short circuit to supply.	ECU has detected a short circuit of the GIO to supply.	<ul style="list-style-type: none"> <li>Verify the RSS ECU power connector is seated correctly and has no signs of moisture or corrosion.</li> <li>Verify correct power, ground at the main RSS ECU power connector and load test the power and ground circuit.</li> <li>Verify GIO cable is securely connected to the ECU and application dependent component. Check cable for shorts or opens. If cable tests correctly, inspect component for correct operation.</li> </ul>
91	4	ECU GIO Function 7 (freely configurable)	Short circuit to ground.	ECU has detected a short circuit of the GIO to ground.	<ul style="list-style-type: none"> <li>Verify the RSS ECU power connector is seated correctly and has no signs of moisture or corrosion.</li> <li>Verify correct power, ground at the main RSS ECU power connector and load test the power and ground circuit.</li> <li>Verify GIO cable is securely connected to the ECU and application dependent component. Check cable for shorts or opens. If cable tests correctly, inspect component for correct operation.</li> </ul>
91	5	ECU GIO Function 7 (freely configurable)	Open circuit (cable break).	ECU has detected an open circuit of the GIO.	<ul style="list-style-type: none"> <li>Verify the RSS ECU power connector is seated correctly and has no signs of moisture or corrosion.</li> <li>Verify correct power, ground at the main RSS ECU power connector and load test the power and ground circuit.</li> <li>Verify GIO cable is securely connected to the ECU and application dependent component. Check cable for shorts or opens. If cable tests correctly, inspect component for correct operation.</li> </ul>
92	3	ECU GIO Function 6 (freely configurable)	Short circuit to supply.	ECU has detected a short circuit of the GIO to supply.	<ul style="list-style-type: none"> <li>Verify the RSS ECU power connector is seated correctly and has no signs of moisture or corrosion.</li> <li>Verify correct power, ground at the main RSS ECU power connector and load test the power and ground circuit.</li> <li>Verify GIO cable is securely connected to the ECU and application dependent component. Check cable for shorts or opens. If cable tests correctly, inspect component for correct operation.</li> </ul>
92	4	ECU GIO Function 6 (freely configurable)	Short circuit to ground.	ECU has detected a short circuit of the GIO to ground.	<ul style="list-style-type: none"> <li>Verify the RSS ECU power connector is seated correctly and has no signs of moisture or corrosion.</li> <li>Verify correct power, ground at the main RSS ECU power connector and load test the power and ground circuit.</li> <li>Verify GIO cable is securely connected to the ECU and application dependent component. Check cable for shorts or opens. If cable tests correctly, inspect component for correct operation.</li> </ul>

SID	FMI	Suspect Component and Location	Fault Description (FMI)	Cause	Repair Information
92	5	ECU GIO Function 6 (freely configurable)	Open circuit (cable break).	ECU has detected an open circuit of the GIO.	<ul style="list-style-type: none"> <li>• Verify the RSS ECU power connector is seated correctly and has no signs of moisture or corrosion.</li> <li>• Verify correct power, ground at the main RSS ECU power connector and load test the power and ground circuit.</li> <li>• Verify GIO cable is securely connected to the ECU and application dependent component. Check cable for shorts or opens. If cable tests correctly, inspect component for correct operation.</li> </ul>
93	3	ECU GIO Function 5 (freely configurable)	Short circuit to supply.	ECU has detected a short circuit of the GIO to supply.	<ul style="list-style-type: none"> <li>• Verify the RSS ECU power connector is seated correctly and has no signs of moisture or corrosion.</li> <li>• Verify correct power, ground at the main RSS ECU power connector and load test the power and ground circuit.</li> <li>• Verify GIO cable is securely connected to the ECU and application dependent component. Check cable for shorts or opens. If cable tests correctly, inspect component for correct operation.</li> </ul>
93	4	ECU GIO Function 5 (freely configurable)	Short circuit to ground.	ECU has detected a short circuit of the GIO to ground.	<ul style="list-style-type: none"> <li>• Verify the RSS ECU power connector is seated correctly and has no signs of moisture or corrosion.</li> <li>• Verify correct power, ground at the main RSS ECU power connector and load test the power and ground circuit.</li> <li>• Verify GIO cable is securely connected to the ECU and application dependent component. Check cable for shorts or opens. If cable tests correctly, inspect component for correct operation.</li> </ul>
93	5	ECU GIO Function 5 (freely configurable)	Open circuit (cable break).	ECU has detected an open circuit of the GIO.	<ul style="list-style-type: none"> <li>• Verify the RSS ECU power connector is seated correctly and has no signs of moisture or corrosion.</li> <li>• Verify correct power, ground at the main RSS ECU power connector and load test the power and ground circuit.</li> <li>• Verify GIO cable is securely connected to the ECU and application dependent component. Check cable for shorts or opens. If cable tests correctly, inspect component for correct operation.</li> </ul>
94	3	ECU GIO Function 4 (freely configurable)	Short circuit to supply.	ECU has detected a short circuit of the GIO to supply.	<ul style="list-style-type: none"> <li>• Verify the RSS ECU power connector is seated correctly and has no signs of moisture or corrosion.</li> <li>• Verify correct power, ground at the main RSS ECU power connector and load test the power and ground circuit.</li> <li>• Verify GIO cable is securely connected to the ECU and application dependent component. Check cable for shorts or opens. If cable tests correctly, inspect component for correct operation.</li> </ul>

# Diagnostics

SID	FMI	Suspect Component and Location	Fault Description (FMI)	Cause	Repair Information
94	4	ECU GIO Function 4 (freely configurable)	Short circuit to ground.	ECU has detected a short circuit of the GIO to ground.	<ul style="list-style-type: none"> <li>• Verify the RSS ECU power connector is seated correctly and has no signs of moisture or corrosion.</li> <li>• Verify correct power, ground at the main RSS ECU power connector and load test the power and ground circuit.</li> <li>• Verify GIO cable is securely connected to the ECU and application dependent component. Check cable for shorts or opens. If cable tests correctly, inspect component for correct operation.</li> </ul>
94	5	ECU GIO Function 4 (freely configurable)	Open circuit (cable break).	ECU has detected an open circuit of the GIO.	<ul style="list-style-type: none"> <li>• Verify the RSS ECU power connector is seated correctly and has no signs of moisture or corrosion.</li> <li>• Verify correct power, ground at the main RSS ECU power connector and load test the power and ground circuit.</li> <li>• Verify GIO cable is securely connected to the ECU and application dependent component. Check cable for shorts or opens. If cable tests correctly, inspect component for correct operation.</li> </ul>
95	3	ECU GIO Function 3 (freely configurable)	Short circuit to supply.	ECU has detected a short circuit of the GIO to supply.	<ul style="list-style-type: none"> <li>• Verify the RSS ECU power connector is seated correctly and has no signs of moisture or corrosion.</li> <li>• Verify correct power, ground at the main RSS ECU power connector and load test the power and ground circuit.</li> <li>• Verify GIO cable is securely connected to the ECU and application dependent component. Check cable for shorts or opens. If cable tests correctly, inspect component for correct operation.</li> </ul>
95	4	ECU GIO Function 3 (freely configurable)	Short circuit to ground.	ECU has detected a short circuit of the GIO to ground.	<ul style="list-style-type: none"> <li>• Verify the RSS ECU power connector is seated correctly and has no signs of moisture or corrosion.</li> <li>• Verify correct power, ground at the main RSS ECU power connector and load test the power and ground circuit.</li> <li>• Verify GIO cable is securely connected to the ECU and application dependent component. Check cable for shorts or opens. If cable tests correctly, inspect component for correct operation.</li> </ul>
95	5	ECU GIO Function 3 (freely configurable)	Open circuit (cable break).	ECU has detected an open circuit of the GIO.	<ul style="list-style-type: none"> <li>• Verify the RSS ECU power connector is seated correctly and has no signs of moisture or corrosion.</li> <li>• Verify correct power, ground at the main RSS ECU power connector and load test the power and ground circuit.</li> <li>• Verify GIO cable is securely connected to the ECU and application dependent component. Check cable for shorts or opens. If cable tests correctly, inspect component for correct operation.</li> </ul>

SID	FMI	Suspect Component and Location	Fault Description (FMI)	Cause	Repair Information
96	3	ECU GIO Function 2 (freely configurable)	Short circuit to supply.	ECU has detected a short circuit of the GIO to supply.	<ul style="list-style-type: none"> <li>Verify the RSS ECU power connector is seated correctly and has no signs of moisture or corrosion.</li> <li>Verify correct power, ground at the main RSS ECU power connector and load test the power and ground circuit.</li> <li>Verify GIO cable is securely connected to the ECU and application dependent component. Check cable for shorts or opens. If cable tests correctly, inspect component for correct operation.</li> </ul>
96	4	ECU GIO Function 2 (freely configurable)	Short circuit to ground.	ECU has detected a short circuit of the GIO to ground.	<ul style="list-style-type: none"> <li>Verify the RSS ECU power connector is seated correctly and has no signs of moisture or corrosion.</li> <li>Verify correct power, ground at the main RSS ECU power connector and load test the power and ground circuit.</li> <li>Verify GIO cable is securely connected to the ECU and application dependent component. Check cable for shorts or opens. If cable tests correctly, inspect component for correct operation.</li> </ul>
96	5	ECU GIO Function 2 (freely configurable)	Open circuit (cable break).	ECU has detected an open circuit of the GIO.	<ul style="list-style-type: none"> <li>Verify the RSS ECU power connector is seated correctly and has no signs of moisture or corrosion.</li> <li>Verify correct power, ground at the main RSS ECU power connector and load test the power and ground circuit.</li> <li>Verify GIO cable is securely connected to the ECU and application dependent component. Check cable for shorts or opens. If cable tests correctly, inspect component for correct operation.</li> </ul>
97	3	ECU GIO Function 1 (freely configurable)	Short circuit to supply.	ECU has detected a short circuit of the GIO to supply.	<ul style="list-style-type: none"> <li>Verify the RSS ECU power connector is seated correctly and has no signs of moisture or corrosion.</li> <li>Verify correct power, ground at the main RSS ECU power connector and load test the power and ground circuit.</li> <li>Verify GIO cable is securely connected to the ECU and application dependent component. Check cable for shorts or opens. If cable tests correctly, inspect component for correct operation.</li> </ul>
97	4	ECU GIO Function 1 (freely configurable)	Short circuit to ground.	ECU has detected a short circuit of the GIO to ground.	<ul style="list-style-type: none"> <li>Verify the RSS ECU power connector is seated correctly and has no signs of moisture or corrosion.</li> <li>Verify correct power, ground at the main RSS ECU power connector and load test the power and ground circuit.</li> <li>Verify GIO cable is securely connected to the ECU and application dependent component. Check cable for shorts or opens. If cable tests correctly, inspect component for correct operation.</li> </ul>

# Diagnostics

SID	FMI	Suspect Component and Location	Fault Description (FMI)	Cause	Repair Information
97	5	ECU GIO Function 1 (freely configurable)	Open circuit (cable break).	ECU has detected an open circuit of the GIO.	<ul style="list-style-type: none"> <li>Verify the RSS ECU power connector is seated correctly and has no signs of moisture or corrosion.</li> <li>Verify correct power, ground at the main RSS ECU power connector and load test the power and ground circuit.</li> <li>Verify GIO cable is securely connected to the ECU and application dependent component. Check cable for shorts or opens. If cable tests correctly, inspect component for correct operation.</li> </ul>
98	3	Slider Status	Over-voltage or short to batt.	Slider Status (input) over-voltage or short to batt detected.	<ul style="list-style-type: none"> <li>Verify the RSS ECU power connector is seated correctly and has no signs of moisture or corrosion.</li> <li>Verify correct power, ground at the main RSS ECU power connector and load test the power and ground circuit.</li> <li>Verify GIO cable is securely connected to the ECU and application dependent component. Check cable for shorts or opens. If cable tests correctly, inspect component for correct operation.</li> </ul>
99	3	Slot GIO In/Out	Over-voltage or short to supply.	Cable over-voltage or short to supply detected.	<ul style="list-style-type: none"> <li>Verify the RSS ECU power connector is seated correctly and has no signs of moisture or corrosion.</li> <li>Verify correct power, ground at the main RSS ECU power connector and load test the power and ground circuit.</li> <li>Verify GIO cable is securely connected to the ECU and application dependent component. Check cable for shorts or opens. If cable tests correctly, inspect component for correct operation.</li> </ul>
99	4	Slot GIO In/Out	Under-voltage or short to ground.	Cable under-voltage or short to ground detected.	<ul style="list-style-type: none"> <li>Verify the RSS ECU power connector is seated correctly and has no signs of moisture or corrosion.</li> <li>Verify correct power, ground at the main RSS ECU power connector and load test the power and ground circuit.</li> <li>Verify GIO cable is securely connected to the ECU and application dependent component. Check cable for shorts or opens. If cable tests correctly, inspect component for correct operation.</li> </ul>
99	11	Slot GIO In/Out	Component missing parameters.	A component with undefined parameters detected.	<ul style="list-style-type: none"> <li>Verify correct installation and that the correct parameters are set for the application.</li> </ul>
100	3	ECU GIO Analog Function (freely configurable)	Over-voltage or short to supply.	Over-voltage or short circuit of the GIO cable detected.	<ul style="list-style-type: none"> <li>Verify the RSS ECU power connector is seated correctly and has no signs of moisture or corrosion.</li> <li>Verify correct power, ground at the main RSS ECU power connector and load test the power and ground circuit.</li> <li>Verify GIO cable is securely connected to the ECU and application dependent component. Check cable for shorts or opens. If cable tests correctly, inspect component for correct operation.</li> </ul>



SID	FMI	Suspect Component and Location	Fault Description (FMI)	Cause	Repair Information
100	4	ECU GIO Analog Function (freely configurable)	Under-voltage or short to ground.	Under-voltage or short circuit of the GIO cable detected.	<ul style="list-style-type: none"> <li>Verify the RSS ECU power connector is seated correctly and has no signs of moisture or corrosion.</li> <li>Verify correct power, ground at the main RSS ECU power connector and load test the power and ground circuit.</li> <li>Verify GIO cable is securely connected to the ECU and application dependent component. Check cable for shorts or opens. If cable tests correctly, inspect component for correct operation.</li> </ul>
100	5	ECU GIO Analog Function (freely configurable)	Open circuit.	Open circuit (cable break) of the GIO cable detected.	<ul style="list-style-type: none"> <li>Verify the RSS ECU power connector is seated correctly and has no signs of moisture or corrosion.</li> <li>Verify correct power, ground at the main RSS ECU power connector and load test the power and ground circuit.</li> <li>Verify GIO cable is securely connected to the ECU and application dependent component. Check cable for shorts or opens. If cable tests correctly, inspect component for correct operation.</li> </ul>
101	2	ECU GIO Digital Function (freely configurable)	Data is irregular or incorrect.	Cable is not connected or is defective.	<ul style="list-style-type: none"> <li>Verify the RSS ECU power connector is seated correctly and has no signs of moisture or corrosion.</li> <li>Verify correct power, ground at the main RSS ECU power connector and load test the power and ground circuit.</li> <li>Verify GIO cable is securely connected to the ECU and application dependent component. Check cable for shorts or opens. If cable tests correctly, inspect component for correct operation.</li> </ul>
101	3	ECU GIO Digital Function (freely configurable)	Over-voltage or short to supply.	Over-voltage or short circuit of the GIO cable detected.	<ul style="list-style-type: none"> <li>Verify the RSS ECU power connector is seated correctly and has no signs of moisture or corrosion.</li> <li>Verify correct power, ground at the main RSS ECU power connector and load test the power and ground circuit.</li> <li>Verify GIO cable is securely connected to the ECU and application dependent component. Check cable for shorts or opens. If cable tests correctly, inspect component for correct operation.</li> </ul>
101	4	ECU GIO Digital Function (freely configurable)	Under-voltage or short to ground.	Under-voltage or short circuit of the GIO cable detected.	<ul style="list-style-type: none"> <li>Verify the RSS ECU power connector is seated correctly and has no signs of moisture or corrosion.</li> <li>Verify correct power, ground at the main RSS ECU power connector and load test the power and ground circuit.</li> <li>Verify GIO cable is securely connected to the ECU and application dependent component. Check cable for shorts or opens. If cable tests correctly, inspect component for correct operation.</li> </ul>

SID	FMI	Suspect Component and Location	Fault Description (FMI)	Cause	Repair Information
101	5	ECU GIO Digital Function (freely configurable)	Open circuit.	Open circuit (cable break) of the GIO cable detected.	<ul style="list-style-type: none"> <li>Verify the RSS ECU power connector is seated correctly and has no signs of moisture or corrosion.</li> <li>Verify correct power, ground at the main RSS ECU power connector and load test the power and ground circuit.</li> <li>Verify GIO cable is securely connected to the ECU and application dependent component. Check cable for shorts or opens. If cable tests correctly, inspect component for correct operation.</li> </ul>
102	3	ECU GIO SLOT 5	Over-voltage or short circuit to supply.	Over-voltage or short circuit of the GIO detected.	<ul style="list-style-type: none"> <li>Verify the RSS ECU power connector is seated correctly and has no signs of moisture or corrosion.</li> <li>Verify correct power, ground at the main RSS ECU power connector and load test the power and ground circuit.</li> <li>Verify GIO cable is securely connected to the ECU and application dependent component. Check cable for shorts or opens. If cable tests correctly, inspect component for correct operation.</li> </ul>
102	4	ECU GIO SLOT 5	Under-voltage or short circuit to ground.	Under-voltage or short circuit of the GIO detected.	<ul style="list-style-type: none"> <li>Verify the RSS ECU power connector is seated correctly and has no signs of moisture or corrosion.</li> <li>Verify correct power, ground at the main RSS ECU power connector and load test the power and ground circuit.</li> <li>Verify GIO cable is securely connected to the ECU and application dependent component. Check cable for shorts or opens. If cable tests correctly, inspect component for correct operation.</li> </ul>
102	11	ECU GIO SLOT 5	Component missing parameters.	A component with undefined parameters detected.	<ul style="list-style-type: none"> <li>Verify correct installation and that the correct parameters are set for the application.</li> </ul>
103	3	ECU GIO SLOT 4	Over-voltage or short circuit to supply.	Over-voltage or short circuit of the GIO detected.	<ul style="list-style-type: none"> <li>Verify the RSS ECU power connector is seated correctly and has no signs of moisture or corrosion.</li> <li>Verify correct power, ground at the main RSS ECU power connector and load test the power and ground circuit.</li> <li>Verify GIO cable is securely connected to the ECU and application dependent component. Check cable for shorts or opens. If cable tests correctly, inspect component for correct operation.</li> </ul>
103	4	ECU GIO SLOT 4	Under-voltage or short circuit to ground.	Under-voltage or short circuit of the GIO detected.	<ul style="list-style-type: none"> <li>Verify the RSS ECU power connector is seated correctly and has no signs of moisture or corrosion.</li> <li>Verify correct power, ground at the main RSS ECU power connector and load test the power and ground circuit.</li> <li>Verify GIO cable is securely connected to the ECU and application dependent component. Check cable for shorts or opens. If cable tests correctly, inspect component for correct operation.</li> </ul>

SID	FMI	Suspect Component and Location	Fault Description (FMI)	Cause	Repair Information
103	11	ECU GIO SLOT 4	Component missing parameters.	A component with undefined parameters detected.	<ul style="list-style-type: none"> <li>Verify correct installation and that the correct parameters are set for the application.</li> </ul>
104	3	ECU GIO SLOT 3	Over-voltage or short circuit to supply.	Over-voltage or short circuit of the GIO detected.	<ul style="list-style-type: none"> <li>Verify the RSS ECU power connector is seated correctly and has no signs of moisture or corrosion.</li> <li>Verify correct power, ground at the main RSS ECU power connector and load test the power and ground circuit.</li> <li>Verify GIO cable is securely connected to the ECU and application dependent component. Check cable for shorts or opens. If cable tests correctly, inspect component for correct operation.</li> </ul>
104	4	ECU GIO SLOT 3	Under-voltage or short circuit to ground.	Under-voltage or short circuit of the GIO detected.	<ul style="list-style-type: none"> <li>Verify the RSS ECU power connector is seated correctly and has no signs of moisture or corrosion.</li> <li>Verify correct power, ground at the main RSS ECU power connector and load test the power and ground circuit.</li> <li>Verify GIO cable is securely connected to the ECU and application dependent component. Check cable for shorts or opens. If cable tests correctly, inspect component for correct operation.</li> </ul>
104	11	ECU GIO SLOT 3	Component missing parameters.	A component with undefined parameters detected.	<ul style="list-style-type: none"> <li>Verify the RSS ECU power connector is seated correctly and has no signs of moisture or corrosion.</li> <li>Verify correct power, ground at the main RSS ECU power connector and load test the power and ground circuit.</li> </ul>
105	3	ECU GIO SLOT 2	Over-voltage or short circuit to supply.	Over-voltage or short circuit of the GIO detected.	<ul style="list-style-type: none"> <li>Verify the RSS ECU power connector is seated correctly and has no signs of moisture or corrosion.</li> <li>Verify correct power, ground at the main RSS ECU power connector and load test the power and ground circuit.</li> <li>Verify GIO cable is securely connected to the ECU and application dependent component. Check cable for shorts or opens. If cable tests correctly, inspect component for correct operation.</li> </ul>
105	4	ECU GIO SLOT 2	Under-voltage or short circuit to ground.	Under-voltage or short circuit of the GIO detected.	<ul style="list-style-type: none"> <li>Verify the RSS ECU power connector is seated correctly and has no signs of moisture or corrosion.</li> <li>Verify correct power, ground at the main RSS ECU power connector and load test the power and ground circuit.</li> <li>Verify GIO cable is securely connected to the ECU and application dependent component. Check cable for shorts or opens. If cable tests correctly, inspect component for correct operation.</li> </ul>

SID	FMI	Suspect Component and Location	Fault Description (FMI)	Cause	Repair Information
105	11	ECU GIO SLOT 2	Component missing parameters.	A component with undefined parameters detected.	<ul style="list-style-type: none"> <li>Verify the RSS ECU power connector is seated correctly and has no signs of moisture or corrosion.</li> <li>Verify correct power, ground at the main RSS ECU power connector and load test the power and ground circuit.</li> <li>Verify GIO cable is securely connected to the ECU and application dependent component. Check cable for shorts or opens. If cable tests correctly, inspect component for correct operation.</li> </ul>
106	3	ECU GIO SLOT 1	Over-voltage or short circuit to supply.	Over-voltage or short circuit of the GIO detected.	<ul style="list-style-type: none"> <li>Verify the RSS ECU power connector is seated correctly and has no signs of moisture or corrosion.</li> <li>Verify correct power, ground at the main RSS ECU power connector and load test the power and ground circuit.</li> <li>Verify GIO cable is securely connected to the ECU and application dependent component. Check cable for shorts or opens. If cable tests correctly, inspect component for correct operation.</li> </ul>
106	4	ECU GIO SLOT 1	Under-voltage or short circuit to ground.	Under-voltage or short circuit of the GIO detected.	<ul style="list-style-type: none"> <li>Verify the RSS ECU power connector is seated correctly and has no signs of moisture or corrosion.</li> <li>Verify correct power, ground at the main RSS ECU power connector and load test the power and ground circuit.</li> <li>Verify GIO cable is securely connected to the ECU and application dependent component. Check cable for shorts or opens. If cable tests correctly, inspect component for correct operation.</li> </ul>
106	11	ECU GIO SLOT 1	Component missing parameters.	A component with undefined parameters detected.	<ul style="list-style-type: none"> <li>Verify correct installation and that the correct parameters are set for the application.</li> </ul>
107	3	ECU GIO SLOT 6	Over-voltage or short circuit to supply.	Over-voltage or short circuit of the GIO detected.	<ul style="list-style-type: none"> <li>Verify the RSS ECU power connector is seated correctly and has no signs of moisture or corrosion.</li> <li>Verify correct power, ground at the main RSS ECU power connector and load test the power and ground circuit.</li> <li>Verify GIO cable is securely connected to the ECU and application dependent component. Check cable for shorts or opens. If cable tests correctly, inspect component for correct operation.</li> </ul>
107	4	ECU GIO SLOT 6	Under-voltage or short circuit to ground.	Under-voltage or short circuit of the GIO detected.	<ul style="list-style-type: none"> <li>Verify the RSS ECU power connector is seated correctly and has no signs of moisture or corrosion.</li> <li>Verify correct power, ground at the main RSS ECU power connector and load test the power and ground circuit.</li> <li>Verify GIO cable is securely connected to the ECU and application dependent component. Check cable for shorts or opens. If cable tests correctly, inspect component for correct operation.</li> </ul>

SID	FMI	Suspect Component and Location	Fault Description (FMI)	Cause	Repair Information
107	11	ECU GIO SLOT 6	Component missing parameters.	A component with undefined parameters detected.	<ul style="list-style-type: none"> <li>Verify correct installation and that the correct parameters are set for the application.</li> </ul>
108	3	ECU GIO SLOT 7	Over-voltage or short circuit to supply.	Over-voltage or short circuit of the GIO detected.	<ul style="list-style-type: none"> <li>Verify the RSS ECU power connector is seated correctly and has no signs of moisture or corrosion.</li> <li>Verify correct power, ground at the main RSS ECU power connector and load test the power and ground circuit.</li> <li>Verify GIO cable is securely connected to the ECU and application dependent component. Check cable for shorts or opens. If cable tests correctly, inspect component for correct operation.</li> </ul>
108	4	ECU GIO SLOT 7	Under-voltage or short circuit to ground.	Under-voltage or short circuit of the GIO detected.	<ul style="list-style-type: none"> <li>Verify the RSS ECU power connector is seated correctly and has no signs of moisture or corrosion.</li> <li>Verify correct power, ground at the main RSS ECU power connector and load test the power and ground circuit.</li> <li>Verify GIO cable is securely connected to the ECU and application dependent component. Check cable for shorts or opens. If cable tests correctly, inspect component for correct operation.</li> </ul>
108	11	ECU GIO SLOT 7	Component missing parameters.	A component with undefined parameters detected.	<ul style="list-style-type: none"> <li>Verify correct installation and that the correct parameters are set for the application.</li> </ul>
109	14	ABS Sensor Memory Bit	Special fault sensor memory bit.	Vehicle has been stationary with ignition on too long.	<ul style="list-style-type: none"> <li>Verify the RSS ECU power connector is seated correctly and has no signs of moisture or corrosion.</li> <li>Verify correct power, ground at the main RSS ECU power connector and load test the power and ground circuit.</li> <li>Spin all wheels or drive the trailer while the trailer is powered up; light should extinguish. Verify all sensors can be seen by the ECU using the Sensor Test within TOOLBOX™ Software.</li> </ul>
110	3	ECU GIO SLOT SUBSYSTEMS	Over-voltage or short circuit to supply.	Over-voltage or short circuit of the GIO detected.	<ul style="list-style-type: none"> <li>Verify the RSS ECU power connector is seated correctly and has no signs of moisture or corrosion.</li> <li>Verify correct power, ground at the main RSS ECU power connector and load test the power and ground circuit.</li> <li>Verify GIO cable is securely connected to the ECU and application dependent component. Check cable for shorts or opens. If cable tests correctly, inspect component for correct operation.</li> </ul>

SID	FMI	Suspect Component and Location	Fault Description (FMI)	Cause	Repair Information
110	4	ECU GIO SLOT SUBSYSTEMS	Under-voltage or short circuit to ground.	Under-voltage or short circuit of the GIO detected.	<ul style="list-style-type: none"> <li>Verify the RSS ECU power connector is seated correctly and has no signs of moisture or corrosion.</li> <li>Verify correct power, ground at the main RSS ECU power connector and load test the power and ground circuit.</li> <li>Verify GIO cable is securely connected to the ECU and application dependent component. Check cable for shorts or opens. If cable tests correctly, inspect component for correct operation.</li> </ul>
110	11	ECU GIO SLOT SUBSYSTEMS	Component missing parameters.	A component with undefined parameters detected.	<ul style="list-style-type: none"> <li>Verify correct installation and that the correct parameters are set for the application.</li> </ul>
111	3	Button Relaxation Function	Over-voltage or short to supply.	Cable may be defective.	<ul style="list-style-type: none"> <li>Verify the RSS ECU power connector is seated correctly and has no signs of moisture or corrosion.</li> <li>Verify correct power, ground at the main RSS ECU power connector and load test the power and ground circuit.</li> <li>Verify cable integrity and assure it is seated correctly and has no signs of moisture or corrosion.</li> </ul>
112	3	Button Forced Lowering	Over-voltage or short to supply.	Cable may be defective.	<ul style="list-style-type: none"> <li>Verify the RSS ECU power connector is seated correctly and has no signs of moisture or corrosion.</li> <li>Verify correct power, ground at the main RSS ECU power connector and load test the power and ground circuit.</li> <li>Verify cable integrity and assure it is seated correctly and has no signs of moisture or corrosion.</li> </ul>
113	3	Smartboard	Over-voltage or short to supply.	Cable may be defective.	<ul style="list-style-type: none"> <li>Verify the RSS ECU power connector is seated correctly and has no signs of moisture or corrosion.</li> <li>Verify correct power, ground at the main RSS ECU power connector and load test the power and ground circuit.</li> <li>Verify cable integrity and assure it is seated correctly and has no signs of moisture or corrosion.</li> </ul>
113	4	Smartboard	Under-voltage or short to ground.	Cable may be defective.	<ul style="list-style-type: none"> <li>Verify the RSS ECU power connector is seated correctly and has no signs of moisture or corrosion.</li> <li>Verify correct power, ground at the main RSS ECU power connector and load test the power and ground circuit.</li> <li>Verify cable integrity and assure it is seated correctly and has no signs of moisture or corrosion.</li> </ul>

# Diagnostics

SID	FMI	Suspect Component and Location	Fault Description (FMI)	Cause	Repair Information
114	3	Diagnostic Voltage Supply	Over-voltage or short to supply.	Cable may be defective.	<ul style="list-style-type: none"> <li>Verify the RSS ECU power connector is seated correctly and has no signs of moisture or corrosion.</li> <li>Verify correct power, ground at the main RSS ECU power connector and load test the power and ground circuit.</li> <li>Verify cable integrity and assure it is seated correctly and has no signs of moisture or corrosion.</li> </ul>
114	4	Diagnostic Voltage Supply	Under-voltage or short to ground.	Cable may be defective.	<ul style="list-style-type: none"> <li>Verify the RSS ECU power connector is seated correctly and has no signs of moisture or corrosion.</li> <li>Verify correct power, ground at the main RSS ECU power connector and load test the power and ground circuit.</li> <li>Verify cable integrity and assure it is seated correctly and has no signs of moisture or corrosion.</li> </ul>
115	3	Telematics	Over-voltage or short to supply.	Cable may be defective.	<ul style="list-style-type: none"> <li>Verify the RSS ECU power connector is seated correctly and has no signs of moisture or corrosion.</li> <li>Verify correct power, ground at the main RSS ECU power connector and load test the power and ground circuit.</li> <li>Verify cable integrity and assure it is seated correctly and has no signs of moisture or corrosion.</li> </ul>
115	4	Telematics	Under-voltage or short to ground.	Cable may be defective.	<ul style="list-style-type: none"> <li>Verify the RSS ECU power connector is seated correctly and has no signs of moisture or corrosion.</li> <li>Verify correct power, ground at the main RSS ECU power connector and load test the power and ground circuit.</li> <li>Verify cable integrity and assure it is seated correctly and has no signs of moisture or corrosion.</li> </ul>
116	3	IVTM	Over-voltage or short to supply.	Cable may be defective.	<ul style="list-style-type: none"> <li>Verify the RSS ECU power connector is seated correctly and has no signs of moisture or corrosion.</li> <li>Verify correct power, ground at the main RSS ECU power connector and load test the power and ground circuit.</li> <li>Verify cable integrity and assure it is seated correctly and has no signs of moisture or corrosion.</li> </ul>
116	4	IVTM	Under-voltage or short to ground.	Cable may be defective.	<ul style="list-style-type: none"> <li>Verify the RSS ECU power connector is seated correctly and has no signs of moisture or corrosion.</li> <li>Verify correct power, ground at the main RSS ECU power connector and load test the power and ground circuit.</li> <li>Verify cable integrity and assure it is seated correctly and has no signs of moisture or corrosion.</li> </ul>

SID	FMI	Suspect Component and Location	Fault Description (FMI)	Cause	Repair Information
117	2	ECAS Control Unit	Data is irregular or incorrect.	Cable may be defective.	<ul style="list-style-type: none"> <li>Verify the RSS ECU power connector is seated correctly and has no signs of moisture or corrosion.</li> <li>Verify correct power, ground at the main RSS ECU power connector and load test the power and ground circuit.</li> <li>Verify cable integrity and assure it is seated correctly and has no signs of moisture or corrosion.</li> </ul>
117	3	ECAS Control Unit	Over-voltage or short to supply.	Cable may be defective.	<ul style="list-style-type: none"> <li>Verify the RSS ECU power connector is seated correctly and has no signs of moisture or corrosion.</li> <li>Verify correct power, ground at the main RSS ECU power connector and load test the power and ground circuit.</li> <li>Verify cable integrity and assure it is seated correctly and has no signs of moisture or corrosion.</li> </ul>
117	4	ECAS Control Unit	Under-voltage or short to ground.	Cable may be defective.	<ul style="list-style-type: none"> <li>Verify the RSS ECU power connector is seated correctly and has no signs of moisture or corrosion.</li> <li>Verify correct power, ground at the main RSS ECU power connector and load test the power and ground circuit.</li> <li>Verify cable integrity and assure it is seated correctly and has no signs of moisture or corrosion.</li> </ul>
118	3	External Axle Load Sensor (axle c-d)	Over-voltage or short to supply.	Over-voltage or short circuit of the sensor cable detected.	<ul style="list-style-type: none"> <li>Verify the RSS ECU power connector is seated correctly and has no signs of moisture or corrosion.</li> <li>Verify correct power, ground at the main RSS ECU power connector and load test the power and ground circuit.</li> <li>Verify cable integrity and assure it is seated correctly and has no signs of moisture or corrosion.</li> </ul>
118	4	External Axle Load Sensor (axle c-d)	Under-voltage or short to ground.	Under-voltage or short circuit of the sensor cable detected.	<ul style="list-style-type: none"> <li>Verify the RSS ECU power connector is seated correctly and has no signs of moisture or corrosion.</li> <li>Verify correct power, ground at the main RSS ECU power connector and load test the power and ground circuit.</li> <li>Verify cable integrity and assure it is seated correctly and has no signs of moisture or corrosion.</li> </ul>
118	5	External Axle Load Sensor (axle c-d)	Open circuit.	Open circuit (cable break) of the sensor cable detected.	<ul style="list-style-type: none"> <li>Verify the RSS ECU power connector is seated correctly and has no signs of moisture or corrosion.</li> <li>Verify correct power, ground at the main RSS ECU power connector and load test the power and ground circuit.</li> <li>Verify cable integrity and assure it is seated correctly and has no signs of moisture or corrosion.</li> </ul>



SID	FMI	Suspect Component and Location	Fault Description (FMI)	Cause	Repair Information
118	12	External Axle Load Sensor (axle c-d)	Support bellows - low pressure.	Air suspension support bellows too low while driving.	<ul style="list-style-type: none"> <li>Verify the RSS ECU power connector is seated correctly and has no signs of moisture or corrosion.</li> <li>Verify correct power, ground at the main RSS ECU power connector and load test the power and ground circuit.</li> <li>Check bellows pressure, connectors and fittings.</li> </ul>
119	3	External Axle Load Sensor (axle e-f)	Over-voltage or short to supply.	Over-voltage or short circuit of the sensor cable detected.	<ul style="list-style-type: none"> <li>Verify the RSS ECU power connector is seated correctly and has no signs of moisture or corrosion.</li> <li>Verify correct power, ground at the main RSS ECU power connector and load test the power and ground circuit.</li> <li>Verify cable integrity and assure it is seated correctly and has no signs of moisture or corrosion.</li> </ul>
119	4	External Axle Load Sensor (axle e-f)	Under-voltage or short to ground.	Under-voltage or short circuit of the sensor cable detected.	<ul style="list-style-type: none"> <li>Verify the RSS ECU power connector is seated correctly and has no signs of moisture or corrosion.</li> <li>Verify correct power, ground at the main RSS ECU power connector and load test the power and ground circuit.</li> <li>Verify cable integrity and assure it is seated correctly and has no signs of moisture or corrosion.</li> </ul>
119	5	External Axle Load Sensor (axle e-f)	Open circuit.	Open circuit (cable break) of the sensor cable detected.	<ul style="list-style-type: none"> <li>Verify the RSS ECU power connector is seated correctly and has no signs of moisture or corrosion.</li> <li>Verify correct power, ground at the main RSS ECU power connector and load test the power and ground circuit.</li> <li>Verify cable integrity and assure it is seated correctly and has no signs of moisture or corrosion.</li> </ul>
119	12	External Axle Load Sensor (axle e-f)	Support bellows - low pressure.	Air suspension support bellows too low while driving.	<ul style="list-style-type: none"> <li>Verify the RSS ECU power connector is seated correctly and has no signs of moisture or corrosion.</li> <li>Verify correct power, ground at the main RSS ECU power connector and load test the power and ground circuit.</li> <li>Check bellows pressure, connectors and fittings.</li> </ul>
120	2	Axle Load Distance Sensor (axle c-d)	Irregular or incorrect data.	Axle load distance sensor linkage out of range or broken.	<ul style="list-style-type: none"> <li>Verify the RSS ECU power connector is seated correctly and has no signs of moisture or corrosion.</li> <li>Verify correct power, ground at the main RSS ECU power connector and load test the power and ground circuit.</li> <li>Verify cable integrity and assure it is seated correctly and has no signs of moisture or corrosion.</li> </ul>

SID	FMI	Suspect Component and Location	Fault Description (FMI)	Cause	Repair Information
120	3	Axle Load Distance Sensor (axle c-d)	Over-voltage or short to supply.	Over-voltage or short circuit of the sensor cable detected.	<ul style="list-style-type: none"> <li>• Verify the RSS ECU power connector is seated correctly and has no signs of moisture or corrosion.</li> <li>• Verify correct power, ground at the main RSS ECU power connector and load test the power and ground circuit.</li> <li>• Verify cable integrity and assure it is seated correctly and has no signs of moisture or corrosion.</li> </ul>
120	4	Axle Load Distance Sensor (axle c-d)	Under-voltage or short to ground.	Under-voltage or short circuit of the sensor cable detected.	<ul style="list-style-type: none"> <li>• Verify the RSS ECU power connector is seated correctly and has no signs of moisture or corrosion.</li> <li>• Verify correct power, ground at the main RSS ECU power connector and load test the power and ground circuit.</li> <li>• Verify cable integrity and assure it is seated correctly and has no signs of moisture or corrosion.</li> </ul>
120	5	Axle Load Distance Sensor (axle c-d)	Open circuit.	Open circuit (cable break) of the sensor cable detected.	<ul style="list-style-type: none"> <li>• Verify the RSS ECU power connector is seated correctly and has no signs of moisture or corrosion.</li> <li>• Verify correct power, ground at the main RSS ECU power connector and load test the power and ground circuit.</li> <li>• Verify cable integrity and assure it is seated correctly and has no signs of moisture or corrosion.</li> </ul>
120	12	Axle Load Distance Sensor (axle c-d)	Axle load distance sensor.	Distance sensor value too low while driving.	<ul style="list-style-type: none"> <li>• Verify correct installation and inspect sensor.</li> <li>• Verify the RSS ECU power connector is seated correctly and has no signs of moisture or corrosion.</li> <li>• Verify correct power, ground at the main RSS ECU power connector and load test the power and ground circuit.</li> <li>• Verify cable integrity and assure it is seated correctly and has no signs of moisture or corrosion.</li> <li>• Recalibrate distance sensor with TOOLBOX™ Software.</li> <li>• Distance sensor resistance is 88±5 ohms.</li> </ul>
120	13	Axle Load Distance Sensor (axle c-d)	Characteristic curve error.	Axle load distance sensor linkage out of range or broken.	<ul style="list-style-type: none"> <li>• Verify correct installation and inspect sensor.</li> <li>• Inspect sensor linkage and verify correct calibration.</li> <li>• Verify the RSS ECU power connector is seated correctly and has no signs of moisture or corrosion.</li> <li>• Verify correct power, ground at the main RSS ECU power connector and load test the power and ground circuit.</li> <li>• Verify cable integrity and assure it is seated correctly and has no signs of moisture or corrosion.</li> </ul>

# Diagnostics

SID	FMI	Suspect Component and Location	Fault Description (FMI)	Cause	Repair Information
121	2	Axle Load Distance Sensor (axle e-f)	Irregular or incorrect data.	Axle load distance sensor linkage out of range or broken.	<ul style="list-style-type: none"> <li>• Verify correct installation and inspect sensor.</li> <li>• Verify the RSS ECU power connector is seated correctly and has no signs of moisture or corrosion.</li> <li>• Verify correct power, ground at the main RSS ECU power connector and load test the power and ground circuit.</li> <li>• Verify cable integrity and assure it is seated correctly and has no signs of moisture or corrosion.</li> </ul>
121	3	Axle Load Distance Sensor (axle e-f)	Over-voltage or short to supply.	Over-voltage or short circuit of the sensor cable detected.	<ul style="list-style-type: none"> <li>• Verify correct installation and inspect sensor.</li> <li>• Verify the RSS ECU power connector is seated correctly and has no signs of moisture or corrosion.</li> <li>• Verify correct power, ground at the main RSS ECU power connector and load test the power and ground circuit.</li> <li>• Verify cable integrity and assure it is seated correctly and has no signs of moisture or corrosion.</li> </ul>
121	4	Axle Load Distance Sensor (axle e-f)	Under-voltage or short to ground.	Under-voltage or short circuit of the sensor cable detected.	<ul style="list-style-type: none"> <li>• Verify correct installation and inspect sensor.</li> <li>• Verify the RSS ECU power connector is seated correctly and has no signs of moisture or corrosion.</li> <li>• Verify correct power, ground at the main RSS ECU power connector and load test the power and ground circuit.</li> <li>• Verify cable integrity and assure it is seated correctly and has no signs of moisture or corrosion.</li> </ul>
121	5	Axle Load Distance Sensor (axle e-f)	Open circuit.	Open circuit (cable break) of the sensor cable detected.	<ul style="list-style-type: none"> <li>• Verify correct installation and inspect sensor.</li> <li>• Verify the RSS ECU power connector is seated correctly and has no signs of moisture or corrosion.</li> <li>• Verify correct power, ground at the main RSS ECU power connector and load test the power and ground circuit.</li> <li>• Verify cable integrity and assure it is seated correctly and has no signs of moisture or corrosion.</li> </ul>
121	12	Axle Load Distance Sensor (axle e-f)	Axle load distance sensor.	Distance sensor value too low while driving.	<ul style="list-style-type: none"> <li>• Verify correct installation and inspect sensor.</li> <li>• Verify the RSS ECU power connector is seated correctly and has no signs of moisture or corrosion.</li> <li>• Verify correct power, ground at the main RSS ECU power connector and load test the power and ground circuit.</li> <li>• Verify cable integrity and assure it is seated correctly and has no signs of moisture or corrosion.</li> </ul>

SID	FMI	Suspect Component and Location	Fault Description (FMI)	Cause	Repair Information
121	13	Axle Load Distance Sensor (axle e-f)	Characteristic curve error.	Axle load distance sensor linkage out of range or broken.	<ul style="list-style-type: none"> <li>• Verify correct installation and inspect sensor.</li> <li>• Inspect sensor linkage and verify correct calibration.</li> <li>• Verify the RSS ECU power connector is seated correctly and has no signs of moisture or corrosion.</li> <li>• Verify correct power, ground at the main RSS ECU power connector and load test the power and ground circuit.</li> <li>• Verify cable integrity and assure it is seated correctly and has no signs of moisture or corrosion.</li> </ul>
122	12	Freely Programmable Function 3	Fault detected.	ECU has detected a fault in the freely programmable function.	<ul style="list-style-type: none"> <li>• Verify correct installation and inspect sensor if related to the programmed function.</li> <li>• Verify the RSS ECU power connector is seated correctly and has no signs of moisture or corrosion.</li> <li>• Verify correct power, ground at the main RSS ECU power connector and load test the power and ground circuit.</li> <li>• Verify cable integrity and assure it is seated correctly and has no signs of moisture or corrosion.</li> </ul>
123	12	Freely Programmable Function 2	Fault detected.	ECU has detected a fault in the freely programmable function.	<ul style="list-style-type: none"> <li>• Verify correct installation and inspect sensor if related to the programmed function.</li> <li>• Verify the RSS ECU power connector is seated correctly and has no signs of moisture or corrosion.</li> <li>• Verify correct power, ground at the main RSS ECU power connector and load test the power and ground circuit.</li> <li>• Verify cable integrity and assure it is seated correctly and has no signs of moisture or corrosion.</li> </ul>
124	12	Freely Programmable Function 1	Fault detected.	ECU has detected a fault in the freely programmable function.	<ul style="list-style-type: none"> <li>• Verify correct installation and inspect sensor if related to the programmed function.</li> <li>• Verify the RSS ECU power connector is seated correctly and has no signs of moisture or corrosion.</li> <li>• Verify correct power, ground at the main RSS ECU power connector and load test the power and ground circuit.</li> <li>• Verify cable integrity and assure it is seated correctly and has no signs of moisture or corrosion.</li> </ul>
125	3	Unloading Level Switch	Short circuit to supply.	ECU has detected a short circuit of the unloading level switch cable to supply.	<ul style="list-style-type: none"> <li>• Verify correct installation and inspect switch.</li> <li>• Verify the RSS ECU power connector is seated correctly and has no signs of moisture or corrosion.</li> <li>• Verify correct power, ground at the main RSS ECU power connector and load test the power and ground circuit.</li> <li>• Verify cable integrity and assure it is seated correctly and has no signs of moisture or corrosion.</li> </ul>

SID	FMI	Suspect Component and Location	Fault Description (FMI)	Cause	Repair Information
126	3	Speed Signal Output	Short circuit to supply.	The cable to the component on the speed output is shorted to supply voltage.	<ul style="list-style-type: none"> <li>• Verify correct installation speed signal component.</li> <li>• Verify the RSS ECU power connector is seated correctly and has no signs of moisture or corrosion.</li> <li>• Verify correct power, ground at the main RSS ECU power connector and load test the power and ground circuit.</li> <li>• Verify cable integrity and assure it is seated correctly and has no signs of moisture or corrosion.</li> </ul>
126	4	Speed Signal Output	Short circuit to ground.	The cable to the component on the speed output is shorted to ground.	<ul style="list-style-type: none"> <li>• Verify correct installation speed signal component.</li> <li>• Verify the RSS ECU power connector is seated correctly and has no signs of moisture or corrosion.</li> <li>• Verify correct power, ground at the main RSS ECU power connector and load test the power and ground circuit.</li> <li>• Verify cable integrity and assure it is seated correctly and has no signs of moisture or corrosion.</li> </ul>
126	5	Speed Signal Output	Speed output cable interruption.	The cable to the component on the speed output is not connected or broken.	<ul style="list-style-type: none"> <li>• Verify correct installation speed signal component.</li> <li>• Verify the RSS ECU power connector is seated correctly and has no signs of moisture or corrosion.</li> <li>• Verify correct power, ground at the main RSS ECU power connector and load test the power and ground circuit.</li> <li>• Verify cable integrity and assure it is seated correctly and has no signs of moisture or corrosion.</li> </ul>
127	2	Distance Sensor 2 (axle e-f)	Data is irregular or incorrect.	The data from the sensor is not possible.	<ul style="list-style-type: none"> <li>• Verify correct installation and inspect sensor.</li> <li>• Verify the RSS ECU power connector is seated correctly and has no signs of moisture or corrosion.</li> <li>• Verify correct power, ground at the main RSS ECU power connector and load test the power and ground circuit.</li> <li>• Verify cable integrity and assure it is seated correctly and has no signs of moisture or corrosion.</li> </ul>
127	3	Distance Sensor 2 (axle e-f)	Short circuit to supply.	The cable to the distance sensor is shorted to supply voltage.	<ul style="list-style-type: none"> <li>• Verify correct installation and inspect sensor.</li> <li>• Verify the RSS ECU power connector is seated correctly and has no signs of moisture or corrosion.</li> <li>• Verify correct power, ground at the main RSS ECU power connector and load test the power and ground circuit.</li> <li>• Verify cable integrity and assure it is seated correctly and has no signs of moisture or corrosion.</li> </ul>

SID	FMI	Suspect Component and Location	Fault Description (FMI)	Cause	Repair Information
127	4	Distance Sensor 2 (axle e-f)	Short circuit to ground.	The cable to the distance sensor is shorted to ground.	<ul style="list-style-type: none"> <li>• Verify correct installation and inspect sensor.</li> <li>• Verify the RSS ECU power connector is seated correctly and has no signs of moisture or corrosion.</li> <li>• Verify correct power, ground at the main RSS ECU power connector and load test the power and ground circuit.</li> <li>• Verify cable integrity and assure it is seated correctly and has no signs of moisture or corrosion.</li> </ul>
127	5	Distance Sensor 2 (axle e-f)	Distance sensor cable interruption.	The cable to the distance sensor is not connected or broken.	<ul style="list-style-type: none"> <li>• Verify correct installation and inspect sensor.</li> <li>• Verify the RSS ECU power connector is seated correctly and has no signs of moisture or corrosion.</li> <li>• Verify correct power, ground at the main RSS ECU power connector and load test the power and ground circuit.</li> <li>• Verify cable integrity and assure it is seated correctly and has no signs of moisture or corrosion.</li> </ul>
128	2	Distance Sensor 1 (axle c-d)	Data is irregular or incorrect.	The data from the sensor is not possible.	<ul style="list-style-type: none"> <li>• Verify correct installation and inspect sensor.</li> <li>• Verify the RSS ECU power connector is seated correctly and has no signs of moisture or corrosion.</li> <li>• Verify correct power, ground at the main RSS ECU power connector and load test the power and ground circuit.</li> <li>• Verify cable integrity and assure it is seated correctly and has no signs of moisture or corrosion.</li> </ul>
128	3	Distance Sensor 1 (axle c-d)	Short circuit to supply.	The cable to the distance sensor is shorted to supply voltage.	<ul style="list-style-type: none"> <li>• Verify correct installation and inspect sensor.</li> <li>• Verify the RSS ECU power connector is seated correctly and has no signs of moisture or corrosion.</li> <li>• Verify correct power, ground at the main RSS ECU power connector and load test the power and ground circuit.</li> <li>• Verify cable integrity and assure it is seated correctly and has no signs of moisture or corrosion.</li> </ul>
128	4	Distance Sensor 1 (axle c-d)	Short circuit to ground.	The cable to the distance sensor is shorted to ground.	<ul style="list-style-type: none"> <li>• Verify correct installation and inspect sensor.</li> <li>• Verify the RSS ECU power connector is seated correctly and has no signs of moisture or corrosion.</li> <li>• Verify correct power, ground at the main RSS ECU power connector and load test the power and ground circuit.</li> <li>• Verify cable integrity and assure it is seated correctly and has no signs of moisture or corrosion.</li> </ul>

SID	FMI	Suspect Component and Location	Fault Description (FMI)	Cause	Repair Information
128	5	Distance Sensor 1 (axle c-d)	Distance sensor cable interruption.	The cable to the distance sensor is not connected or broken.	<ul style="list-style-type: none"> <li>• Verify correct installation and inspect sensor.</li> <li>• Verify the RSS ECU power connector is seated correctly and has no signs of moisture or corrosion.</li> <li>• Verify correct power, ground at the main RSS ECU power connector and load test the power and ground circuit.</li> <li>• Verify cable integrity and assure it is seated correctly and has no signs of moisture or corrosion.</li> </ul>
129	3	ECAS Valve Block	Short circuit to supply.	The cable to the ECAS valve block is shorted to supply voltage.	<ul style="list-style-type: none"> <li>• Verify correct installation.</li> <li>• Verify the RSS ECU power connector is seated correctly and has no signs of moisture or corrosion.</li> <li>• Verify correct power, ground at the main RSS ECU power connector and load test the power and ground circuit.</li> <li>• Verify cable integrity and assure it is seated correctly and has no signs of moisture or corrosion.</li> </ul>
129	4	ECAS Valve Block	Short circuit to ground.	The cable to the ECAS valve block is shorted to ground.	<ul style="list-style-type: none"> <li>• Verify correct installation.</li> <li>• Verify the RSS ECU power connector is seated correctly and has no signs of moisture or corrosion.</li> <li>• Verify correct power, ground at the main RSS ECU power connector and load test the power and ground circuit.</li> <li>• Verify cable integrity and assure it is seated correctly and has no signs of moisture or corrosion.</li> </ul>
129	5	ECAS Valve Block	Supply cable interruption.	The cable to the ECAS valve block is not connected or broken.	<ul style="list-style-type: none"> <li>• Verify correct installation.</li> <li>• Verify the RSS ECU power connector is seated correctly and has no signs of moisture or corrosion.</li> <li>• Verify correct power, ground at the main RSS ECU power connector and load test the power and ground circuit.</li> <li>• Verify cable integrity and assure it is seated correctly and has no signs of moisture or corrosion.</li> </ul>
130	3	Steady Positive Voltage 2 Output	Over-voltage or short to supply.	The cable to the steady positive voltage output is shorted to supply.	<ul style="list-style-type: none"> <li>• Verify correct installation.</li> <li>• Verify the RSS ECU power connector is seated correctly and has no signs of moisture or corrosion.</li> <li>• Verify correct power, ground at the main RSS ECU power connector and load test the power and ground circuit.</li> <li>• Verify cable integrity and assure it is seated correctly and has no signs of moisture or corrosion.</li> </ul>

SID	FMI	Suspect Component and Location	Fault Description (FMI)	Cause	Repair Information
130	4	Steady Positive Voltage 2 Output	Under-voltage or short to ground.	The cable to the steady positive voltage output is shorted to ground.	<ul style="list-style-type: none"> <li>• Verify correct installation.</li> <li>• Verify the RSS ECU power connector is seated correctly and has no signs of moisture or corrosion.</li> <li>• Verify correct power, ground at the main RSS ECU power connector and load test the power and ground circuit.</li> <li>• Verify cable integrity and assure it is seated correctly and has no signs of moisture or corrosion.</li> </ul>
130	5	Steady Positive Voltage 2 Output	Output cable interruption.	The cable to the steady positive voltage is not connected or broken.	<ul style="list-style-type: none"> <li>• Verify correct installation.</li> <li>• Verify the RSS ECU power connector is seated correctly and has no signs of moisture or corrosion.</li> <li>• Verify correct power, ground at the main RSS ECU power connector and load test the power and ground circuit.</li> <li>• Verify cable integrity and assure it is seated correctly and has no signs of moisture or corrosion.</li> </ul>
131	3	Steady Positive Voltage 1 Output	Over-voltage or short to supply.	The cable to the steady positive voltage output is shorted to supply.	<ul style="list-style-type: none"> <li>• Verify correct installation.</li> <li>• Verify the RSS ECU power connector is seated correctly and has no signs of moisture or corrosion.</li> <li>• Verify correct power, ground at the main RSS ECU power connector and load test the power and ground circuit.</li> <li>• Verify cable integrity and assure it is seated correctly and has no signs of moisture or corrosion.</li> </ul>
131	4	Steady Positive Voltage 1 Output	Under-voltage or short to ground.	The cable to the steady positive voltage output is shorted to ground.	<ul style="list-style-type: none"> <li>• Verify correct installation.</li> <li>• Verify the RSS ECU power connector is seated correctly and has no signs of moisture or corrosion.</li> <li>• Verify correct power, ground at the main RSS ECU power connector and load test the power and ground circuit.</li> <li>• Verify cable integrity and assure it is seated correctly and has no signs of moisture or corrosion.</li> </ul>
131	5	Steady Positive Voltage 1 Output	Output cable interruption.	The cable to the steady positive voltage is not connected or broken.	<ul style="list-style-type: none"> <li>• Verify correct installation.</li> <li>• Verify the RSS ECU power connector is seated correctly and has no signs of moisture or corrosion.</li> <li>• Verify correct power, ground at the main RSS ECU power connector and load test the power and ground circuit.</li> <li>• Verify cable integrity and assure it is seated correctly and has no signs of moisture or corrosion.</li> </ul>



# Diagnostics

SID	FMI	Suspect Component and Location	Fault Description (FMI)	Cause	Repair Information
132	3	RSS Active Signal Output	Over-voltage or short to supply.	The cable to the RSS active signal is shorted to supply.	<ul style="list-style-type: none"> <li>• Verify correct installation.</li> <li>• Verify the RSS ECU power connector is seated correctly and has no signs of moisture or corrosion.</li> <li>• Verify correct power, ground at the main RSS ECU power connector and load test the power and ground circuit.</li> <li>• Verify cable integrity and assure it is seated correctly and has no signs of moisture or corrosion.</li> </ul>
132	4	RSS Active Signal Output	Under-voltage or short to ground.	The cable to the RSS active signal output is shorted to ground.	<ul style="list-style-type: none"> <li>• Verify correct installation.</li> <li>• Verify the RSS ECU power connector is seated correctly and has no signs of moisture or corrosion.</li> <li>• Verify correct power, ground at the main RSS ECU power connector and load test the power and ground circuit.</li> <li>• Verify cable integrity and assure it is seated correctly and has no signs of moisture or corrosion.</li> </ul>
132	5	RSS Active Signal Output	Output cable interruption.	The cable to the RSS active signal is not connected or broken.	<ul style="list-style-type: none"> <li>• Verify correct installation.</li> <li>• Verify the RSS ECU power connector is seated correctly and has no signs of moisture or corrosion.</li> <li>• Verify correct power, ground at the main RSS ECU power connector and load test the power and ground circuit.</li> <li>• Verify cable integrity and assure it is seated correctly and has no signs of moisture or corrosion.</li> </ul>
133	3	ABS Active Signal Output	Over-voltage or short to supply.	The cable to the ABS active signal is shorted to supply.	<ul style="list-style-type: none"> <li>• Verify correct installation.</li> <li>• Verify the RSS ECU power connector is seated correctly and has no signs of moisture or corrosion.</li> <li>• Verify correct power, ground at the main RSS ECU power connector and load test the power and ground circuit.</li> <li>• Verify cable integrity and assure it is seated correctly and has no signs of moisture or corrosion.</li> </ul>
133	4	ABS Active Signal Output	Under-voltage or short to ground.	The cable to the ABS active signal output is shorted to ground.	<ul style="list-style-type: none"> <li>• Verify correct installation.</li> <li>• Verify the RSS ECU power connector is seated correctly and has no signs of moisture or corrosion.</li> <li>• Verify correct power, ground at the main RSS ECU power connector and load test the power and ground circuit.</li> <li>• Verify cable integrity and assure it is seated correctly and has no signs of moisture or corrosion.</li> </ul>

SID	FMI	Suspect Component and Location	Fault Description (FMI)	Cause	Repair Information
133	5	ABS Active Signal Output	Output cable interruption.	The cable to the ABS active signal is not connected or broken.	<ul style="list-style-type: none"> <li>• Verify correct installation.</li> <li>• Verify the RSS ECU power connector is seated correctly and has no signs of moisture or corrosion.</li> <li>• Verify correct power, ground at the main RSS ECU power connector and load test the power and ground circuit.</li> <li>• Verify cable integrity and assure it is seated correctly and has no signs of moisture or corrosion.</li> </ul>
134	3	Road Finisher Brake	Over-voltage or short to supply.	The cable to the road finisher brake is shorted to supply.	<ul style="list-style-type: none"> <li>• Verify correct installation.</li> <li>• Verify the RSS ECU power connector is seated correctly and has no signs of moisture or corrosion.</li> <li>• Verify correct power, ground at the main RSS ECU power connector and load test the power and ground circuit.</li> <li>• Verify cable integrity and assure it is seated correctly and has no signs of moisture or corrosion.</li> </ul>
137	3	Speed Switch 2 (ISS 2)	Over-voltage or short to supply.	The cable to the speed switch is shorted to supply.	<ul style="list-style-type: none"> <li>• Verify correct installation.</li> <li>• Verify the RSS ECU power connector is seated correctly and has no signs of moisture or corrosion.</li> <li>• Verify correct power, ground at the main RSS ECU power connector and load test the power and ground circuit.</li> <li>• Verify cable integrity and assure it is seated correctly and has no signs of moisture or corrosion.</li> </ul>
137	4	Speed Switch 2 (ISS 2)	Under-voltage or short to ground.	The cable to the speed switch is shorted to ground.	<ul style="list-style-type: none"> <li>• Verify correct installation.</li> <li>• Verify the RSS ECU power connector is seated correctly and has no signs of moisture or corrosion.</li> <li>• Verify correct power, ground at the main RSS ECU power connector and load test the power and ground circuit.</li> <li>• Verify cable integrity and assure it is seated correctly and has no signs of moisture or corrosion.</li> </ul>
137	5	Speed Switch 2 (ISS 2)	Output cable interruption.	The cable to the speed switch is not connected or broken.	<ul style="list-style-type: none"> <li>• Verify correct installation.</li> <li>• Verify the RSS ECU power connector is seated correctly and has no signs of moisture or corrosion.</li> <li>• Verify correct power, ground at the main RSS ECU power connector and load test the power and ground circuit.</li> <li>• Verify cable integrity and assure it is seated correctly and has no signs of moisture or corrosion.</li> </ul>

# Diagnostics

SID	FMI	Suspect Component and Location	Fault Description (FMI)	Cause	Repair Information
138	3	Speed Switch 1 (ISS 1)	Over-voltage or short to supply.	The cable to the speed switch is shorted to supply.	<ul style="list-style-type: none"> <li>• Verify correct installation.</li> <li>• Verify the RSS ECU power connector is seated correctly and has no signs of moisture or corrosion.</li> <li>• Verify correct power, ground at the main RSS ECU power connector and load test the power and ground circuit.</li> <li>• Verify cable integrity and assure it is seated correctly and has no signs of moisture or corrosion.</li> </ul>
138	4	Speed Switch 1 (ISS 1)	Under-voltage or short to ground.	The cable to the speed switch is shorted to ground.	<ul style="list-style-type: none"> <li>• Verify correct installation.</li> <li>• Verify the RSS ECU power connector is seated correctly and has no signs of moisture or corrosion.</li> <li>• Verify correct power, ground at the main RSS ECU power connector and load test the power and ground circuit.</li> <li>• Verify cable integrity and assure it is seated correctly and has no signs of moisture or corrosion.</li> </ul>
138	5	Speed Switch 1 (ISS 1)	Output cable interruption.	The cable to the speed switch is not connected or broken.	<ul style="list-style-type: none"> <li>• Verify correct installation.</li> <li>• Verify the RSS ECU power connector is seated correctly and has no signs of moisture or corrosion.</li> <li>• Verify correct power, ground at the main RSS ECU power connector and load test the power and ground circuit.</li> <li>• Verify cable integrity and assure it is seated correctly and has no signs of moisture or corrosion.</li> </ul>
139	3	Residual Pressure Valve (maneuver assistance)	Over-voltage or short to supply.	The cable to the residual pressure valve is shorted to supply.	<ul style="list-style-type: none"> <li>• Verify correct installation.</li> <li>• Verify the RSS ECU power connector is seated correctly and has no signs of moisture or corrosion.</li> <li>• Verify correct power, ground at the main RSS ECU power connector and load test the power and ground circuit.</li> <li>• Verify cable integrity and assure it is seated correctly and has no signs of moisture or corrosion.</li> </ul>
139	4	Residual Pressure Valve (maneuver assistance)	Under-voltage or short to ground.	The cable to the residual pressure valve is shorted to ground.	<ul style="list-style-type: none"> <li>• Verify correct installation.</li> <li>• Verify the RSS ECU power connector is seated correctly and has no signs of moisture or corrosion.</li> <li>• Verify correct power, ground at the main RSS ECU power connector and load test the power and ground circuit.</li> <li>• Verify cable integrity and assure it is seated correctly and has no signs of moisture or corrosion.</li> </ul>

SID	FMI	Suspect Component and Location	Fault Description (FMI)	Cause	Repair Information
139	5	Residual Pressure Valve (maneuver assistance)	Output cable interruption.	The cable to the residual pressure valve is not connected or broken.	<ul style="list-style-type: none"> <li>• Verify correct installation.</li> <li>• Verify the RSS ECU power connector is seated correctly and has no signs of moisture or corrosion.</li> <li>• Verify correct power, ground at the main RSS ECU power connector and load test the power and ground circuit.</li> <li>• Verify cable integrity and assure it is seated correctly and has no signs of moisture or corrosion.</li> </ul>
140	3	Residual Pressure Valve (low speed traction control)	Over-voltage or short to supply.	The cable to the residual pressure valve is shorted to supply.	<ul style="list-style-type: none"> <li>• Verify correct installation.</li> <li>• Verify the RSS ECU power connector is seated correctly and has no signs of moisture or corrosion.</li> <li>• Verify correct power, ground at the main RSS ECU power connector and load test the power and ground circuit.</li> <li>• Verify cable integrity and assure it is seated correctly and has no signs of moisture or corrosion.</li> </ul>
140	4	Residual Pressure Valve (low speed traction control)	Under-voltage or short to ground.	The cable to the residual pressure valve is shorted to ground.	<ul style="list-style-type: none"> <li>• Verify correct installation.</li> <li>• Verify the RSS ECU power connector is seated correctly and has no signs of moisture or corrosion.</li> <li>• Verify correct power, ground at the main RSS ECU power connector and load test the power and ground circuit.</li> <li>• Verify cable integrity and assure it is seated correctly and has no signs of moisture or corrosion.</li> </ul>
140	5	Residual Pressure Valve (low speed traction control)	Output cable interruption.	The cable to the residual pressure valve is not connected or broken.	<ul style="list-style-type: none"> <li>• Verify correct installation.</li> <li>• Verify the RSS ECU power connector is seated correctly and has no signs of moisture or corrosion.</li> <li>• Verify correct power, ground at the main RSS ECU power connector and load test the power and ground circuit.</li> <li>• Verify cable integrity and assure it is seated correctly and has no signs of moisture or corrosion.</li> </ul>
141	3	Lifting Axle Valve 2	Over-voltage or short to supply.	The cable to the lifting axle valve is shorted to supply.	<ul style="list-style-type: none"> <li>• Verify correct installation.</li> <li>• Verify the RSS ECU power connector is seated correctly and has no signs of moisture or corrosion.</li> <li>• Verify correct power, ground at the main RSS ECU power connector and load test the power and ground circuit.</li> <li>• Verify cable integrity and assure it is seated correctly and has no signs of moisture or corrosion.</li> </ul>

SID	FMI	Suspect Component and Location	Fault Description (FMI)	Cause	Repair Information
141	4	Lifting Axle Valve 2	Under-voltage or short to ground.	The cable to the lifting axle valve is shorted to ground.	<ul style="list-style-type: none"> <li>• Verify correct installation.</li> <li>• Verify the RSS ECU power connector is seated correctly and has no signs of moisture or corrosion.</li> <li>• Verify correct power, ground at the main RSS ECU power connector and load test the power and ground circuit.</li> <li>• Verify cable integrity and assure it is seated correctly and has no signs of moisture or corrosion.</li> </ul>
141	5	Lifting Axle Valve 2	Output cable interruption.	The cable to the lifting axle valve is not connected or broken.	<ul style="list-style-type: none"> <li>• Verify correct installation.</li> <li>• Verify the RSS ECU power connector is seated correctly and has no signs of moisture or corrosion.</li> <li>• Verify correct power, ground at the main RSS ECU power connector and load test the power and ground circuit.</li> <li>• Verify cable integrity and assure it is seated correctly and has no signs of moisture or corrosion.</li> </ul>
142	3	Lifting Axle Valve 1	Over-voltage or short to supply.	The cable to the lifting axle valve is shorted to supply.	<ul style="list-style-type: none"> <li>• Verify correct installation.</li> <li>• Verify the RSS ECU power connector is seated correctly and has no signs of moisture or corrosion.</li> <li>• Verify correct power, ground at the main RSS ECU power connector and load test the power and ground circuit.</li> <li>• Verify cable integrity and assure it is seated correctly and has no signs of moisture or corrosion.</li> </ul>
142	4	Lifting Axle Valve 1	Under-voltage or short to ground.	The cable to the lifting axle valve is shorted to ground.	<ul style="list-style-type: none"> <li>• Verify correct installation.</li> <li>• Verify the RSS ECU power connector is seated correctly and has no signs of moisture or corrosion.</li> <li>• Verify correct power, ground at the main RSS ECU power connector and load test the power and ground circuit.</li> <li>• Verify cable integrity and assure it is seated correctly and has no signs of moisture or corrosion.</li> </ul>
142	5	Lifting Axle Valve 1	Output cable interruption.	The cable to the lifting axle valve is not connected or broken.	<ul style="list-style-type: none"> <li>• Verify correct installation.</li> <li>• Verify the RSS ECU power connector is seated correctly and has no signs of moisture or corrosion.</li> <li>• Verify correct power, ground at the main RSS ECU power connector and load test the power and ground circuit.</li> <li>• Verify cable integrity and assure it is seated correctly and has no signs of moisture or corrosion.</li> </ul>

SID	FMI	Suspect Component and Location	Fault Description (FMI)	Cause	Repair Information
143	15	Pneumatic Control Line	Residual pressure.	ECU has detected > 4 psi (0.3 bar) residual pressure in the yellow coupling head.	<ul style="list-style-type: none"> <li>Verify the RSS ECU power connector is seated correctly and has no signs of moisture or corrosion.</li> <li>Verify correct power, ground at the main RSS ECU power connector and load test the power and ground circuit.</li> <li>Verify lines are not crimped or bent.</li> <li>Verify cable integrity and assure it is seated correctly and has no signs of moisture or corrosion.</li> </ul>
144	0	Supply Pressure Sensor	Supply pressure exceeds 9.3 bar.	ECU has detected supply pressure greater than 135 psi (9.3 bar).	<ul style="list-style-type: none"> <li>Verify the RSS ECU power connector is seated correctly and has no signs of moisture or corrosion.</li> <li>Verify correct power, ground at the main RSS ECU power connector and load test the power and ground circuit.</li> <li>Verify lines are not crimped or bent.</li> <li>Verify cable integrity and assure it is seated correctly and has no signs of moisture or corrosion.</li> <li>Verify air output from towing vehicle is less than 135 psi.</li> </ul>
144	1	Supply Pressure Sensor	Value too low.	ECU has detected too low of supply pressure 65 psi (4.5 bar).	<ul style="list-style-type: none"> <li>Verify the RSS ECU power connector is seated correctly and has no signs of moisture or corrosion.</li> <li>Verify correct power, ground at the main RSS ECU power connector and load test the power and ground circuit.</li> <li>Verify lines are not crimped or bent.</li> <li>Verify cable integrity and assure it is seated correctly and has no signs of moisture or corrosion.</li> </ul>
144	3	Supply Pressure Sensor	Over-voltage/short to supply voltage.	ECU has detected an over-voltage/short to supply voltage condition.	<ul style="list-style-type: none"> <li>Verify the RSS ECU power connector is seated correctly and has no signs of moisture or corrosion.</li> <li>Verify correct power, ground at the main RSS ECU power connector and load test the power and ground circuit.</li> </ul>
144	4	Supply Pressure Sensor	Under-voltage/short to ground.	ECU has detected an under-voltage/short to ground condition.	<ul style="list-style-type: none"> <li>Verify the RSS ECU power connector is seated correctly and has no signs of moisture or corrosion.</li> <li>Verify correct power, ground at the main RSS ECU power connector and load test the power and ground circuit.</li> </ul>
144	12	Supply Pressure Sensor	Value too low.	ECU has detected too low of supply pressure 65 psi (4.5 bar).	<ul style="list-style-type: none"> <li>Verify the RSS ECU power connector is seated correctly and has no signs of moisture or corrosion.</li> <li>Verify correct power, ground at the main RSS ECU power connector and load test the power and ground circuit.</li> <li>Verify lines are not crimped or bent.</li> <li>Verify cable integrity and assure it is seated correctly and has no signs of moisture or corrosion.</li> </ul>

# Diagnostics

SID	FMI	Suspect Component and Location	Fault Description (FMI)	Cause	Repair Information
144	13	Supply Pressure Sensor	Supply pressure fell below 65 psi (4.5 bar) while driving.	ECU has detected a loss of pressure while driving.	<ul style="list-style-type: none"> <li>Verify the RSS ECU power connector is seated correctly and has no signs of moisture or corrosion.</li> <li>Verify correct power, ground at the main RSS ECU power connector and load test the power and ground circuit.</li> <li>Verify lines are not crimped or bent.</li> <li>Verify cable integrity and assure it is seated correctly and has no signs of moisture or corrosion.</li> </ul>
145	3	ELM (external)	Over-voltage or short to supply.	The cable to the ELM is shorted to supply.	<ul style="list-style-type: none"> <li>Verify correct installation.</li> <li>Verify the RSS ECU power connector is seated correctly and has no signs of moisture or corrosion.</li> <li>Verify correct power, ground at the main RSS ECU power connector and load test the power and ground circuit.</li> <li>Verify cable integrity and assure it is seated correctly and has no signs of moisture or corrosion.</li> </ul>
145	4	ELM (external)	Under-voltage or short to ground.	The cable to the ELM is shorted to ground.	<ul style="list-style-type: none"> <li>Verify correct installation.</li> <li>Verify the RSS ECU power connector is seated correctly and has no signs of moisture or corrosion.</li> <li>Verify correct power, ground at the main RSS ECU power connector and load test the power and ground circuit.</li> <li>Verify cable integrity and assure it is seated correctly and has no signs of moisture or corrosion.</li> </ul>
145	5	ELM (external)	Output cable interruption.	The cable to the ELM is not connected or broken.	<ul style="list-style-type: none"> <li>Verify correct installation.</li> <li>Verify the RSS ECU power connector is seated correctly and has no signs of moisture or corrosion.</li> <li>Verify correct power, ground at the main RSS ECU power connector and load test the power and ground circuit.</li> <li>Verify cable integrity and assure it is seated correctly and has no signs of moisture or corrosion.</li> </ul>
146	3	ECAS (external)	Over-voltage or short to supply.	The cable to the ECAS is shorted to supply.	<ul style="list-style-type: none"> <li>Verify correct installation.</li> <li>Verify the RSS ECU power connector is seated correctly and has no signs of moisture or corrosion.</li> <li>Verify correct power, ground at the main RSS ECU power connector and load test the power and ground circuit.</li> <li>Verify cable integrity and assure it is seated correctly and has no signs of moisture or corrosion.</li> </ul>

# Diagnostics

SID	FMI	Suspect Component and Location	Fault Description (FMI)	Cause	Repair Information
146	4	ECAS (external)	Under-voltage or short to ground.	The cable to the ECAS is shorted to ground.	<ul style="list-style-type: none"> <li>• Verify correct installation.</li> <li>• Verify the RSS ECU power connector is seated correctly and has no signs of moisture or corrosion.</li> <li>• Verify correct power, ground at the main RSS ECU power connector and load test the power and ground circuit.</li> <li>• Verify cable integrity and assure it is seated correctly and has no signs of moisture or corrosion.</li> </ul>
146	5	ECAS (external)	Output cable interruption.	The cable to the ECAS is not connected or broken.	<ul style="list-style-type: none"> <li>• Verify correct installation.</li> <li>• Verify the RSS ECU power connector is seated correctly and has no signs of moisture or corrosion.</li> <li>• Verify correct power, ground at the main RSS ECU power connector and load test the power and ground circuit.</li> <li>• Verify cable integrity and assure it is seated correctly and has no signs of moisture or corrosion.</li> </ul>
146	12	ECAS (external)	Communications interrupted.	ELM communications is not functioning.	<ul style="list-style-type: none"> <li>• Verify correct installation.</li> <li>• Verify the RSS ECU power connector is seated correctly and has no signs of moisture or corrosion.</li> <li>• Verify correct power, ground at the main RSS ECU power connector and load test the power and ground circuit.</li> <li>• Verify cable integrity and assure it is seated correctly and has no signs of moisture or corrosion.</li> </ul>
148	2	ECAS Internal Calibration	Data is irregular or incorrect.	ECAS data is irregular or incorrect. Calibration error.	<ul style="list-style-type: none"> <li>• Verify correct installation and calibrate distance sensors.</li> <li>• Verify the RSS ECU power connector is seated correctly and has no signs of moisture or corrosion.</li> <li>• Verify correct power, ground at the main RSS ECU power connector and load test the power and ground circuit.</li> <li>• Verify cable integrity and assure it is seated correctly and has no signs of moisture or corrosion.</li> </ul>
156	2	J2497 Datalink (PLC)	Data is irregular or incorrect.	Multiple causes.	<ul style="list-style-type: none"> <li>• Verify correct installation.</li> <li>• Verify the RSS ECU power connector is seated correctly and has no signs of moisture or corrosion.</li> <li>• Verify correct power, ground at the main RSS ECU power connector and load test the power and ground circuit.</li> <li>• Verify cable integrity and assure it is seated correctly and has no signs of moisture or corrosion.</li> </ul>



# Diagnostics

SID	FMI	Suspect Component and Location	Fault Description (FMI)	Cause	Repair Information
156	15	J2497 Datalink (PLC)	Residual pressure.	Multiple causes.	<ul style="list-style-type: none"> <li>Verify the RSS ECU power connector is seated correctly and has no signs of moisture or corrosion.</li> <li>Verify correct power, ground at the main RSS ECU power connector and load test the power and ground circuit.</li> <li>Verify lines are not crimped or bent.</li> <li>Verify cable integrity and assure it is seated correctly and has no signs of moisture or corrosion.</li> </ul>
220	9	Datalink (towing vehicle/trailer)	Communication error, interference.	Temporary reception interference. Disregard fault if no EBS towing vehicle.	<ul style="list-style-type: none"> <li>Verify correct installation.</li> <li>Verify the RSS ECU power connector is seated correctly and has no signs of moisture or corrosion.</li> <li>Verify correct power, ground at the main RSS ECU power connector and load test the power and ground circuit.</li> <li>Verify cable integrity and assure it is seated correctly and has no signs of moisture or corrosion.</li> </ul>
220	14	Datalink (towing vehicle/trailer)	Communication error.	Pins 6 or 7 of trailer connector interrupted or broken.	<ul style="list-style-type: none"> <li>Verify correct installation.</li> <li>Verify the RSS ECU power connector is seated correctly and has no signs of moisture or corrosion.</li> <li>Verify correct power, ground at the main RSS ECU power connector and load test the power and ground circuit.</li> <li>Verify cable integrity and assure it is seated correctly and has no signs of moisture or corrosion.</li> </ul>
250	15	J1708 Datalink	Residual pressure.	Unknown.	<ul style="list-style-type: none"> <li>Verify correct installation.</li> <li>Verify the RSS ECU power connector is seated correctly and has no signs of moisture or corrosion.</li> <li>Verify correct power, ground at the main RSS ECU power connector and load test the power and ground circuit.</li> <li>Verify cable integrity and assure it is seated correctly and has no signs of moisture or corrosion.</li> </ul>
251	1	Power Supply	Voltage too low.	An under-voltage has occurred.	<ul style="list-style-type: none"> <li>Verify correct installation.</li> <li>Verify the RSS ECU power connector is seated correctly and has no signs of moisture or corrosion.</li> <li>Verify correct power, ground at the main RSS ECU power connector and load test the power and ground circuit.</li> <li>Verify cable integrity and assure it is seated correctly and has no signs of moisture or corrosion.</li> </ul>

# Diagnostics

SID	FMI	Suspect Component and Location	Fault Description (FMI)	Cause	Repair Information
251	2	Power Supply	Data is irregular or incorrect.	Vehicle was operated via stop light power.	<ul style="list-style-type: none"> <li>• Verify correct installation.</li> <li>• Verify the RSS ECU power connector is seated correctly and has no signs of moisture or corrosion.</li> <li>• Verify correct power, ground at the main RSS ECU power connector and load test the power and ground circuit.</li> <li>• Verify cable integrity and assure it is seated correctly and has no signs of moisture or corrosion.</li> </ul>
251	3	Power Supply	Voltage too high.	Voltage from towing vehicle too high.	<ul style="list-style-type: none"> <li>• Verify correct installation.</li> <li>• Verify the RSS ECU power connector is seated correctly and has no signs of moisture or corrosion.</li> <li>• Verify correct power, ground at the main RSS ECU power connector and load test the power and ground circuit.</li> <li>• Verify cable integrity and assure it is seated correctly and has no signs of moisture or corrosion.</li> </ul>
251	4	Power Supply	Under-voltage or short to ground.	Voltage from towing vehicle is below 16 volts.	<ul style="list-style-type: none"> <li>• Verify correct installation.</li> <li>• Verify the RSS ECU power connector is seated correctly and has no signs of moisture or corrosion.</li> <li>• Verify correct power, ground at the main RSS ECU power connector and load test the power and ground circuit.</li> <li>• Verify cable integrity and assure it is seated correctly and has no signs of moisture or corrosion.</li> </ul>
251	5	Power Supply	Supply cable interruption.	The ground circuit is intermittent or broken.	<ul style="list-style-type: none"> <li>• Verify correct installation.</li> <li>• Verify the RSS ECU power connector is seated correctly and has no signs of moisture or corrosion.</li> <li>• Verify correct power, ground at the main RSS ECU power connector and load test the power and ground circuit.</li> <li>• Verify cable integrity and assure it is seated correctly and has no signs of moisture or corrosion.</li> </ul>
251	12	Power Supply	Under-voltage or short to ground (driving).	Under-voltage occurred while driving.	<ul style="list-style-type: none"> <li>• Verify correct installation.</li> <li>• Verify the RSS ECU power connector is seated correctly and has no signs of moisture or corrosion.</li> <li>• Verify correct power, ground at the main RSS ECU power connector and load test the power and ground circuit.</li> <li>• Verify cable integrity and assure it is seated correctly and has no signs of moisture or corrosion.</li> </ul>

SID	FMI	Suspect Component and Location	Fault Description (FMI)	Cause	Repair Information
253	2	Parameter Setting	Internal checksum error.	ECU internal checksum error.	<ul style="list-style-type: none"> <li>Verify correct installation and that the correct parameters are set for the application.</li> <li>Verify the RSS ECU power connector is seated correctly and has no signs of moisture or corrosion.</li> <li>Verify correct power, ground at the main RSS ECU power connector and load test the power and ground circuit.</li> <li>Verify cable integrity and assure it is seated correctly and has no signs of moisture or corrosion.</li> </ul>
253	12	Parameter Setting	Internal checksum error.	ECU detected checksum error.	<ul style="list-style-type: none"> <li>Verify correct installation and that the correct parameters are set for the application.</li> <li>Verify the RSS ECU power connector is seated correctly and has no signs of moisture or corrosion.</li> <li>Verify correct power, ground at the main RSS ECU power connector and load test the power and ground circuit.</li> <li>Verify cable integrity and assure it is seated correctly and has no signs of moisture or corrosion.</li> </ul>
253	14	Special Fault	Initialization start up error.	Vehicle has not been put into operation.	<ul style="list-style-type: none"> <li>Verify correct installation and run initial start routine.</li> <li>Verify the RSS ECU power connector is seated correctly and has no signs of moisture or corrosion.</li> <li>Verify correct power, ground at the main RSS ECU power connector and load test the power and ground circuit.</li> </ul>
254	3	Internal Error	Over-voltage or short to supply.	ECU has detected an over-voltage condition.	<ul style="list-style-type: none"> <li>Verify the RSS ECU power connector is seated correctly and has no signs of moisture or corrosion.</li> <li>Verify correct power, ground at the main RSS ECU power connector and load test the power and ground circuit.</li> </ul>
254	4	Internal Error	Under-voltage or short to ground.	ECU has detected an under-voltage condition.	<ul style="list-style-type: none"> <li>Verify the RSS ECU power connector is seated correctly and has no signs of moisture or corrosion.</li> <li>Verify correct power, ground at the main RSS ECU power connector and load test the power and ground circuit.</li> </ul>
254	11	Internal Error	Internal memory bit error.	ECU has detected an internal error on self check.	<ul style="list-style-type: none"> <li>Verify the RSS ECU power connector is seated correctly and has no signs of moisture or corrosion.</li> <li>Verify correct power, ground at the main RSS ECU power connector and load test the power and ground circuit.</li> </ul>
254	12	Internal Error	Internal error.	ECU has detected an internal error on self check.	<ul style="list-style-type: none"> <li>Verify the RSS ECU power connector is seated correctly and has no signs of moisture or corrosion.</li> <li>Verify correct power, ground at the main RSS ECU power connector and load test the power and ground circuit.</li> </ul>

# Diagnosics

SID	FMI	Suspect Component and Location	Fault Description (FMI)	Cause	Repair Information
142	3	Lifting Axle Valve 1	Over-voltage or short to supply.	The cable to the lifting axle valve is shorted to supply.	<ul style="list-style-type: none"> <li>• Verify correct installation.</li> <li>• Verify the RSS ECU power connector is seated correctly and has no signs of moisture or corrosion.</li> <li>• Verify correct power, ground at the main RSS ECU power connector and load test the power and ground circuit.</li> <li>• Verify cable integrity and assure it is seated correctly and has no signs of moisture or corrosion.</li> </ul>
142	4	Lifting Axle Valve 1	Under-voltage or short to ground.	The cable to the lifting axle valve is shorted to ground.	<ul style="list-style-type: none"> <li>• Verify correct installation.</li> <li>• Verify the RSS ECU power connector is seated correctly and has no signs of moisture or corrosion.</li> <li>• Verify correct power, ground at the main RSS ECU power connector and load test the power and ground circuit.</li> <li>• Verify cable integrity and assure it is seated correctly and has no signs of moisture or corrosion.</li> </ul>
142	5	Lifting Axle Valve 1	Output cable interruption.	The cable to the lifting axle valve is not connected or broken.	<ul style="list-style-type: none"> <li>• Verify correct installation.</li> <li>• Verify the RSS ECU power connector is seated correctly and has no signs of moisture or corrosion.</li> <li>• Verify correct power, ground at the main RSS ECU power connector and load test the power and ground circuit.</li> <li>• Verify cable integrity and assure it is seated correctly and has no signs of moisture or corrosion.</li> </ul>
143	15	Pneumatic Control Line	Residual pressure.	ECU has detected > 4 psi (0.3 bar) residual pressure in the yellow coupling head.	<ul style="list-style-type: none"> <li>• Verify the RSS ECU power connector is seated correctly and has no signs of moisture or corrosion.</li> <li>• Verify correct power, ground at the main RSS ECU power connector and load test the power and ground circuit.</li> <li>• Verify lines are not crimped or bent.</li> <li>• Verify cable integrity and assure it is seated correctly and has no signs of moisture or corrosion.</li> </ul>
144	0	Supply Pressure Sensor	Supply pressure exceeds 9.3 bar.	ECU has detected supply pressure greater than 135 psi (9.3 bar).	<ul style="list-style-type: none"> <li>• Verify the RSS ECU power connector is seated correctly and has no signs of moisture or corrosion.</li> <li>• Verify correct power, ground at the main RSS ECU power connector and load test the power and ground circuit.</li> <li>• Verify lines are not crimped or bent.</li> <li>• Verify cable integrity and assure it is seated correctly and has no signs of moisture or corrosion.</li> <li>• Verify air output from towing vehicle is less than 135 psi.</li> </ul>

4012964a

SID	FMI	Suspect Component and Location	Fault Description (FMI)	Cause	Repair Information
144	1	Supply Pressure Sensor	Value too low.	ECU has detected too low of supply pressure 65 psi (4.5 bar).	<ul style="list-style-type: none"> <li>Verify the RSS ECU power connector is seated correctly and has no signs of moisture or corrosion.</li> <li>Verify correct power, ground at the main RSS ECU power connector and load test the power and ground circuit.</li> <li>Verify lines are not crimped or bent.</li> <li>Verify cable integrity and assure it is seated correctly and has no signs of moisture or corrosion.</li> </ul>
144	3	Supply Pressure Sensor	Over-voltage/short to supply voltage.	ECU has detected an over-voltage/short to supply voltage condition.	<ul style="list-style-type: none"> <li>Verify the RSS ECU power connector is seated correctly and has no signs of moisture or corrosion.</li> <li>Verify correct power, ground at the main RSS ECU power connector and load test the power and ground circuit.</li> </ul>
144	4	Supply Pressure Sensor	Under-voltage/short to ground.	ECU has detected an under-voltage/short to ground condition.	<ul style="list-style-type: none"> <li>Verify the RSS ECU power connector is seated correctly and has no signs of moisture or corrosion.</li> <li>Verify correct power, ground at the main RSS ECU power connector and load test the power and ground circuit.</li> </ul>
144	12	Supply Pressure Sensor	Value too low.	ECU has detected too low of supply pressure 65 psi (4.5 bar).	<ul style="list-style-type: none"> <li>Verify the RSS ECU power connector is seated correctly and has no signs of moisture or corrosion.</li> <li>Verify correct power, ground at the main RSS ECU power connector and load test the power and ground circuit.</li> <li>Verify lines are not crimped or bent.</li> <li>Verify cable integrity and assure it is seated correctly and has no signs of moisture or corrosion.</li> </ul>
144	13	Supply Pressure Sensor	Supply pressure fell below 65 psi (4.5 bar) while driving.	ECU has detected a loss of pressure while driving.	<ul style="list-style-type: none"> <li>Verify the RSS ECU power connector is seated correctly and has no signs of moisture or corrosion.</li> <li>Verify correct power, ground at the main RSS ECU power connector and load test the power and ground circuit.</li> <li>Verify lines are not crimped or bent.</li> <li>Verify cable integrity and assure it is seated correctly and has no signs of moisture or corrosion.</li> </ul>
145	3	ELM (external)	Over-voltage or short to supply.	The cable to the ELM is shorted to supply.	<ul style="list-style-type: none"> <li>Verify correct installation.</li> <li>Verify the RSS ECU power connector is seated correctly and has no signs of moisture or corrosion.</li> <li>Verify correct power, ground at the main RSS ECU power connector and load test the power and ground circuit.</li> <li>Verify cable integrity and assure it is seated correctly and has no signs of moisture or corrosion.</li> </ul>
145	4	ELM (external)	Under-voltage or short to ground.	The cable to the ELM is shorted to ground.	<ul style="list-style-type: none"> <li>Verify correct installation.</li> <li>Verify the RSS ECU power connector is seated correctly and has no signs of moisture or corrosion.</li> <li>Verify correct power, ground at the main RSS ECU power connector and load test the power and ground circuit.</li> <li>Verify cable integrity and assure it is seated correctly and has no signs of moisture or corrosion.</li> </ul>

4012965a

# Diagnostics

SID	FMI	Suspect Component and Location	Fault Description (FMI)	Cause	Repair Information
145	5	ELM (external)	Output cable interruption.	The cable to the ELM is not connected or broken.	<ul style="list-style-type: none"> <li>Verify correct installation.</li> <li>Verify the RSS ECU power connector is seated correctly and has no signs of moisture or corrosion.</li> <li>Verify correct power, ground at the main RSS ECU power connector and load test the power and ground circuit.</li> <li>Verify cable integrity and assure it is seated correctly and has no signs of moisture or corrosion.</li> </ul>
146	3	ECAS (external)	Over-voltage or short to supply.	The cable to the ECAS is shorted to supply.	<ul style="list-style-type: none"> <li>Verify correct installation.</li> <li>Verify the RSS ECU power connector is seated correctly and has no signs of moisture or corrosion.</li> <li>Verify correct power, ground at the main RSS ECU power connector and load test the power and ground circuit.</li> <li>Verify cable integrity and assure it is seated correctly and has no signs of moisture or corrosion.</li> </ul>
146	4	ECAS (external)	Under-voltage or short to ground.	The cable to the ECAS is shorted to ground.	<ul style="list-style-type: none"> <li>Verify correct installation.</li> <li>Verify the RSS ECU power connector is seated correctly and has no signs of moisture or corrosion.</li> <li>Verify correct power, ground at the main RSS ECU power connector and load test the power and ground circuit.</li> <li>Verify cable integrity and assure it is seated correctly and has no signs of moisture or corrosion.</li> </ul>
146	5	ECAS (external)	Output cable interruption.	The cable to the ECAS is not connected or broken.	<ul style="list-style-type: none"> <li>Verify correct installation.</li> <li>Verify the RSS ECU power connector is seated correctly and has no signs of moisture or corrosion.</li> <li>Verify correct power, ground at the main RSS ECU power connector and load test the power and ground circuit.</li> <li>Verify cable integrity and assure it is seated correctly and has no signs of moisture or corrosion.</li> </ul>
146	12	ECAS (external)	Communications interrupted.	ELM communications is not functioning.	<ul style="list-style-type: none"> <li>Verify correct installation.</li> <li>Verify the RSS ECU power connector is seated correctly and has no signs of moisture or corrosion.</li> <li>Verify correct power, ground at the main RSS ECU power connector and load test the power and ground circuit.</li> <li>Verify cable integrity and assure it is seated correctly and has no signs of moisture or corrosion.</li> </ul>
148	2	ECAS Internal Calibration	Data is irregular or incorrect.	ECAS data is irregular or incorrect. Calibration error.	<ul style="list-style-type: none"> <li>Verify correct installation and calibrate distance sensors.</li> <li>Verify the RSS ECU power connector is seated correctly and has no signs of moisture or corrosion.</li> <li>Verify correct power, ground at the main RSS ECU power connector and load test the power and ground circuit.</li> <li>Verify cable integrity and assure it is seated correctly and has no signs of moisture or corrosion.</li> </ul>

4012966a

# Diagnostics

SID	FMI	Suspect Component and Location	Fault Description (FMI)	Cause	Repair Information
156	2	J2497 Datalink (PLC)	Data is irregular or incorrect.	Multiple causes.	<ul style="list-style-type: none"> <li>Verify correct installation.</li> <li>Verify the RSS ECU power connector is seated correctly and has no signs of moisture or corrosion.</li> <li>Verify correct power, ground at the main RSS ECU power connector and load test the power and ground circuit.</li> <li>Verify cable integrity and assure it is seated correctly and has no signs of moisture or corrosion.</li> </ul>
156	15	J2497 Datalink (PLC)	Residual pressure.	Multiple causes.	<ul style="list-style-type: none"> <li>Verify the RSS ECU power connector is seated correctly and has no signs of moisture or corrosion.</li> <li>Verify correct power, ground at the main RSS ECU power connector and load test the power and ground circuit.</li> <li>Verify lines are not crimped or bent.</li> <li>Verify cable integrity and assure it is seated correctly and has no signs of moisture or corrosion.</li> </ul>
220	9	Datalink (towing vehicle/trailer)	Communication error, interference.	Temporary reception interference. Disregard fault if no EBS towing vehicle.	<ul style="list-style-type: none"> <li>Verify correct installation.</li> <li>Verify the RSS ECU power connector is seated correctly and has no signs of moisture or corrosion.</li> <li>Verify correct power, ground at the main RSS ECU power connector and load test the power and ground circuit.</li> <li>Verify cable integrity and assure it is seated correctly and has no signs of moisture or corrosion.</li> </ul>
220	14	Datalink (towing vehicle/trailer)	Communication error.	Pins 6 or 7 of trailer connector interrupted or broken.	<ul style="list-style-type: none"> <li>Verify correct installation.</li> <li>Verify the RSS ECU power connector is seated correctly and has no signs of moisture or corrosion.</li> <li>Verify correct power, ground at the main RSS ECU power connector and load test the power and ground circuit.</li> <li>Verify cable integrity and assure it is seated correctly and has no signs of moisture or corrosion.</li> </ul>
250	15	J1708 Datalink	Residual pressure.	Unknown.	<ul style="list-style-type: none"> <li>Verify correct installation.</li> <li>Verify the RSS ECU power connector is seated correctly and has no signs of moisture or corrosion.</li> <li>Verify correct power, ground at the main RSS ECU power connector and load test the power and ground circuit.</li> <li>Verify cable integrity and assure it is seated correctly and has no signs of moisture or corrosion.</li> </ul>
251	1	Power Supply	Voltage too low.	An under-voltage has occurred.	<ul style="list-style-type: none"> <li>Verify correct installation.</li> <li>Verify the RSS ECU power connector is seated correctly and has no signs of moisture or corrosion.</li> <li>Verify correct power, ground at the main RSS ECU power connector and load test the power and ground circuit.</li> <li>Verify cable integrity and assure it is seated correctly and has no signs of moisture or corrosion.</li> </ul>

4012967a

# Diagnostics

SID	FMI	Suspect Component and Location	Fault Description (FMI)	Cause	Repair Information
251	2	Power Supply	Data is irregular or incorrect.	Vehicle was operated via stop light power.	<ul style="list-style-type: none"> <li>• Verify correct installation.</li> <li>• Verify the RSS ECU power connector is seated correctly and has no signs of moisture or corrosion.</li> <li>• Verify correct power, ground at the main RSS ECU power connector and load test the power and ground circuit.</li> <li>• Verify cable integrity and assure it is seated correctly and has no signs of moisture or corrosion.</li> </ul>
251	3	Power Supply	Voltage too high.	Voltage from towing vehicle too high.	<ul style="list-style-type: none"> <li>• Verify correct installation.</li> <li>• Verify the RSS ECU power connector is seated correctly and has no signs of moisture or corrosion.</li> <li>• Verify correct power, ground at the main RSS ECU power connector and load test the power and ground circuit.</li> <li>• Verify cable integrity and assure it is seated correctly and has no signs of moisture or corrosion.</li> </ul>
251	4	Power Supply	Under-voltage or short to ground.	Voltage from towing vehicle is below 16 volts.	<ul style="list-style-type: none"> <li>• Verify correct installation.</li> <li>• Verify the RSS ECU power connector is seated correctly and has no signs of moisture or corrosion.</li> <li>• Verify correct power, ground at the main RSS ECU power connector and load test the power and ground circuit.</li> <li>• Verify cable integrity and assure it is seated correctly and has no signs of moisture or corrosion.</li> </ul>
251	5	Power Supply	Supply cable interruption.	The ground circuit is intermittent or broken.	<ul style="list-style-type: none"> <li>• Verify correct installation.</li> <li>• Verify the RSS ECU power connector is seated correctly and has no signs of moisture or corrosion.</li> <li>• Verify correct power, ground at the main RSS ECU power connector and load test the power and ground circuit.</li> <li>• Verify cable integrity and assure it is seated correctly and has no signs of moisture or corrosion.</li> </ul>
251	12	Power Supply	Under-voltage or short to ground (driving).	Under-voltage occurred while driving.	<ul style="list-style-type: none"> <li>• Verify correct installation.</li> <li>• Verify the RSS ECU power connector is seated correctly and has no signs of moisture or corrosion.</li> <li>• Verify correct power, ground at the main RSS ECU power connector and load test the power and ground circuit.</li> <li>• Verify cable integrity and assure it is seated correctly and has no signs of moisture or corrosion.</li> </ul>
253	2	Parameter Setting	Internal checksum error.	ECU internal checksum error.	<ul style="list-style-type: none"> <li>• Verify correct installation and that the correct parameters are set for the application.</li> <li>• Verify the RSS ECU power connector is seated correctly and has no signs of moisture or corrosion.</li> <li>• Verify correct power, ground at the main RSS ECU power connector and load test the power and ground circuit.</li> <li>• Verify cable integrity and assure it is seated correctly and has no signs of moisture or corrosion.</li> </ul>

4012968a



SID	FMI	Suspect Component and Location	Fault Description (FMI)	Cause	Repair Information
253	12	Parameter Setting	Internal checksum error.	ECU detected checksum error.	<ul style="list-style-type: none"> <li>Verify correct installation and that the correct parameters are set for the application.</li> <li>Verify the RSS ECU power connector is seated correctly and has no signs of moisture or corrosion.</li> <li>Verify correct power, ground at the main RSS ECU power connector and load test the power and ground circuit.</li> <li>Verify cable integrity and assure it is seated correctly and has no signs of moisture or corrosion.</li> </ul>
253	14	Special Fault	Initialization start up error.	Vehicle has not been put into operation.	<ul style="list-style-type: none"> <li>Verify correct installation and run initial start routine.</li> <li>Verify the RSS ECU power connector is seated correctly and has no signs of moisture or corrosion.</li> <li>Verify correct power, ground at the main RSS ECU power connector and load test the power and ground circuit.</li> </ul>
254	3	Internal Error	Over-voltage or short to supply.	ECU has detected an over-voltage condition.	<ul style="list-style-type: none"> <li>Verify the RSS ECU power connector is seated correctly and has no signs of moisture or corrosion.</li> <li>Verify correct power, ground at the main RSS ECU power connector and load test the power and ground circuit.</li> </ul>
254	4	Internal Error	Under-voltage or short to ground.	ECU has detected an under-voltage condition.	<ul style="list-style-type: none"> <li>Verify the RSS ECU power connector is seated correctly and has no signs of moisture or corrosion.</li> <li>Verify correct power, ground at the main RSS ECU power connector and load test the power and ground circuit.</li> </ul>
254	11	Internal Error	Internal memory bit error.	ECU has detected an internal error on self check.	<ul style="list-style-type: none"> <li>Verify the RSS ECU power connector is seated correctly and has no signs of moisture or corrosion.</li> <li>Verify correct power, ground at the main RSS ECU power connector and load test the power and ground circuit.</li> </ul>
254	12	Internal Error	Internal error.	ECU has detected an internal error on self check.	<ul style="list-style-type: none"> <li>Verify the RSS ECU power connector is seated correctly and has no signs of moisture or corrosion.</li> <li>Verify correct power, ground at the main RSS ECU power connector and load test the power and ground circuit.</li> </ul>

4012969a

## 7.5.4 TailGUARD Diagnostic Codes

For more information related to the TailGUARD system, refer to TP19007.

# Diagnostics

Fault Code	Suspect Component and Location	Description	Cause	Repair Information
47113.09	CAN data connection to the RSSplus modulator	Signal failure	No CAN connection to the RSSplus	<ul style="list-style-type: none"> <li>• Check the cable between the Electronic Extension Module's power connector and the TEBS subsystem connector. With Truck and Bus Application (without TEBS-E) this fault should be ignored.</li> </ul>
64782.14	EOL test TailGUARD	Value too high	The TailGUARD system was not learned or tested yet	<ul style="list-style-type: none"> <li>• Please run initial start-up routine.yyyy</li> </ul>
65036.12	ECU	Value too high	The port expansion was deactivated	<ul style="list-style-type: none"> <li>• Too many 12V components were defined on the Electronic Extension Module in multivoltage operation. Reduce the number to max. 3 components.</li> </ul>
65052.12	ECU	Value too high	Switch ignition off for at least 5s	<ul style="list-style-type: none"> <li>• If the fault is still current after the ignition reset, contact the WABCO Customer Care Center at 855 228-3203.</li> </ul>
65068.12	ECU	Value too high	Switch ignition off for at least 5s	<ul style="list-style-type: none"> <li>• If the fault is still current after the ignition reset, contact the WABCO Customer Care Center at 855 228-3203.</li> </ul>
65084.12	ECU	Value too high	Switch ignition off for at least 5s	<ul style="list-style-type: none"> <li>• If the fault is still current after the ignition reset, contact the WABCO Customer Care Center at 855 228-3203.</li> </ul>
65100.12	ECU	Value too high	Switch ignition off for at least 5s	<ul style="list-style-type: none"> <li>• If the fault is still current after the ignition reset, contact the WABCO Customer Care Center at 855 228-3203.</li> </ul>
65116.12	ECU	Value too high	Switch ignition off for at least 5s	<ul style="list-style-type: none"> <li>• If the fault is still current after the ignition reset, contact the WABCO Customer Care Center at 855 228-3203.</li> </ul>
65420.12	ECU	Value too high	Switch ignition off for at least 5s	<ul style="list-style-type: none"> <li>• If the fault is still current after the ignition reset, contact the WABCO Customer Care Center at 855 228-3203.</li> </ul>

# Diagnostics

Fault Code	Suspect Component and Location	Description	Cause	Repair Information
26123.11	GIO14	Power stage GIO14 pin1 - A component that was not parameterised was detected on slot GIO14 pin1	A component that was not parameterised was detected on slot GIO14 pin1	<ul style="list-style-type: none"> <li>Run the TailGUARD EOL procedure again.</li> </ul>
26117.05	GIO14	Break in supply cable	The component or the cable on the connector GIO14 pin1 is not connected	<ul style="list-style-type: none"> <li>Check the cable between the control unit and the connected component. Check for tight seat of the connectors. Check whether the cable is frayed. If no fault can be identified, replace the connected component.</li> </ul>
26116.04	GIO14	Undervoltage/ Short circuit to ground	The component or the cable on connector GIO14 pin 1 has a short circuit to ground	<ul style="list-style-type: none"> <li>Disconnect the connector from the affected GIO port on the Electronic Extension Module.</li> <li>Open the fault memory and click on "Refresh".</li> <li>Case 1: Generally the fault should now no longer be signalled as active (attention: Note the exact fault code!! Since the connector has been disconnected from the control unit, a different fault may now be indicated as active!!). To check whether the component connected to the control unit with the cable is defective or the cable itself, disconnect the plug connection from the connected component(s); in the next step, reconnect the connector that was disconnected during the first step to the control unit so that the cable, but not the component connected to the control unit, is connected.</li> <li>Update the fault memory again.</li> <li>Case 1.1: Now the fault is indicated as active again (attention: Note the exact fault code!! Since the connector has been disconnected from the control unit, a different fault may now be indicated as active!!). In this case the cable is defective. Check the cable between the control unit and the connected component. Use a multimeter (throughput measurement) to check if there is a short circuit from one plug pin to another pin on the cable connector. Check whether the cable is frayed. If this is the case, replace the cable.</li> <li>Case 1.2: If the fault is not indicated as active again, it is presumably the component connected to the cable that is defective. Check the connector on the connected component. Check if the component has a short circuit. Check whether water or moisture has entered into one of the connectors and check the seals for proper fit.</li> <li>Case 2: If the same fault is now still signalled as active, the Electronic Extension Module is defective (attention: Note the exact fault code!! Since the connector has been disconnected from the control unit, a different fault may now be indicated as active!!).</li> </ul>

Fault Code	Suspect Component and Location	Description	Cause	Repair Information
26115.03	GIO14	Overvoltage/ Short circuit to 24 V	The component or the cable on connector GIO14 pin 1 has a short circuit to 24V	<ul style="list-style-type: none"> <li>• Disconnect the connector from the affected GIO port on the Electronic Extension Module.</li> <li>• Open the fault memory and click on "Refresh".</li> <li>• Case 1: Generally the fault should now no longer be signalled as active (attention: Note the exact fault code!! Since the connector has been disconnected from the control unit, a different fault may now be indicated as active!!). To check whether the component connected to the control unit with the cable is defective or the cable itself, disconnect the plug connection from the connected component(s); in the next step, reconnect the connector that was disconnected during the first step to the control unit so that the cable, but not the component connected to the control unit, is connected.</li> <li>• Update the fault memory again.</li> <li>• Case 1.1: Now the fault is indicated as active again (attention: Note the exact fault code!! Since the connector has been disconnected from the control unit, a different fault may now be indicated as active!!). In this case the cable is defective. Check the cable between the control unit and the connected component. Use a multimeter (throughput measurement) to check if there is a short circuit from one plug pin to another pin on the cable connector. Check whether the cable is frayed. If this is the case, replace the cable.</li> <li>• Case 1.2: If the fault is not indicated as active again, it is presumably the component connected to the cable that is defective. Check the connector on the connected component. Check if the component has a short circuit. Check whether water or moisture has entered into one of the connectors and check the seals for proper fit.</li> <li>• Case 2: If the same fault is now still signalled as active, the Electronic Extension Module is defective (attention: Note the exact fault code!! Since the connector has been disconnected from the control unit, a different fault may now be indicated as active!!).</li> </ul>
24836.04	GIO14	Undervoltage/ Short circuit to ground	The component or the cable on analogue input 1 (GIO14) has a short circuit to ground	<ul style="list-style-type: none"> <li>• Disconnect the connector from the affected GIO port on the Electronic Extension Module.</li> <li>• Open the fault memory and click on "Refresh".</li> <li>• Case 1: Generally the fault should now no longer be signalled as active (attention: Note the exact fault code!! Since the connector has been disconnected from the control unit, a different fault may now be indicated as active!!). To check whether the component connected to the control unit with the cable is defective or the cable itself, disconnect the plug connection from the connected component(s); in the next step, reconnect the connector that was disconnected during the first step to the control unit so that the cable, but not the component connected to the control unit, is connected.</li> <li>• Update the fault memory again.</li> <li>• Case 1.1: Now the fault is indicated as active again (attention: Note the exact fault code!! Since the connector has been disconnected from the control unit, a different fault may now be indicated as active!!). In this case the cable is defective. Check the cable between the control unit and the connected component. Use a multimeter (throughput measurement) to check if there is a short circuit from one plug pin to another pin on the cable connector. Check whether the cable is frayed. If this is the case, replace the cable.</li> <li>• Case 1.2: If the fault is not indicated as active again, it is presumably the component connected to the cable that is defective. Check the connector on the connected component. Check if the component has a short circuit. Check whether water or moisture has entered into one of the connectors and check the seals for proper fit.</li> <li>• Case 2: If the same fault is now still signalled as active, the Electronic Extension Module is defective (attention: Note the exact fault code!! Since the connector has been disconnected from the control unit, a different fault may now be indicated as active!!).</li> </ul>

Fault Code	Suspect Component and Location	Description	Cause	Repair Information
24835.03	GIO14	Overvoltage/ Short circuit to 24 V	The component or the cable on analogue input 1 (GIO14) has a short circuit to 24V	<ul style="list-style-type: none"> <li>• Disconnect the connector from the affected GIO port on the Electronic Extension Module.</li> <li>• Open the fault memory and click on "Refresh";</li> <li>• Case 1: Generally the fault should now no longer be signalled as active (attention: Note the exact fault code!! Since the connector has been disconnected from the control unit, a different fault may now be indicated as active!!!). To check whether the component connected to the control unit with the cable is defective or the cable itself, disconnect the plug connection from the connected component(s); in the next step, reconnect the connector that was disconnected during the first step to the control unit so that the cable, but not the component connected to the control unit, is connected.</li> <li>• Update the fault memory again.</li> <li>• Case 1.1: Now the fault is indicated as active again (attention: Note the exact fault code!!! Since the connector has been disconnected from the control unit, a different fault may now be indicated as active!!!). In this case the cable is defective. Check the cable between the control unit and the connected component. Use a multimeter (throughput measurement) to check if there is a short circuit from one plug pin to another pin on the cable connector. Check whether the cable is frayed. If this is the case, replace the cable.</li> <li>• Case 1.2: If the fault is not indicated as active again, it is presumably the component connected to the cable that is defective. Check the connector on the connected component. Check if the component has a short circuit. Check whether water or moisture has entered into one of the connectors and check the seals for proper fit.</li> <li>• Case 2: If the same fault is now still signalled as active, the Electronic Extension Module is defective (attention: Note the exact fault code!!! Since the connector has been disconnected from the control unit, a different fault may now be indicated as active!!!).</li> </ul>

Fault Code	Suspect Component and Location	Description	Cause	Repair Information
30995.03	GIO18	Overvoltage/ Short circuit to 24 V	The cable for the power supply for the ultrasonic sensor(s) on GIO 18 cable has a short-circuit to 24V	<ul style="list-style-type: none"> <li>• Disconnect the connector from the affected GIO port on the Electronic Extension Module.</li> <li>• Open the fault memory and click on "Refresh";</li> <li>• Case 1: Generally the fault should now no longer be signalled as active (attention: Note the exact fault code!!! Since the connector has been disconnected from the control unit, a different fault may now be indicated as active!!!). To check whether the component connected to the control unit with the cable is defective or the cable itself, disconnect the plug connection from the connected component(s); in the next step, reconnect the connector that was disconnected during the first step to the control unit so that the cable, but not the component connected to the control unit, is connected.</li> <li>• Update the fault memory again.</li> <li>• Case 1.1: Now the fault is indicated as active again (attention: Note the exact fault code!!! Since the connector has been disconnected from the control unit, a different fault may now be indicated as active!!!). In this case the cable is defective. Check the cable between the control unit and the connected component. Use a multimeter (throughput measurement) to check if there is a short circuit from one plug pin to another pin on the cable connector. Check whether the cable is frayed. If this is the case, replace the cable.</li> <li>• Case 1.2: If the fault is not indicated as active again, it is presumably the component connected to the cable that is defective. Check the connector on the connected component. Check if the component has a short circuit. Check whether water or moisture has entered into one of the connectors and check the seals for proper fit.</li> <li>• Case 2: If the same fault is now still signalled as active, the Electronic Extension Module is defective (attention: Note the exact fault code!!! Since the connector has been disconnected from the control unit, a different fault may now be indicated as active!!!).</li> </ul>
30996.04	GIO17/18	Undervoltage/ Short circuit to ground	The cable for the power supply for the ultrasonic sensor(s) on GIO 17 or GIO18 has a short-circuit to ground	<ul style="list-style-type: none"> <li>• Disconnect the connector from the affected GIO port on the Electronic Extension Module.</li> <li>• Open the fault memory and click on "Refresh";</li> <li>• Case 1: Generally the fault should now no longer be signalled as active (attention: Note the exact fault code!!! Since the connector has been disconnected from the control unit, a different fault may now be indicated as active!!!). To check whether the component connected to the control unit with the cable is defective or the cable itself, disconnect the plug connection from the connected component(s); in the next step, reconnect the connector that was disconnected during the first step to the control unit so that the cable, but not the component connected to the control unit, is connected.</li> <li>• Update the fault memory again.</li> <li>• Case 1.1: Now the fault is indicated as active again (attention: Note the exact fault code!!! Since the connector has been disconnected from the control unit, a different fault may now be indicated as active!!!). In this case the cable is defective. Check the cable between the control unit and the connected component. Use a multimeter (throughput measurement) to check if there is a short circuit from one plug pin to another pin on the cable connector. Check whether the cable is frayed. If this is the case, replace the cable.</li> <li>• Case 1.2: If the fault is not indicated as active again, it is presumably the component connected to the cable that is defective. Check the connector on the connected component. Check if the component has a short circuit. Check whether water or moisture has entered into one of the connectors and check the seals for proper fit.</li> <li>• Case 2: If the same fault is now still signalled as active, the Electronic Extension Module is defective (attention: Note the exact fault code!!! Since the connector has been disconnected from the control unit, a different fault may now be indicated as active!!!).</li> </ul>

Fault Code	Suspect Component and Location	Description	Cause	Repair Information
33283.03	GIO17/18	Overvoltage/ short circuit to 24 V	The LIN bus to the ultrasonic sensors (GIO17 or GIO18) is impaired due to excessive voltage. Check the sensor cable.	<ul style="list-style-type: none"> <li>• Disconnect the connector from the affected GIO port on the Electronic Extension Module.</li> <li>• Open the fault memory and click on "Refresh";</li> <li>• Case 1: Generally the fault should now no longer be signalled as active (attention: Note the exact fault code!! Since the connector has been disconnected from the control unit, a different fault may now be indicated as active!!). To check whether the component connected to the control unit with the cable is defective or the cable itself, disconnect the plug connection from the connected component(s); in the next step, reconnect the connector that was disconnected during the first step to the control unit so that the cable, but not the component connected to the control unit, is connected.</li> <li>• Update the fault memory again.</li> <li>• Case 1.1: Now the fault is indicated as active again (attention: Note the exact fault code!! Since the connector has been disconnected from the control unit, a different fault may now be indicated as active!!). In this case the cable is defective. Check the cable between the control unit and the connected component. Use a multimeter (throughput measurement) to check if there is a short circuit from one plug pin to another pin on the cable connector. Check whether the cable is frayed. If this is the case, replace the cable.</li> <li>• Case 1.2: If the fault is not indicated as active again, it is presumably the component connected to the cable that is defective. Check the connector on the connected component. Check if the component has a short circuit. Check whether water or moisture has entered into one of the connectors and check the seals for proper fit.</li> <li>• Case 2: If the same fault is now still signalled as active, the Electronic Extension Module is defective (attention: Note the exact fault code!! Since the connector has been disconnected from the control unit, a different fault may now be indicated as active!!).</li> </ul>
33285.05	GIO17/18	Break in supply cable	No sensor is connected to the LIN bus cable to the ultrasonic sensors (GIO 17 or GIO 18)	<ul style="list-style-type: none"> <li>• Check the cable between the control unit and the connected component.</li> <li>• Check for tight seat of the connectors. Check whether the cable is frayed.</li> <li>• If no fault can be identified, replace the connected component.</li> </ul>
33289.09	GIO17/18	Signal failure	The LIN bus to the ultrasonic sensors has communication problems	<ul style="list-style-type: none"> <li>• Switch the ignition off and on again. Check the cable of the ultrasonic sensors (cable to ELEX GIO 17 / GIO 18; 449 806 0)</li> </ul>



Fault Code	Suspect Component and Location	Description	Cause	Repair Information
33299.03	GIO17/18	Overvoltage/ short circuit to 24 V	The LIN bus to the ultrasonic sensors (GIO17 or GIO18) is impaired due to excessive voltage	<ul style="list-style-type: none"> <li>• Disconnect the connector from the affected GIO port on the Electronic Extension Module.</li> <li>• Open the fault memory and click on "Refresh";</li> <li>• Case 1: Generally the fault should now no longer be signalled as active (attention: Note the exact fault code!!! Since the connector has been disconnected from the control unit, a different fault may now be indicated as active!!!). To check whether the component connected to the control unit with the cable is defective or the cable itself, disconnect the plug connection from the connected component(s); in the next step, reconnect the connector that was disconnected during the first step to the control unit so that the cable, but not the component connected to the control unit, is connected.</li> <li>• Update the fault memory again.</li> <li>• Case 1.1: Now the fault is indicated as active again (attention: Note the exact fault code!!! Since the connector has been disconnected from the control unit, a different fault may now be indicated as active!!!). In this case the cable is defective. Check the cable between the control unit and the connected component. Use a multimeter (throughput measurement) to check if there is a short circuit from one plug pin to another pin on the cable connector. Check whether the cable is frayed. If this is the case, replace the cable.</li> <li>• Case 1.2: If the fault is not indicated as active again, it is presumably the component connected to the cable that is defective. Check the connector on the connected component. Check if the component has a short circuit. Check whether water or moisture has entered into one of the connectors and check the seals for proper fit.</li> <li>• Case 2: If the same fault is now still signalled as active, the Electronic Extension Module is defective (attention: Note the exact fault code!!! Since the connector has been disconnected from the control unit, a different fault may now be indicated as active!!!).</li> </ul>
33300.04	GIO17/18	Undervoltage/ Short circuit to ground	The LIN bus to the ultrasonic sensors (GIO17 or GIO18) has a short circuit to ground	<ul style="list-style-type: none"> <li>• Disconnect the connector from the affected GIO port on the Electronic Extension Module.</li> <li>• Open the fault memory and click on "Refresh";</li> <li>• Case 1: Generally the fault should now no longer be signalled as active (attention: Note the exact fault code!!! Since the connector has been disconnected from the control unit, a different fault may now be indicated as active!!!). To check whether the component connected to the control unit with the cable is defective or the cable itself, disconnect the plug connection from the connected component(s); in the next step, reconnect the connector that was disconnected during the first step to the control unit so that the cable, but not the component connected to the control unit, is connected.</li> <li>• Update the fault memory again.</li> <li>• Case 1.1: Now the fault is indicated as active again (attention: Note the exact fault code!!! Since the connector has been disconnected from the control unit, a different fault may now be indicated as active!!!). In this case the cable is defective. Check the cable between the control unit and the connected component. Use a multimeter (throughput measurement) to check if there is a short circuit from one plug pin to another pin on the cable connector. Check whether the cable is frayed. If this is the case, replace the cable.</li> <li>• Case 1.2: If the fault is not indicated as active again, it is presumably the component connected to the cable that is defective. Check the connector on the connected component. Check if the component has a short circuit. Check whether water or moisture has entered into one of the connectors and check the seals for proper fit.</li> <li>• Case 2: If the same fault is now still signalled as active, the Electronic Extension Module is defective (attention: Note the exact fault code!!! Since the connector has been disconnected from the control unit, a different fault may now be indicated as active!!!).</li> </ul>



Fault Code	Suspect Component and Location	Description	Cause	Repair Information
33309.13	GIO17/18	System Failure	The ultrasonic sensors are not configured	<ul style="list-style-type: none"> <li>Run the TailGUARD EOL procedure again.</li> </ul>
64003.03	GIO17/18	Overvoltage/ Short circuit to 24 V	The supply voltage to the ultrasonic sensors is too high.	
64004.04	GIO17/18	Undervoltage/ Short circuit to ground	The supply voltage to the ultrasonic sensors is too low.	<ul style="list-style-type: none"> <li>This fault can also occur in combination with the fault "power supply too low", then ignore.</li> </ul>
30740.04	Power supply for ultrasonic sensor GIO 17/18	Undervoltage/ Short circuit to ground	The cable for the power supply for the ultrasonic sensor(s) on GIO 17 or GIO18 has a short-circuit to ground	<ul style="list-style-type: none"> <li>Disconnect the connector from the affected GIO port on the Electronic Extension Module.</li> <li>Open the fault memory and click on "Refresh";</li> <li>Case 1: Generally the fault should now no longer be signalled as active (attention: Note the exact fault code!!! Since the connector has been disconnected from the control unit, a different fault may now be indicated as active!!!). To check whether the component connected to the control unit with the cable is defective or the cable itself, disconnect the plug connection from the connected component(s); in the next step, reconnect the connector that was disconnected during the first step to the control unit so that the cable, but not the component connected to the control unit, is connected.</li> <li>Update the fault memory again.</li> <li>Case 1.1: Now the fault is indicated as active again (attention: Note the exact fault code!!! Since the connector has been disconnected from the control unit, a different fault may now be indicated as active!!!). In this case the cable is defective. Check the cable between the control unit and the connected component. Use a multimeter (throughput measurement) to check if there is a short circuit from one plug pin to another pin on the cable connector. Check whether the cable is frayed. If this is the case, replace the cable.</li> <li>Case 1.2: If the fault is not indicated as active again, it is presumably the component connected to the cable that is defective. Check the connector on the connected component. Check if the component has a short circuit. Check whether water or moisture has entered into one of the connectors and check the seals for proper fit.</li> <li>Case 2: If the same fault is now still signalled as active, the Electronic Extension Module is defective (attention: Note the exact fault code!!! Since the connector has been disconnected from the control unit, a different fault may now be indicated as active!!!).</li> </ul>

Fault Code	Suspect Component and Location	Description	Cause	Repair Information
30739.03	Power supply for ultrasonic sensor GIO 17	Overvoltage/ Short circuit to 24 V	The cable for the power supply for the ultrasonic sensor(s) on GIO 17 cable has a short-circuit to 24V	<ul style="list-style-type: none"> <li>• Disconnect the connector from the affected GIO port on the Electronic Extension Module.</li> <li>• Open the fault memory and click on "Refresh";</li> <li>• Case 1: Generally the fault should now no longer be signalled as active (attention: Note the exact fault code!!! Since the connector has been disconnected from the control unit, a different fault may now be indicated as active!!!). To check whether the component connected to the control unit with the cable is defective or the cable itself, disconnect the plug connection from the connected component(s); in the next step, reconnect the connector that was disconnected during the first step to the control unit so that the cable, but not the component connected to the control unit, is connected.</li> <li>• Update the fault memory again.</li> <li>• Case 1.1: Now the fault is indicated as active again (attention: Note the exact fault code!!! Since the connector has been disconnected from the control unit, a different fault may now be indicated as active!!!). In this case the cable is defective. Check the cable between the control unit and the connected component. Use a multimeter (throughput measurement) to check if there is a short circuit from one plug pin to another pin on the cable connector. Check whether the cable is frayed. If this is the case, replace the cable.</li> <li>• Case 1.2: If the fault is not indicated as active again, it is presumably the component connected to the cable that is defective. Check the connector on the connected component. Check if the component has a short circuit. Check whether water or moisture has entered into one of the connectors and check the seals for proper fit.</li> <li>• Case 2: If the same fault is now still signalled as active, the Electronic Extension Module is defective (attention: Note the exact fault code!!! Since the connector has been disconnected from the control unit, a different fault may now be indicated as active!!!).</li> </ul>
64786.02	Parameter setting	Value too high	The parameter settings are incorrect	<ul style="list-style-type: none"> <li>• For more information: Read out the parameter set and write it back to the ECU.</li> </ul>
642590.03	Power supply	Value too high	The supply voltage to Electronic Extension Module is above 30 V	<ul style="list-style-type: none"> <li>• Check supply voltage.</li> </ul>
64260.04	Power supply	Value too low	The supply voltage to Electronic Extension Module is below 9 V	<ul style="list-style-type: none"> <li>• Check supply voltage.</li> </ul>

Fault Code	Suspect Component and Location	Description	Cause	Repair Information
64275. 03	Power supply	Value too high	The supply voltage to the Electronic Extension Module is too high. The reverse monitoring system was switched off.	<ul style="list-style-type: none"> <li>• Check supply voltage</li> </ul>
35899.11	Rear outline marker lamp	Lamp Failure	Internal fault, the relay for the position lights has a fault	<ul style="list-style-type: none"> <li>• The system has detected a malfunction on one of the relays responsible for controlling the rear outline marker lamps. This may have the following causes:</li> <li>• Very low temperatures in combination with low supply voltage: In very low temperatures the relay may not switch correctly from time to time, causing a fault to be detected. Check the function of the rear outline marker lamps: Select the "Electronic Extension Module signal outputs" menu item from the "Measured values" menu and there activate the rear outline marker lamps. Check if the rear outline marker lamps can be switched on and off via diagnosis. If the fault no longer occurs, ignore the fault and delete the fault memory.</li> <li>• Only following installation or repair of the TailGUARD system: Check the cabling of the rear outline marker lamps: The connections to rear outline marker lamps must be connected to GIO 12, pin 6 (yellow-black core, rear outline marker lamp left) and pin 7 (yellow-brown core, position light right); pin 1 (pink, power supply) and pin 4 (white, ground)</li> <li>• The relays of the electronic extension module are defective. Either replace the electronic extension module or use one of the following (more economical) alternatives:             <ul style="list-style-type: none"> <li>• To deactivate the rear outline marker lamps, proceed as follows:</li> <li>• Open the parameter setting dialogue in the diagnosis, under "Options" in tab "(10) Electronic Extension Module" deactivate the "Marker lights control" checkbox.</li> <li>• Follow the cable from Electronic Extension Module GIO port 12 to the light distributor. In the light distributor, reconnect the rear outline marker lamp contacts directly to the associated light cable contacts, i.e.: The contacts connected to the yellow-black core of the GIO12 cable must now be connected directly to one another. The black and yellow-black cores of the GIO12 cable are no longer connected. The contacts connected to the brown and the yellow-brown core of the GIO12 cable must also be connected directly to one another. The brown and yellow-brown cores of the GIO12 cable are no longer connected.</li> </ul> </li> </ul>

# Diagnostics

Fault Code	Suspect Component and Location	Description	Cause	Repair Information
38405.05	Stop light	Break in supply cable	The supply cable for the stop light (GIO 12 - pin 1) is not connected. The stop light cannot be actuated.	<ul style="list-style-type: none"> <li>• Check the cabling.</li> </ul>
31502.14	TailGUARD	System Failure	TailGUARD was deactivated during reverse driving	
31500.12	TailGUARD light	System Failure	TailGUARD function cancelled due to a sensor error. This error can also occur with heavy parasitic noises	<ul style="list-style-type: none"> <li>• This fault occurs when the ultrasonic sensors do not supply correct data, e.g. because they exposed to intense background noise or the sensor membrane was contaminated or covered. Generally the fault is therefore not stored as active in the fault memory as it occurs only temporarily during operation with intense background noise and the system functions again correctly in a different/quieter environment or the system is ready for operation again after the sensors are cleaned (snow melts / rain washes dirt away / the vehicle is cleaned).</li> <li>• Proceed as follows to check the system:               <ul style="list-style-type: none"> <li>• Switch the ignition off and on again or carry out an ECU reset via the PC diagnosis.</li> <li>• Then reverse the vehicle to check if the system functions (distance indication and brake intervention in front of an object).</li> <li>• If the fault does not reoccur and there are no other faults in the fault memory, ignore the fault and delete it.</li> </ul> </li> </ul>
31516.12	TailGUARD light	System Failure	TailGUARD function cancelled due to a sensor error in the extended level. This error can also occur with heavy parasitic noises	<ul style="list-style-type: none"> <li>• This fault occurs when the ultrasonic sensors do not supply correct data, e.g. because they exposed to intense background noise or the sensor membrane was contaminated or covered. Generally the fault is therefore not stored as active in the fault memory as it occurs only temporarily during operation with intense background noise and the system functions again correctly in a different/quieter environment or the system is ready for operation again after the sensors are cleaned (snow melts / rain washes dirt away / the vehicle is cleaned).</li> <li>• Proceed as follows to check the system:               <ul style="list-style-type: none"> <li>• Switch the ignition off and on again or carry out an ECU reset via the PC diagnosis.</li> <li>• Then reverse the vehicle to check if the system functions (distance indication and brake intervention in front of an object).</li> <li>• If the fault does not reoccur and there are no other faults in the fault memory, ignore the fault and delete it.</li> </ul> </li> </ul>

Fault Code	Suspect Component and Location	Description	Cause	Repair Information
30724.04	Ultrasonic sensor 1 (Left)	Undervoltage/ Short circuit to ground	The cable to ultrasonic sensor 1 (Left) has a short circuit to ground	<ul style="list-style-type: none"> <li>• Disconnect the connector from the affected GIO port on the Electronic Extension Module.</li> <li>• Open the fault memory and click on "Refresh";</li> <li>• Case 1: Generally the fault should now no longer be signalled as active (attention: Note the exact fault code!! Since the connector has been disconnected from the control unit, a different fault may now be indicated as active!!!). To check whether the component connected to the control unit with the cable is defective or the cable itself, disconnect the plug connection from the connected component(s); in the next step, reconnect the connector that was disconnected during the first step to the control unit so that the cable, but not the component connected to the control unit, is connected.</li> <li>• Update the fault memory again.</li> <li>• Case 1.1: Now the fault is indicated as active again (attention: Note the exact fault code!!! Since the connector has been disconnected from the control unit, a different fault may now be indicated as active!!!). In this case the cable is defective. Check the cable between the control unit and the connected component. Use a multimeter (throughput measurement) to check if there is a short circuit from one plug pin to another pin on the cable connector. Check whether the cable is frayed. If this is the case, replace the cable.</li> <li>• Case 1.2: If the fault is not indicated as active again, it is presumably the component connected to the cable that is defective. Check the connector on the connected component. Check if the component has a short circuit. Check whether water or moisture has entered into one of the connectors and check the seals for proper fit.</li> <li>• Case 2: If the same fault is now still signalled as active, the Electronic Extension Module is defective (attention: Note the exact fault code!!! Since the connector has been disconnected from the control unit, a different fault may now be indicated as active!!!).</li> </ul>

Fault Code	Suspect Component and Location	Description	Cause	Repair Information
30979.03	Ultrasonic sensor 2 (Right)	Overvoltage/ Short circuit to 12 V	The cable to ultrasonic sensor 2 (Right) has a short circuit to 24V	<ul style="list-style-type: none"> <li>• Disconnect the connector from the affected GIO port on the Electronic Extension Module.</li> <li>• Open the fault memory and click on "Refresh";</li> <li>• Case 1: Generally the fault should now no longer be signalled as active (attention: Note the exact fault code!! Since the connector has been disconnected from the control unit, a different fault may now be indicated as active!!!). To check whether the component connected to the control unit with the cable is defective or the cable itself, disconnect the plug connection from the connected component(s), in the next step, reconnect the connector that was disconnected during the first step to the control unit so that the cable, but not the component connected to the control unit, is connected.</li> <li>• Update the fault memory again.</li> <li>• Case 1.1: Now the fault is indicated as active again (attention: Note the exact fault code!!! Since the connector has been disconnected from the control unit, a different fault may now be indicated as active!!!). In this case the cable is defective. Check the cable between the control unit and the connected component. Use a multimeter (throughput measurement) to check if there is a short circuit from one plug pin to another pin on the cable connector. Check whether the cable is frayed. If this is the case, replace the cable.</li> <li>• Case 1.2: If the fault is not indicated as active again, it is presumably the component connected to the cable that is defective. Check the connector on the connected component. Check if the component has a short circuit. Check whether water or moisture has entered into one of the connectors and check the seals for proper fit.</li> <li>• Case 2: If the same fault is now still signalled as active, the Electronic Extension Module is defective (attention: Note the exact fault code!!! Since the connector has been disconnected from the control unit, a different fault may now be indicated as active!!!).</li> </ul>

Fault Code	Suspect Component and Location	Description	Cause	Repair Information
30980.04	Ultrasonic sensor 2 (Right)	Undervoltage/ Short circuit to ground	The cable to ultrasonic sensor 2 (Right) has a short circuit to ground	<ul style="list-style-type: none"> <li>• Disconnect the connector from the affected GIO port on the Electronic Extension Module.</li> <li>• Open the fault memory and click on "Refresh";</li> <li>• Case 1: Generally the fault should now no longer be signalled as active (attention: Note the exact fault code!!! Since the connector has been disconnected from the control unit, a different fault may now be indicated as active!!!). To check whether the component connected to the control unit with the cable is defective or the cable itself, disconnect the plug connection from the connected component(s); in the next step, reconnect the connector that was disconnected during the first step to the control unit so that the cable, but not the component connected to the control unit, is connected.</li> <li>• Update the fault memory again.</li> <li>• Case 1.1: Now the fault is indicated as active again (attention: Note the exact fault code!!! Since the connector has been disconnected from the control unit, a different fault may now be indicated as active!!!). In this case the cable is defective. Check the cable between the control unit and the connected component. Use a multimeter (throughput measurement) to check if there is a short circuit from one plug pin to another pin on the cable connector. Check whether the cable is frayed. If this is the case, replace the cable.</li> <li>• Case 1.2: If the fault is not indicated as active again, it is presumably the component connected to the cable that is defective. Check the connector on the connected component. Check if the component has a short circuit. Check whether water or moisture has entered into one of the connectors and check the seals for proper fit.</li> <li>• Case 2: If the same fault is now still signalled as active, the Electronic Extension Module is defective (attention: Note the exact fault code!!! Since the connector has been disconnected from the control unit, a different fault may now be indicated as active!!!).</li> </ul>
30978.02	Ultrasonic sensor 2 (Right)	Data is irregular or incorrect	No echo signal received from ultrasonic sensor 2 (Right). Sensor or sensor cable defective, or not plugged in.	<ul style="list-style-type: none"> <li>• Check if cable is connected to GIO port</li> </ul>

Fault Code	Suspect Component and Location	Description	Cause	Repair Information
33564.12	Ultrasonic sensor LIN 1 (main level Left)	Sensor Failure	The ultrasonic sensor 1 (main level Left) has an internal fault	<ul style="list-style-type: none"> <li>• The ultrasonic sensor 1 (main level Left) has an internal fault. If this fault occurs frequently, replace the sensor.</li> <li>• If the ultrasonic sensor needs to be replaced, proceed as follows:               <ul style="list-style-type: none"> <li>• Remove the sensor and disconnect the plug connection of the sensor cable.</li> <li>• Install the new sensor 446 122 450 0 and connect it.</li> </ul> </li> <li>• Start the TailGUARD Diagnostic Software via TOOLBOX. Note: A sensor may still be indicated as defective after it has been replaced; other sensors may now also be reported as defective in the fault memory. The reason for this is that the sensors need to be newly assigned after a sensor has been replaced. There is no new defect!</li> <li>• This step is optional, but may simplify the subsequent start-up procedure for the system: Select the "Settings" menu item from the "Options" menu and the "Test options" tab in the settings dialogue. In the "TailGUARD (RAS/RMS) test" group, deactivate the "Direct Echo Test (optional)" checkboxes as well as "Object test (optional)". This enables skipping the reflection test and the object detection test during start-up, thereby reducing the time required for the repair. Attention: This option should only be deactivated for the replacement of ultrasonic sensors in vehicles that have already been put into operation and should be reactivated after the repair. For the initial start-up after installation of a TailGUARD system, the option should be activated.</li> <li>• A new start-up procedure for the entire vehicle is not necessary. Only the TailGUARD function must be started up. Open the TailGUARD dialogue by selecting "TailGUARD" or TailGUARD light" from the "Measured values" menu.</li> <li>• In the TailGUARD dialogue, click the "Start initial start-up" button.</li> <li>• Follow the instructions on the screen.</li> <li>• WABCO part number for ultrasonic sensors: 446 122 450 0 LIN ultrasonic sensor, 1 0°, 3m cable length, not preconfigured - this sensor is used for TailGUARD light or for TailGUARD in all positions.</li> </ul>



Fault Code	Suspect Component and Location	Description	Cause	Repair Information
33580.12	Ultrasonic sensor LIN 1 (main level Left)	Sensor Failure	The ultrasonic sensor 1 (main level Left) is dirty or has a sensor membrane fault	<ul style="list-style-type: none"> <li>• Make sure that the sensor membrane is clean and the sensor has free view. If this fault occurs permanently, replace the sensor.</li> <li>• If the ultrasonic sensor needs to be replaced, proceed as follows:               <ul style="list-style-type: none"> <li>• Remove the sensor and disconnect the plug connection of the sensor cable.</li> <li>• Install the new sensor 446 122 450 0 and connect it.</li> <li>• Start the TailGUARD Diagnostic Software via TOOLBOX. Note: A sensor may still be indicated as defective after it has been replaced; other sensors may now also be reported as defective in the fault memory. The reason for this is that the sensors need to be newly assigned after a sensor has been replaced. There is no new defect!</li> <li>• This step is optional, but may simplify the subsequent start-up procedure for the system: Select the "Settings" menu item from the "Options" menu and the "Test options" tab in the settings dialogue. In the "TailGUARD (RAS/RMS) test" group, deactivate the "Direct Echo Test (optional)" checkboxes as well as "Object test (optional)". This enables skipping the reflection test and the object detection test during start-up, thereby reducing the time required for the repair. Attention: This option should only be deactivated for the replacement of ultrasonic sensors in vehicles that have already been put into operation and should be reactivated after the repair. For the initial start-up after installation of a TailGUARD system, the option should be activated.</li> <li>• A new start-up procedure for the entire vehicle is not necessary. Only the TailGUARD function must be started up. Open the TailGUARD dialogue by selecting "TailGUARD" or TailGUARD light" from the "Measured values" menu.</li> <li>• In the TailGUARD dialogue, click the "Start initial start-up" button.</li> <li>• Follow the instructions on the screen.</li> <li>• WABCO part number for ultrasonic sensors: 446 122 450 0 LIN ultrasonic sensor, 1 0°, 3m cable length, not preconfigured - this sensor is used for TailGUARD light or for TailGUARD in all positions.</li> </ul> </li> </ul>

Fault Code	Suspect Component and Location	Description	Cause	Repair Information
33584. 00	Ultrasonic sensor LIN 1 (main level Left)	Value too high	The ultrasonic sensor 1 (main level Left) has an internal fault	<ul style="list-style-type: none"> <li>• If this fault occurs frequently, replace the sensor.</li> <li>• If the ultrasonic sensor needs to be replaced, proceed as follows:               <ul style="list-style-type: none"> <li>• Remove the sensor and disconnect the plug connection of the sensor cable.</li> <li>• Install the new sensor 446 122 450 0 and connect it.</li> <li>• Start the TailGUARD Diagnostic Software via TOOLBOX. Note: A sensor may still be indicated as defective after it has been replaced; other sensors may now also be reported as defective in the fault memory. The reason for this is that the sensors need to be newly assigned after a sensor has been replaced. There is no new defect!</li> </ul> </li> <li>• This step is optional, but may simplify the subsequent start-up procedure for the system: Select the "Settings" menu item from the "Options" menu and the "Test options" tab in the settings dialogue. In the "TailGUARD (RAS/RMS) test" group, deactivate the "Direct Echo Test (optional)" checkboxes as well as "Object test (optional)". This enables skipping the reflection test and the object detection test during start-up, thereby reducing the time required for the repair. Attention: This option should only be deactivated for the replacement of ultrasonic sensors in vehicles that have already been put into operation and should be reactivated after the repair. For the initial start-up after installation of a TailGUARD system, the option should be activated.</li> <li>• A new start-up procedure for the entire vehicle is not necessary. Only the TailGUARD function must be started up. Open the TailGUARD dialogue by selecting "TailGUARD" or TailGUARD light" from the "Measured values" menu.</li> <li>• In the TailGUARD dialogue, click the "Start initial start-up" button.</li> <li>• Follow the instructions on the screen.</li> <li>• WABCO part number for ultrasonic sensors:446 122 450 0 LIN ultrasonic sensor,1 0°, 3m cable length, not preconfigured - this sensor is used for TailGUARD light or for TailGUARD in all positions.</li> </ul>

Fault Code	Suspect Component and Location	Description	Cause	Repair Information
33612.12	Ultrasonic sensor LIN 1 (main level Left)	Sensor Failure	The ultrasonic sensor 1 (main level Left) has an internal fault	<ul style="list-style-type: none"> <li>• If this fault occurs frequently, replace the sensor.</li> <li>• If the ultrasonic sensor needs to be replaced, proceed as follows:               <ul style="list-style-type: none"> <li>• Remove the sensor and disconnect the plug connection of the sensor cable.</li> <li>• Install the new sensor 446 122 450 0 and connect it.</li> </ul> </li> <li>• Start the TailGUARD Diagnostic Software via TOOLBOX. Note: A sensor may still be indicated as defective after it has been replaced; other sensors may now also be reported as defective in the fault memory. The reason for this is that the sensors need to be newly assigned after a sensor has been replaced. There is no new defect!</li> <li>• This step is optional, but may simplify the subsequent start-up procedure for the system: Select the "Settings" menu item from the "Options" menu and the "Test options" tab in the settings dialogue. In the "TailGUARD (RAS/RMS) test" group, deactivate the "Direct Echo Test (optional)" checkboxes as well as "Object test (optional)". This enables skipping the reflection test and the object detection test during start-up, thereby reducing the time required for the repair. Attention: This option should only be deactivated for the replacement of ultrasonic sensors in vehicles that have already been put into operation and should be reactivated after the repair. For the initial start-up after installation of a TailGUARD system, the option should be activated.</li> <li>• A new start-up procedure for the entire vehicle is not necessary. Only the TailGUARD function must be started up. Open the TailGUARD dialogue by selecting "TailGUARD" or TailGUARD light" from the "Measured values" menu.</li> <li>• In the TailGUARD dialogue, click the "Start initial start-up" button.</li> <li>• Follow the instructions on the screen.</li> <li>• WABCO part number for ultrasonic sensors:446 122 450 0 LIN ultrasonic sensor,1 0°, 3m cable length, not preconfigured - this sensor is used for TailGUARD light or for TailGUARD in all positions.</li> </ul>

Fault Code	Suspect Component and Location	Description	Cause	Repair Information
33628.12	Ultrasonic sensor LIN 1 (main level Left)	Sensor Failure	The ultrasonic sensor 1 (main level Left) has an internal fault	<ul style="list-style-type: none"> <li>• If this fault occurs frequently, replace the sensor.</li> <li>• If the ultrasonic sensor needs to be replaced, proceed as follows:               <ul style="list-style-type: none"> <li>• Remove the sensor and disconnect the plug connection of the sensor cable.</li> <li>• Install the new sensor 446 122 450 0 and connect it.</li> <li>• Start the TailGUARD Diagnostic Software via TOOLBOX. Note: A sensor may still be indicated as defective after it has been replaced; other sensors may now also be reported as defective in the fault memory. The reason for this is that the sensors need to be newly assigned after a sensor has been replaced. There is no new defect!</li> <li>• This step is optional, but may simplify the subsequent start-up procedure for the system: Select the "Settings" menu item from the "Options" menu and the "Test options" tab in the settings dialogue. In the "TailGUARD (RAS/RMS) test" group, deactivate the "Direct Echo Test (optional)" checkboxes as well as "Object test (optional)". This enables skipping the reflection test and the object detection test during start-up, thereby reducing the time required for the repair. Attention: This option should only be deactivated for the replacement of ultrasonic sensors in vehicles that have already been put into operation and should be reactivated after the repair. For the initial start-up after installation of a TailGUARD system, the option should be activated.</li> <li>• A new start-up procedure for the entire vehicle is not necessary. Only the TailGUARD function must be started up. Open the TailGUARD dialogue by selecting "TailGUARD" or TailGUARD light" from the "Measured values" menu.</li> <li>• In the TailGUARD dialogue, click the "Start initial start-up" button.</li> <li>• Follow the instructions on the screen.</li> <li>• WABCO part number for ultrasonic sensors:446 122 450 0 LIN ultrasonic sensor,1 0°, 3m cable length, not preconfigured - this sensor is used for TailGUARD light or for TailGUARD in all positions.</li> </ul> </li> </ul>

Fault Code	Suspect Component and Location	Description	Cause	Repair Information
33644.12	Ultrasonic sensor LIN 1 (main level Left)	Sensor Failure	The ultrasonic sensor 1 (main level Left) has a sensor membrane fault	<ul style="list-style-type: none"> <li>• Make sure that the sensor membrane is clean and the sensor has free view. If this fault occurs permanently, replace the sensor.</li> <li>• If the ultrasonic sensor needs to be replaced, proceed as follows:</li> <li>• Remove the sensor and disconnect the plug connection of the sensor cable.</li> <li>• Install the new sensor 446 122 450 0 and connect it.</li> <li>• Start the TailGUARD Diagnostic Software via TOOLBOX. Note: A sensor may still be indicated as defective after it has been replaced; other sensors may now also be reported as defective in the fault memory. The reason for this is that the sensors need to be newly assigned after a sensor has been replaced. There is no new defect!</li> <li>• This step is optional, but may simplify the subsequent start-up procedure for the system: Select the "Settings" menu item from the "Options" menu and the "Test options" tab in the settings dialogue. In the "TailGUARD (RAS/FMS) test" group, deactivate the "Direct Echo Test (optional)" checkboxes as well as "Object test (optional)". This enables skipping the reflection test and the object detection test during start-up, thereby reducing the time required for the repair. Attention: This option should only be deactivated for the replacement of ultrasonic sensors in vehicles that have already been put into operation and should be reactivated after the repair. For the initial start-up after installation of a TailGUARD system, the option should be activated.</li> <li>• A new start-up procedure for the entire vehicle is not necessary. Only the TailGUARD function must be started up. Open the TailGUARD dialogue by selecting "TailGUARD" or TailGUARD light" from the "Measured values" menu.</li> <li>• In the TailGUARD dialogue, click the "Start initial start-up" button.</li> <li>• Follow the instructions on the screen.</li> <li>• WABCO part number for ultrasonic sensors: 446 122 450 0 LIN ultrasonic sensor; 1 0°, 3m cable length, not preconfigured - this sensor is used for TailGUARD light or for TailGUARD in all positions.</li> </ul>

# Diagnostics

Fault Code	Suspect Component and Location	Description	Cause	Repair Information
33653.05	Ultrasonic sensor LIN 1 (main level Left)	Break in supply cable	The cable to the ultrasonic sensor 1 (main level Left) is interrupted or the new ultrasonic sensor has not yet been learned	<ul style="list-style-type: none"> <li>• If the fault occurs within the TailGUARD start-up procedure, ignore fault and repeat start-up procedure.</li> <li>• If the ultrasonic sensor needs to be replaced, proceed as follows:               <ul style="list-style-type: none"> <li>• Remove the sensor and disconnect the plug connection of the sensor cable.</li> <li>• Install the new sensor 446 122 450 0 and connect it.</li> <li>• Start the TailGUARD Diagnostic Software via TOOLBOX. Note: A sensor may still be indicated as defective after it has been replaced; other sensors may now also be reported as defective in the fault memory. The reason for this is that the sensors need to be newly assigned after a sensor has been replaced. There is no new defect!</li> <li>• This step is optional, but may simplify the subsequent start-up procedure for the system: Select the "Settings" menu item from the "Options" menu and the "Test options" tab in the settings dialogue. In the "TailGUARD (RAS/RMS) test" group, deactivate the "Direct Echo Test (optional)" checkboxes as well as "Object test (optional)". This enables skipping the reflection test and the object detection test during start-up, thereby reducing the time required for the repair. Attention: This option should only be deactivated for the replacement of ultrasonic sensors in vehicles that have already been put into operation and should be reactivated after the repair. For the initial start-up after installation of a TailGUARD system, the option should be activated.</li> <li>• A new start-up procedure for the entire vehicle is not necessary. Only the TailGUARD function must be started up. Open the TailGUARD dialogue by selecting "TailGUARD" or TailGUARD light" from the "Measured values" menu.</li> <li>• In the TailGUARD dialogue, click the "Start initial start-up" button.</li> <li>• Follow the instructions on the screen.</li> <li>• WABCO part number for ultrasonic sensors: 446 122 450 0 LIN ultrasonic sensor; 1 0°, 3m cable length, not preconfigured - this sensor is used for TailGUARD light or for TailGUARD in all positions.</li> </ul> </li> </ul>

Fault Code	Suspect Component and Location	Description	Cause	Repair Information
33820.12	Ultrasonic sensor LIN 2 (main level Right)	Sensor Failure	The ultrasonic sensor 2 (main level Right) has an internal fault	<ul style="list-style-type: none"> <li>• If this fault occurs frequently, replace the sensor.</li> <li>• If the ultrasonic sensor needs to be replaced, proceed as follows:               <ul style="list-style-type: none"> <li>• Remove the sensor and disconnect the plug connection of the sensor cable.</li> <li>• Install the new sensor 446 122 450 0 and connect it.</li> <li>• Start the TailGUARD Diagnostic Software via TOOLBOX. Note: A sensor may still be indicated as defective after it has been replaced; other sensors may now also be reported as defective in the fault memory. The reason for this is that the sensors need to be newly assigned after a sensor has been replaced. There is no new defect!</li> </ul> </li> <li>• This step is optional, but may simplify the subsequent start-up procedure for the system: Select the "Settings" menu item from the "Options" menu and the "Test options" tab in the settings dialogue. In the "TailGUARD (RAS/RMS) test" group, deactivate the "Direct Echo Test (optional)" checkboxes as well as "Object test (optional)". This enables skipping the reflection test and the object detection test during start-up, thereby reducing the time required for the repair. Attention: This option should only be deactivated for the replacement of ultrasonic sensors in vehicles that have already been put into operation and should be reactivated after the repair. For the initial start-up after installation of a TailGUARD system, the option should be activated.</li> <li>• A new start-up procedure for the entire vehicle is not necessary. Only the TailGUARD function must be started up. Open the TailGUARD dialogue by selecting "TailGUARD" or TailGUARD light" from the "Measured values" menu.</li> <li>• In the TailGUARD dialogue, click the "Start initial start-up" button.</li> <li>• Follow the instructions on the screen.</li> <li>• WABCO part number for ultrasonic sensors: 446 122 450 0 LIN ultrasonic sensor, 1 0°, 3m cable length, not preconfigured - this sensor is used for TailGUARD light or for TailGUARD in all positions.</li> </ul>



Fault Code	Suspect Component and Location	Description	Cause	Repair Information
33836.12	Ultrasonic sensor LIN 2 (main level Right)	Sensor Failure	The ultrasonic sensor 2 (main level Right) is dirty or has a sensor membrane fault	<ul style="list-style-type: none"> <li>• Make sure that the sensor membrane is clean and the sensor has free view. If this fault occurs permanently, replace the sensor.</li> <li>• If the ultrasonic sensor needs to be replaced, proceed as follows:               <ul style="list-style-type: none"> <li>• Remove the sensor and disconnect the plug connection of the sensor cable.</li> <li>• Install the new sensor 446 122 450 0 and connect it.</li> <li>• Start the TailGUARD Diagnostic Software via TOOLBOX. Note: A sensor may still be indicated as defective after it has been replaced; other sensors may now also be reported as defective in the fault memory. The reason for this is that the sensors need to be newly assigned after a sensor has been replaced. There is no new defect!</li> <li>• This step is optional, but may simplify the subsequent start-up procedure for the system: Select the "Settings" menu item from the "Options" menu and the "Test options" tab in the settings dialogue. In the "TailGUARD (RAS/RMS) test" group, deactivate the "Direct Echo Test (optional)" checkboxes as well as "Object test (optional)". This enables skipping the reflection test and the object detection test during start-up, thereby reducing the time required for the repair. Attention: This option should only be deactivated for the replacement of ultrasonic sensors in vehicles that have already been put into operation and should be reactivated after the repair. For the initial start-up after installation of a TailGUARD system, the option should be activated.</li> <li>• A new start-up procedure for the entire vehicle is not necessary. Only the TailGUARD function must be started up. Open the TailGUARD dialogue by selecting "TailGUARD" or TailGUARD light" from the "Measured values" menu.</li> <li>• In the TailGUARD dialogue, click the "Start initial start-up" button.</li> <li>• Follow the instructions on the screen.</li> <li>• WABCO part number for ultrasonic sensors: 446 122 450 0 LIN ultrasonic sensor; 1 0° , 3m cable length, not preconfigured - this sensor is used for TailGUARD light or for TailGUARD in all positions.</li> </ul> </li> </ul>



Fault Code	Suspect Component and Location	Description	Cause	Repair Information
33840. 00	Ultrasonic sensor LIN 2 (main level Right)	Value too high	The ultrasonic sensor 2 (main level Right) has an internal fault	<ul style="list-style-type: none"> <li>• If this fault occurs frequently, replace the sensor.</li> <li>• If the ultrasonic sensor needs to be replaced, proceed as follows:               <ul style="list-style-type: none"> <li>• Remove the sensor and disconnect the plug connection of the sensor cable.</li> <li>• Install the new sensor 446 122 450 0 and connect it.</li> <li>• Start the TailGUARD Diagnostic Software via TOOLBOX. Note: A sensor may still be indicated as defective after it has been replaced; other sensors may now also be reported as defective in the fault memory. The reason for this is that the sensors need to be newly assigned after a sensor has been replaced. There is no new defect!</li> </ul> </li> <li>• This step is optional, but may simplify the subsequent start-up procedure for the system: Select the "Settings" menu item from the "Options" menu and the "Test options" tab in the settings dialogue. In the "TailGUARD (RAS/RMS) test" group, deactivate the "Direct Echo Test (optional)" checkboxes as well as "Object test (optional)". This enables skipping the reflection test and the object detection test during start-up, thereby reducing the time required for the repair. Attention:               <ul style="list-style-type: none"> <li>• This option should only be deactivated for the replacement of ultrasonic sensors in vehicles that have already been put into operation and should be reactivated after the repair. For the initial start-up after installation of a TailGUARD system, the option should be activated.</li> <li>• A new start-up procedure for the entire vehicle is not necessary. Only the TailGUARD function must be started up. Open the TailGUARD dialogue by selecting "TailGUARD" or TailGUARD light" from the "Measured values" menu.</li> <li>• In the TailGUARD dialogue, click the "Start initial start-up" button.</li> <li>• Follow the instructions on the screen.</li> <li>• WABCO part number for ultrasonic sensors:446 122 450 0 LIN ultrasonic sensor, 1 0°, 3m cable length, not preconfigured - this sensor is used for TailGUARD light or for TailGUARD in all positions.</li> </ul> </li> </ul>

Fault Code	Suspect Component and Location	Description	Cause	Repair Information
33868.12	Ultrasonic sensor LIN 2 (main level Right)	Sensor Failure	The ultrasonic sensor 2 (main level Right) has an internal fault	<ul style="list-style-type: none"> <li>• If this fault occurs frequently, replace the sensor.</li> <li>• If the ultrasonic sensor needs to be replaced, proceed as follows:               <ul style="list-style-type: none"> <li>• Remove the sensor and disconnect the plug connection of the sensor cable.</li> <li>• Install the new sensor 446 122 450 0 and connect it.</li> </ul> </li> <li>• Start the TailGUARD Diagnostic Software via TOOLBOX. Note: A sensor may still be indicated as defective after it has been replaced; other sensors may now also be reported as defective in the fault memory. The reason for this is that the sensors need to be newly assigned after a sensor has been replaced. There is no new defect!</li> <li>• This step is optional, but may simplify the subsequent start-up procedure for the system: Select the "Settings" menu item from the "Options" menu and the "Test options" tab in the settings dialogue. In the "TailGUARD (RAS/RMS) test" group, deactivate the "Direct Echo Test (optional)" checkboxes as well as "Object test (optional)". This enables skipping the reflection test and the object detection test during start-up, thereby reducing the time required for the repair. Attention: This option should only be deactivated for the replacement of ultrasonic sensors in vehicles that have already been put into operation and should be reactivated after the repair. For the initial start-up after installation of a TailGUARD system, the option should be activated.</li> <li>• A new start-up procedure for the entire vehicle is not necessary. Only the TailGUARD function must be started up. Open the TailGUARD dialogue by selecting "TailGUARD" or TailGUARD light" from the "Measured values" menu.</li> <li>• In the TailGUARD dialogue, click the "Start initial start-up" button.</li> <li>• Follow the instructions on the screen.</li> <li>• WABCO part number for ultrasonic sensors: 446 122 450 0 LIN ultrasonic sensor, 1.0°, 3m cable length, not preconfigured - this sensor is used for TailGUARD light or for TailGUARD in all positions.</li> </ul>

Fault Code	Suspect Component and Location	Description	Cause	Repair Information
33884.12	Ultrasonic sensor LIN 2 (main level Right)	Sensor Failure	The ultrasonic sensor 2 (main level Right) has an internal fault	<ul style="list-style-type: none"> <li>• If this fault occurs frequently, replace the sensor.</li> <li>• If the ultrasonic sensor needs to be replaced, proceed as follows:               <ul style="list-style-type: none"> <li>• Remove the sensor and disconnect the plug connection of the sensor cable.</li> <li>• Install the new sensor 446 122 450 0 and connect it.</li> <li>• Start the TailGUARD Diagnostic Software via TOOLBOX. Note: A sensor may still be indicated as defective after it has been replaced; other sensors may now also be reported as defective in the fault memory. The reason for this is that the sensors need to be newly assigned after a sensor has been replaced. There is no new defect!</li> <li>• This step is optional, but may simplify the subsequent start-up procedure for the system: Select the "Settings" menu item from the "Options" menu and the "Test options" tab in the settings dialogue. In the "TailGUARD (FAS/RMS) test" group, deactivate the "Direct Echo Test (optional)" checkboxes as well as "Object test (optional)". This enables skipping the reflection test and the object detection test during start-up, thereby reducing the time required for the repair. Attention: This option should only be deactivated for the replacement of ultrasonic sensors in vehicles that have already been put into operation and should be reactivated after the repair. For the initial start-up after installation of a TailGUARD system, the option should be activated.</li> <li>• A new start-up procedure for the entire vehicle is not necessary. Only the TailGUARD function must be started up. Open the TailGUARD dialogue by selecting "TailGUARD" or TailGUARD light" from the "Measured values" menu.</li> <li>• In the TailGUARD dialogue, click the "Start initial start-up" button.</li> <li>• Follow the instructions on the screen.</li> <li>• WABCO part number for ultrasonic sensors: 446 122 450 0 LIN ultrasonic sensor, 1 0°, 3m cable length, not preconfigured - this sensor is used for TailGUARD light or for TailGUARD in all positions.</li> </ul> </li> </ul>

Fault Code	Suspect Component and Location	Description	Cause	Repair Information
33900.12	Ultrasonic sensor LIN 2 (main level Right)	Sensor Failure	The ultrasonic sensor 2 (main level Right) is dirty or has a sensor membrane fault	<ul style="list-style-type: none"> <li>• Make sure that the sensor membrane is clean and the sensor has free view. If this fault occurs permanently, replace the sensor.</li> <li>• If the ultrasonic sensor needs to be replaced, proceed as follows:               <ul style="list-style-type: none"> <li>• Remove the sensor and disconnect the plug connection of the sensor cable.</li> <li>• Install the new sensor 446 122 450 0 and connect it.</li> <li>• Start the TailGUARD Diagnostic Software via TOOLBOX. Note: A sensor may still be indicated as defective after it has been replaced; other sensors may now also be reported as defective in the fault memory. The reason for this is that the sensors need to be newly assigned after a sensor has been replaced. There is no new defect!</li> <li>• This step is optional, but may simplify the subsequent start-up procedure for the system: Select the "Settings" menu item from the "Options" menu and the "Test options" tab in the settings dialogue. In the "TailGUARD (RAS/RMS) test" group, deactivate the "Direct Echo Test (optional)" checkboxes as well as "Object test (optional)". This enables skipping the reflection test and the object detection test during start-up, thereby reducing the time required for the repair. Attention: This option should only be deactivated for the replacement of ultrasonic sensors in vehicles that have already been put into operation and should be reactivated after the repair. For the initial start-up after installation of a TailGUARD system, the option should be activated.</li> <li>• A new start-up procedure for the entire vehicle is not necessary. Only the TailGUARD function must be started up. Open the TailGUARD dialogue by selecting "TailGUARD" or TailGUARD light" from the "Measured values" menu.</li> <li>• In the TailGUARD dialogue, click the "Start initial start-up" button.</li> <li>• Follow the instructions on the screen.</li> <li>• WABCO part number for ultrasonic sensors: 446 122 450 0 LIN ultrasonic sensor; 1 0° , 3m cable length, not preconfigured - this sensor is used for TailGUARD light or for TailGUARD in all positions.</li> </ul> </li> </ul>

Fault Code	Suspect Component and Location	Description	Cause	Repair Information
33909.05	Ultrasonic sensor LIN 2 (main level Right)	Break in supply cable	The cable to the ultrasonic sensor 2 (main level Right) is interrupted or the new ultrasonic sensor has not yet been learned	<ul style="list-style-type: none"> <li>• If the fault occurs within the TailGUARD start-up procedure, ignore fault and repeat start-up procedure.</li> <li>• If the ultrasonic sensor needs to be replaced, proceed as follows:               <ul style="list-style-type: none"> <li>• Remove the sensor and disconnect the plug connection of the sensor cable.</li> <li>• Install the new sensor 446 122 450 0 and connect it.</li> <li>• Start the TailGUARD Diagnostic Software via TOOLBOX. Note: A sensor may still be indicated as defective after it has been replaced; other sensors may now also be reported as defective in the fault memory. The reason for this is that the sensors need to be newly assigned after a sensor has been replaced. There is no new defect!</li> <li>• This step is optional, but may simplify the subsequent start-up procedure for the system: Select the "Settings" menu item from the "Options" menu and the "Test options" tab in the settings dialogue. In the "TailGUARD (RAS/RMS) test" group, deactivate the "Direct Echo Test (optional)" checkboxes as well as "Object test (optional)". This enables skipping the reflection test and the object detection test during start-up, thereby reducing the time required for the repair. Attention: This option should only be deactivated for the replacement of ultrasonic sensors in vehicles that have already been put into operation and should be reactivated after the repair. For the initial start-up after installation of a TailGUARD system, the option should be activated.</li> <li>• A new start-up procedure for the entire vehicle is not necessary. Only the TailGUARD function must be started up. Open the TailGUARD dialogue by selecting "TailGUARD" or TailGUARD light" from the "Measured values" menu.</li> <li>• In the TailGUARD dialogue, click the "Start initial start-up" button.</li> <li>• Follow the instructions on the screen.</li> <li>• WABCO part number for ultrasonic sensors: 446 122 450 0 LIN ultrasonic sensor, 1 0°, 3m cable length, not preconfigured - this sensor is used for TailGUARD light or for TailGUARD in all positions.</li> </ul> </li> </ul>

Fault Code	Suspect Component and Location	Description	Cause	Repair Information
34076.12	Ultrasonic sensor LIN 3 (main level Centre)	Sensor Failure	The ultrasonic sensor 3 (main level Centre) has an internal fault	<ul style="list-style-type: none"> <li>• If this fault occurs frequently, replace the sensor.</li> <li>• If the ultrasonic sensor needs to be replaced, proceed as follows:               <ul style="list-style-type: none"> <li>• Remove the sensor and disconnect the plug connection of the sensor cable.</li> <li>• Install the new sensor 446 122 450 0 and connect it.</li> </ul> </li> <li>• Start the TailGUARD Diagnostic Software via TOOLBOX. Note: A sensor may still be indicated as defective after it has been replaced; other sensors may now also be reported as defective in the fault memory. The reason for this is that the sensors need to be newly assigned after a sensor has been replaced. There is no new defect!</li> <li>• This step is optional, but may simplify the subsequent start-up procedure for the system: Select the "Settings" menu item from the "Options" menu and the "Test options" tab in the settings dialogue. In the "TailGUARD (RAS/RMS) test" group, deactivate the "Direct Echo Test (optional)" checkboxes as well as "Object test (optional)". This enables skipping the reflection test and the object detection test during start-up, thereby reducing the time required for the repair. Attention: This option should only be deactivated for the replacement of ultrasonic sensors in vehicles that have already been put into operation and should be reactivated after the repair. For the initial start-up after installation of a TailGUARD system, the option should be activated.</li> <li>• A new start-up procedure for the entire vehicle is not necessary. Only the TailGUARD function must be started up. Open the TailGUARD dialogue by selecting "TailGUARD" or TailGUARD light" from the "Measured values" menu.</li> <li>• In the TailGUARD dialogue, click the "Start initial start-up" button.</li> <li>• Follow the instructions on the screen.</li> <li>• WABCO part number for ultrasonic sensors: 446 122 450 0 LIN ultrasonic sensor, 1.0°, 3m cable length, not preconfigured - this sensor is used for TailGUARD light or for TailGUARD in all positions.</li> </ul>

Fault Code	Suspect Component and Location	Description	Cause	Repair Information
34092.12	Ultrasonic sensor LIN 3 (main level Centre)	Sensor Failure	The ultrasonic sensor 3 (main level Centre) is dirty or has a sensor membrane fault	<ul style="list-style-type: none"> <li>• Make sure that the sensor membrane is clean and the sensor has free view. If this fault occurs permanently, replace the sensor.</li> <li>• If the ultrasonic sensor needs to be replaced, proceed as follows:               <ul style="list-style-type: none"> <li>• Remove the sensor and disconnect the plug connection of the sensor cable.</li> <li>• Install the new sensor 446 122 450 0 and connect it.</li> <li>• Start the TailGUARD Diagnostic Software via TOOLBOX. Note: A sensor may still be indicated as defective after it has been replaced; other sensors may now also be reported as defective in the fault memory. The reason for this is that the sensors need to be newly assigned after a sensor has been replaced. There is no new defect!</li> <li>• This step is optional, but may simplify the subsequent start-up procedure for the system: Select the "Settings" menu item from the "Options" menu and the "Test options" tab in the settings dialogue. In the "TailGUARD (RAS/RMS) test" group, deactivate the "Direct Echo Test (optional)" checkboxes as well as "Object test (optional)". This enables skipping the reflection test and the object detection test during start-up, thereby reducing the time required for the repair. Attention: This option should only be deactivated for the replacement of ultrasonic sensors in vehicles that have already been put into operation and should be reactivated after the repair. For the initial start-up after installation of a TailGUARD system, the option should be activated.</li> <li>• A new start-up procedure for the entire vehicle is not necessary. Only the TailGUARD function must be started up. Open the TailGUARD dialogue by selecting "TailGUARD" or TailGUARD light" from the "Measured values" menu.</li> <li>• In the TailGUARD dialogue, click the "Start initial start-up" button.</li> <li>• Follow the instructions on the screen.</li> <li>• WABCO part number for ultrasonic sensors: 446 122 450 0 LIN ultrasonic sensor, 1 0°, 3m cable length, not preconfigured - this sensor is used for TailGUARD light or for TailGUARD in all positions."</li> </ul> </li> </ul>



Fault Code	Suspect Component and Location	Description	Cause	Repair Information
34096.00	Ultrasonic sensor LIN 3 (main level Centre)	Sensor Failure	The ultrasonic sensor 3 (main level Centre) has an internal fault	<ul style="list-style-type: none"> <li>• If this fault occurs frequently, replace the sensor.</li> <li>• If the ultrasonic sensor needs to be replaced, proceed as follows:               <ul style="list-style-type: none"> <li>• Remove the sensor and disconnect the plug connection of the sensor cable.</li> <li>• Install the new sensor 446 122 450 0 and connect it.</li> <li>• Start the TailGUARD Diagnostic Software via TOOLBOX. Note: A sensor may still be indicated as defective after it has been replaced; other sensors may now also be reported as defective in the fault memory. The reason for this is that the sensors need to be newly assigned after a sensor has been replaced. There is no new defect!</li> </ul> </li> <li>• This step is optional, but may simplify the subsequent start-up procedure for the system: Select the "Settings" menu item from the "Options" menu and the "Test options" tab in the settings dialogue. In the "TailGUARD (RAS/RMS) test" group, deactivate the "Direct Echo Test (optional)" checkboxes as well as "Object test (optional)". This enables skipping the reflection test and the object detection test during start-up, thereby reducing the time required for the repair. Attention: This option should only be deactivated for the replacement of ultrasonic sensors in vehicles that have already been put into operation and should be reactivated after the repair. For the initial start-up after installation of a TailGUARD system, the option should be activated.</li> <li>• A new start-up procedure for the entire vehicle is not necessary. Only the TailGUARD function must be started up. Open the TailGUARD dialogue by selecting "TailGUARD" or TailGUARD light" from the "Measured values" menu.</li> <li>• In the TailGUARD dialogue, click the "Start initial start-up" button.</li> <li>• Follow the instructions on the screen</li> <li>• WABCO part number for ultrasonic sensors: 446 122 450 0 LIN ultrasonic sensor, 1.0°, 3m cable length, not preconfigured - this sensor is used for TailGUARD light or for TailGUARD in all positions.</li> </ul>



Fault Code	Suspect Component and Location	Description	Cause	Repair Information
34124.12	Ultrasonic sensor LIN 3 (main level Centre)	Sensor Failure	The ultrasonic sensor 3 (main level Centre) has an internal fault	<ul style="list-style-type: none"> <li>• If this fault occurs frequently, replace the sensor.</li> <li>• If the ultrasonic sensor needs to be replaced, proceed as follows:               <ul style="list-style-type: none"> <li>• Remove the sensor and disconnect the plug connection of the sensor cable.</li> <li>• Install the new sensor 446 122 450 0 and connect it.</li> </ul> </li> <li>• Start the TailGUARD Diagnostic Software via TOOLBOX. Note: A sensor may still be indicated as defective after it has been replaced; other sensors may now also be reported as defective in the fault memory. The reason for this is that the sensors need to be newly assigned after a sensor has been replaced. There is no new defect!</li> <li>• This step is optional, but may simplify the subsequent start-up procedure for the system: Select the "Settings" menu item from the "Options" menu and the "Test options" tab in the settings dialogue. In the "TailGUARD (RAS/RMS) test" group, deactivate the "Direct Echo Test (optional)" checkboxes as well as "Object test (optional)". This enables skipping the reflection test and the object detection test during start-up, thereby reducing the time required for the repair. Attention: This option should only be deactivated for the replacement of ultrasonic sensors in vehicles that have already been put into operation and should be reactivated after the repair. For the initial start-up after installation of a TailGUARD system, the option should be activated.</li> <li>• A new start-up procedure for the entire vehicle is not necessary. Only the TailGUARD function must be started up. Open the TailGUARD dialogue by selecting "TailGUARD" or TailGUARD light" from the "Measured values" menu.</li> <li>• In the TailGUARD dialogue, click the "Start initial start-up" button.</li> <li>• Follow the instructions on the screen.</li> <li>• WABCO part number for ultrasonic sensors: 446 122 450 0 LIN ultrasonic sensor, 1.0°, 3m cable length, not preconfigured - this sensor is used for TailGUARD light or for TailGUARD in all positions.</li> </ul>

Fault Code	Suspect Component and Location	Description	Cause	Repair Information
34140.12	Ultrasonic sensor LIN 3 (main level Centre)	Sensor Failure	The ultrasonic sensor 3 (main level Centre) has an internal fault	<ul style="list-style-type: none"> <li>• If this fault occurs frequently, replace the sensor.</li> <li>• If the ultrasonic sensor needs to be replaced, proceed as follows:               <ul style="list-style-type: none"> <li>• Remove the sensor and disconnect the plug connection of the sensor cable.</li> <li>• Install the new sensor 446 122 450 0 and connect it.</li> </ul> </li> <li>• Start the TailGUARD Diagnostic Software via TOOLBOX. Note: A sensor may still be indicated as defective after it has been replaced; other sensors may now also be reported as defective in the fault memory. The reason for this is that the sensors need to be newly assigned after a sensor has been replaced. There is no new defect!</li> <li>• This step is optional, but may simplify the subsequent start-up procedure for the system: Select the "Settings" menu item from the "Options" menu and the "Test options" tab in the settings dialogue. In the "TailGUARD (RAS/RMS) test" group, deactivate the "Direct Echo Test (optional)" checkboxes as well as "Object test (optional)". This enables skipping the reflection test and the object detection test during start-up, thereby reducing the time required for the repair. Attention: This option should only be deactivated for the replacement of ultrasonic sensors in vehicles that have already been put into operation and should be reactivated after the repair. For the initial start-up after installation of a TailGUARD system, the option should be activated.</li> <li>• A new start-up procedure for the entire vehicle is not necessary. Only the TailGUARD function must be started up. Open the TailGUARD dialogue by selecting "TailGUARD" or TailGUARD light" from the "Measured values" menu.</li> <li>• In the TailGUARD dialogue, click the "Start initial start-up" button.</li> <li>• Follow the instructions on the screen.</li> <li>• WABCO part number for ultrasonic sensors: 446 122 450 0 LIN ultrasonic sensor, 1 0°, 3m cable length, not preconfigured - this sensor is used for TailGUARD light or for TailGUARD in all positions.</li> </ul>

Fault Code	Suspect Component and Location	Description	Cause	Repair Information
34156.12	Ultrasonic sensor LIN 3 (main level Centre)	Sensor Failure	The ultrasonic sensor 3 (main level Centre) is dirty or has a sensor membrane fault	<ul style="list-style-type: none"> <li>• Make sure that the sensor membrane is clean and the sensor has free view. If this fault occurs permanently, replace the sensor.</li> <li>• If the ultrasonic sensor needs to be replaced, proceed as follows:               <ul style="list-style-type: none"> <li>• Remove the sensor and disconnect the plug connection of the sensor cable.</li> <li>• Install the new sensor 446 122 450 0 and connect it.</li> <li>• Start the TailGUARD Diagnostic Software via TOOLBOX. Note: A sensor may still be indicated as defective after it has been replaced; other sensors may now also be reported as defective in the fault memory. The reason for this is that the sensors need to be newly assigned after a sensor has been replaced. There is no new defect!</li> <li>• This step is optional, but may simplify the subsequent start-up procedure for the system: Select the "Settings" menu item from the "Options" menu and the "Test options" tab in the settings dialogue. In the "TailGUARD (RAS/RMS) test" group, deactivate the "Direct Echo Test (optional)" checkboxes as well as "Object test (optional)". This enables skipping the reflection test and the object detection test during start-up, thereby reducing the time required for the repair. Attention: This option should only be deactivated for the replacement of ultrasonic sensors in vehicles that have already been put into operation and should be reactivated after the repair. For the initial start-up after installation of a TailGUARD system, the option should be activated.</li> <li>• A new start-up procedure for the entire vehicle is not necessary. Only the TailGUARD function must be started up. Open the TailGUARD dialogue by selecting "TailGUARD" or TailGUARD light" from the "Measured values" menu.</li> <li>• In the TailGUARD dialogue, click the "Start initial start-up" button.</li> <li>• Follow the instructions on the screen.</li> <li>• WABCO part number for ultrasonic sensors: 446 122 450 0 LIN ultrasonic sensor, 1 0°, 3m cable length, not preconfigured - this sensor is used for TailGUARD light or for TailGUARD in all positions.</li> </ul> </li> </ul>

Fault Code	Suspect Component and Location	Description	Cause	Repair Information
34165.05	Ultrasonic sensor LIN 3 (main level Centre)	Break in supply cable	The cable to the ultrasonic sensor 3 (main level Centre) is interrupted or the new ultrasonic sensor has not yet been learned	<ul style="list-style-type: none"> <li>• If the fault occurs within the TailGUARD start-up procedure, ignore fault and repeat start-up procedure.</li> <li>• If the ultrasonic sensor needs to be replaced, proceed as follows:               <ul style="list-style-type: none"> <li>• Remove the sensor and disconnect the plug connection of the sensor cable.</li> <li>• Install the new sensor 446 122 450 0 and connect it.</li> <li>• Start the TailGUARD Diagnostic Software via TOOLBOX. Note: A sensor may still be indicated as defective after it has been replaced; other sensors may now also be reported as defective in the fault memory. The reason for this is that the sensors need to be newly assigned after a sensor has been replaced. There is no new defect!</li> <li>• This step is optional, but may simplify the subsequent start-up procedure for the system: Select the "Settings" menu item from the "Options" menu and the "Test options" tab in the settings dialogue. In the "TailGUARD (RAS/RMS) test" group, deactivate the "Direct Echo Test (optional)" checkboxes as well as "Object test (optional)". This enables skipping the reflection test and the object detection test during start-up, thereby reducing the time required for the repair. Attention: This option should only be deactivated for the replacement of ultrasonic sensors in vehicles that have already been put into operation and should be reactivated after the repair. For the initial start-up after installation of a TailGUARD system, the option should be activated.</li> <li>• A new start-up procedure for the entire vehicle is not necessary. Only the TailGUARD function must be started up. Open the TailGUARD dialogue by selecting "TailGUARD" or TailGUARD light" from the "Measured values" menu.</li> <li>• In the TailGUARD dialogue, click the "Start initial start-up" button.</li> <li>• Follow the instructions on the screen.</li> <li>• WABCO part number for ultrasonic sensors: 446 122 450 0 LIN ultrasonic sensor, 1 0°, 3m cable length, not preconfigured - this sensor is used for TailGUARD light or for TailGUARD in all positions.</li> </ul> </li> </ul>

# Component Replacement

## 8 Component Replacement

### 8.1 Component Removal and Installation Procedures

Observe the following hazard alert messages when performing component replacement procedures.

#### **WARNING**

To prevent serious eye injury, always wear safe eye protection when you perform vehicle maintenance or service.

#### **WARNING**

Park the vehicle on a level surface. Block the wheels to prevent the vehicle from moving. Support the vehicle with safety stands. Do not work under a vehicle supported only by jacks. Jacks can slip and fall over. Serious personal injury and damage to components can result.

#### **WARNING**

The ABS is an electrical system. When you work on the ABS, take the same precautions that you must take with any electrical system to avoid serious personal injury. As with any electrical system, the danger of electrical shock or sparks exists that can ignite flammable substances. You must always disconnect the battery ground cable before working on the electrical system.

#### **CAUTION**

When welding on an ABS-equipped vehicle is necessary, disconnect the power connector from the ECU to avoid damage to the electrical system and ABS components.

#### **CAUTION**

High voltages can damage the electronic control unit (ECU). Disconnect all connectors from the ECU before you perform any welding, electrostatic painting, or any other activity that applies high voltage to the vehicle frame. Install blind plugs into the ECU to protect the connector openings. Ground the welding or painting equipment to the part you are working on. If you are working on a moving or insulated component such as an axle, make sure it is correctly grounded through the frame. Refer to the equipment manufacturer's recommended instructions for correct procedures.

#### **NOTICE**

Disconnect power from the ECU/Valve Assembly before you remove any components. Failure to disconnect power from the ECU can cause faults to be recorded and stored in ECU memory.

# Component Replacement

## 8.2 Cable Connections

All cables connecting to the RSS*plus*™ ECU are secured by means of a yellow locking connector. These connectors slide forward and back in order to lock or release the cable at the ECU. Use a small open-ended wrench to lever the locking connector into the open position. Once an existing cable has been replaced or a new cable installed on an original installation, the connector can be pushed back into the locked position by hand, securely anchoring the cable connection to the ECU. If correctly installed, the use of di-electric grease is not necessary.

## 8.3 Wheel Speed Sensor

### 8.3.1 Remove the Old Sensor

1. Follow the vehicle manufacturer's instructions to back off the slack adjuster and remove the tire, wheel and drum.
2. Hold the sensor, not the cable, and use a twisting motion to pull the sensor out of its sensor holder.
3. Remove the spring clip from the sensor holder.
4. Remove any fasteners that hold the sensor cable to other components.
5. Disconnect the sensor cable from the extension cable.

### 8.3.2 Install the New Sensor

Sensor locations vary according to suspension types. Typically, a spring suspension has sensors on the forward axle, and an air suspension has sensors on the rear axle.

1. Apply a mineral oil-based grease that contains molydisulfide to the sensor spring clip and to the body of the sensor. The grease must be anti-corrosive and contain adhesive properties that will continuously endure temperatures from -40° to 300°F (-40° to 150°C).
2. Push the spring clip into the sensor holder from the inboard side, until the spring clip tabs are against the sensor holder. Push the sensor into the spring clip as far as possible.

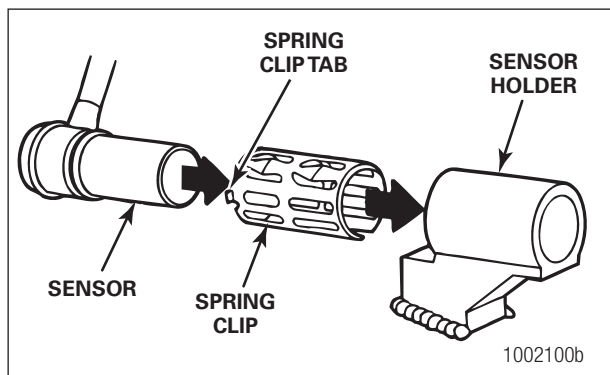

## Component Replacement

3. Route the sensor cable toward the brake chamber, over the brake spider, and behind the axle. Secure the cable to the axle between the brake spider and the suspension brackets. Continue to route the sensor cable behind the spring seats. Secure the cable to the axle one inch from the molded sensor plug.

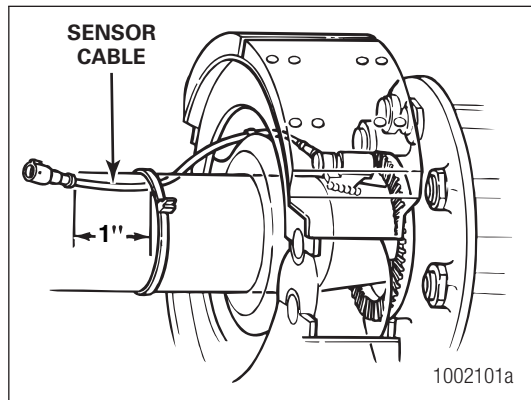

4. Install the wheel hub carefully, so that the tooth wheel pushes against the sensor as you adjust the wheel bearings. After installation there should be no gap between the sensor and the tooth wheel. During normal operation a gap of 0.040-inch is allowable.
5. **Sensor Output Voltage Test:** Use a volt/ohm meter to check the AC output voltage of the sensors while rotating the wheel at approximately one-half revolution per second. Minimum output must be greater than 0.2 volts AC. If minimum output is less than 0.2 volts AC, push the sensor toward the tooth wheel. Recheck the sensor output.

## 8.4 ECU/Valve Assembly

### WARNING

Release all pressure from the air system before you disconnect any components. Pressurized air can cause serious personal injury.

### 8.4.1 Remove the Old ECU/Valve Assembly

1. Release all pressure from the air system.
2. Attach labels to identify all air lines.
3. Disconnect the air lines from the ECU/Valve Assembly.
4. Disconnect the power cable, additional relay valve cable (if used), and all sensor cables from the ECU/Valve Assembly.
5. Remove the ECU/Valve Assembly from its mounting location.

# Component Replacement

Loosen and remove the two mounting bolts and lock nuts that hold the assembly to the cross member or bracket. Remove the assembly.

6. If the assembly being replaced is under warranty, please return it to the trailer OEM for replacement.

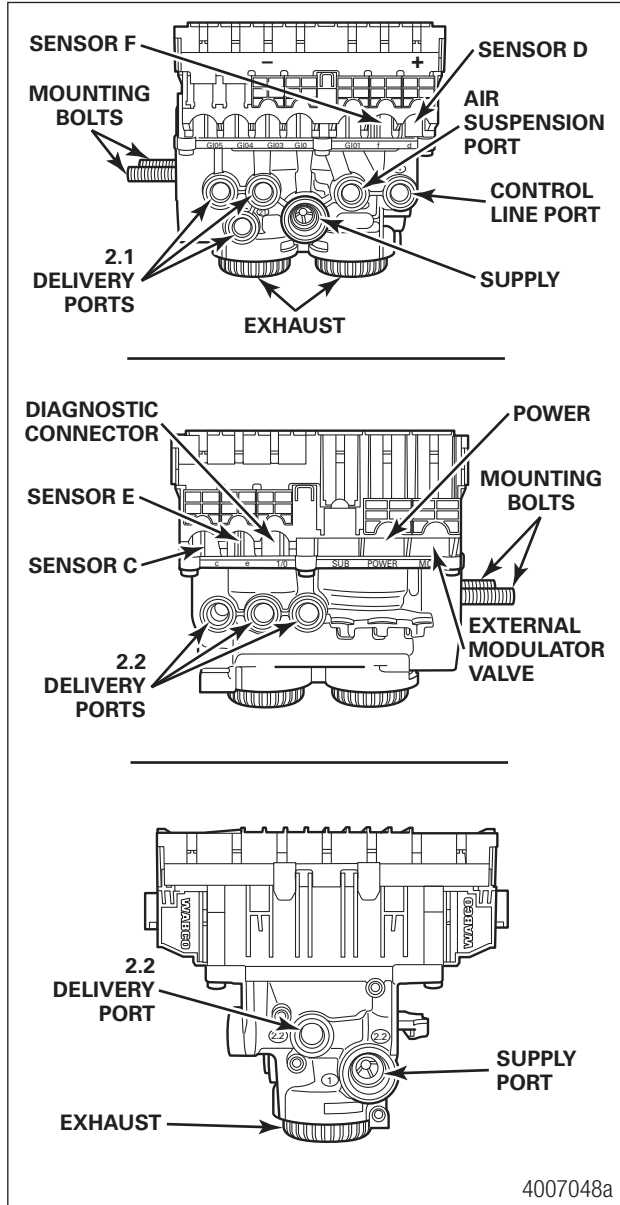

## 8.4.2 Install the New ECU/Valve Assembly

### NOTICE

When a sensor cable is not plugged into a sensor connector, the black cap must remain in the connector to protect it from dirt and contamination. Figure 8.3.



The ECU/Valve Assembly is supplied with black protective caps in each sensor connector.



## Component Replacement

### 8.4.3 Mounting RSSplus™ ECU to Cross Member of Vehicle — Bracket Not Supplied

When mounting the ECU/dual modulator valve assembly to the trailer cross member, refer to SAE specification J447, Prevention of Corrosion of Motor Vehicle Body and Chassis Components. Follow all recommendations and procedures. Your supervisor should have a copy of this specification.

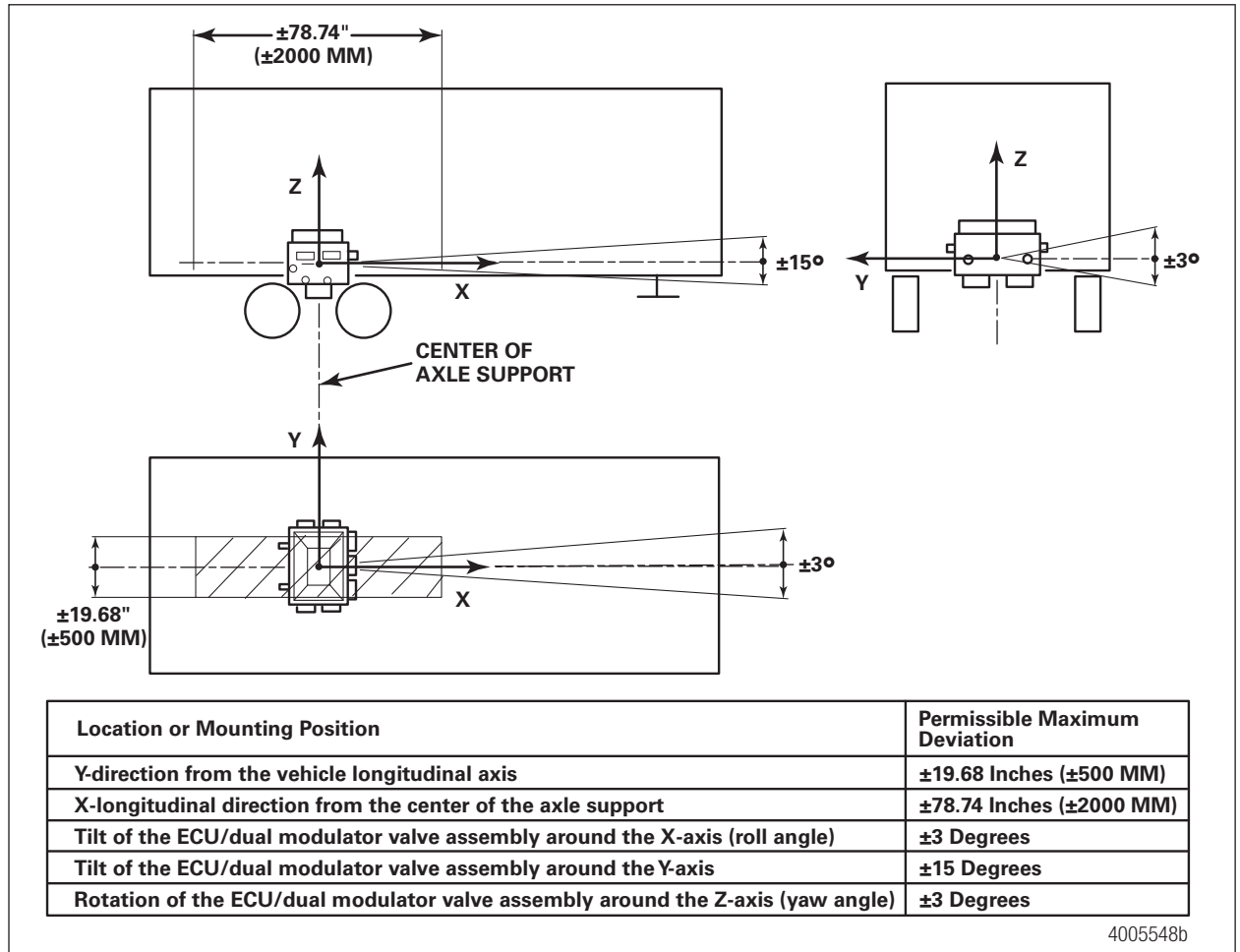

#### Preparation

Before beginning the installation procedure, perform the following.

Inspect the ECU/dual modulator valve assembly for damage that may have occurred during shipping or storage.

- Look for crushed or bent connectors.
- Verify that the retainer clips have not been bent or otherwise damaged.
- Do not install a damaged ECU/dual modulator valve assembly. Notify your supervisor, or contact WABCO if there is any apparent damage.

# Component Replacement

## 8.5 ECU/Dual Modulator Valve Assembly

### **⚠ CAUTION**

The replacement ECU assembly may not be mounted on an air tank. An air tank will not support the weight of the ECU/dual modulator valve assembly. A bracket may be fabricated using steel at least 3/16-inch (5 mm) thick or mounted directly to the cross member.

**RSS will not function correctly if the mounting location does not meet the following requirements.**

To complete the RSS*plus*™ replacement, you must have 120 psi air pressure available. A 12-volt DC (10 amp minimum) power supply must also be available.

- The ECU assembly must be mounted level onto a rigid structure of the subframe and must be mounted facing either the front or the rear of the trailer.
- Mount the ECU/dual modulator valve assembly in the center width of the trailer subframe, midway between the axle spacing.
- Do not mount to an air tank.
- Do not mount sideways. The ECU mounting bolts must point toward either the front or the rear of the trailer.



There are no recesses permissible next to contact face.

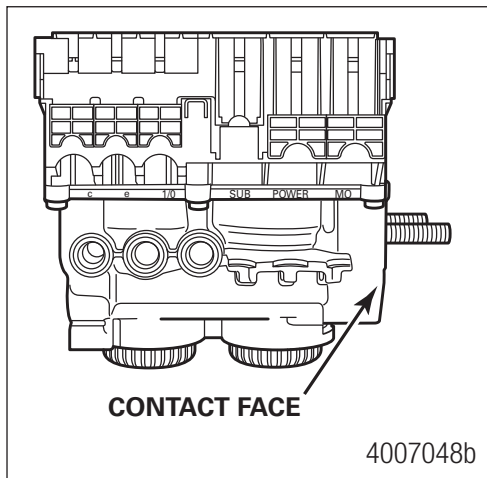

### 8.5.1 Installation Procedure

1. Apply SAE-standard, DOT-approved paste-type thread sealant to all NPTF threads. Do not use excessive amounts of sealant.
  - Supply ports are 3/4-inch NPTF.
  - Delivery control and air suspension ports are 3/8-inch NPTF.

## Component Replacement

2. Mount the assembly level to a rigid structure of the subframe midway between the side rails, close to the brake chambers the valve serves.

- Attach to the cross member. The center-to-center distance between the two holes must be 2-3/4-inches (70 mm) and mount directly to a rigid structure.

OR

- Attach to a mounting bracket with two 9/16-inch (14 mm) mounting holes with 2-3/4-inches (70 mm) center-to-center distance between the two holes. The bracket must be made of cold rolled 1040 to 1080 steel with a reinforcing gusset.

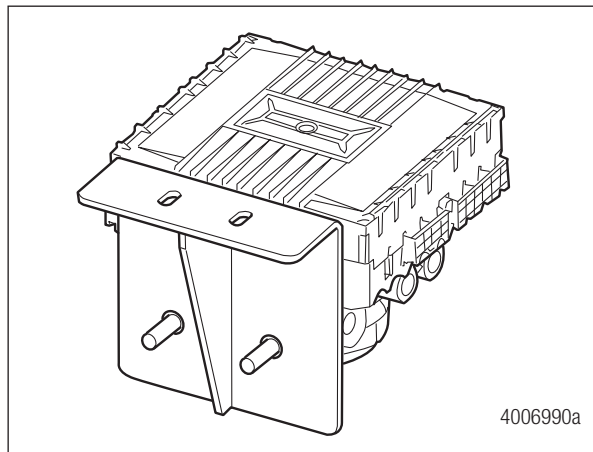
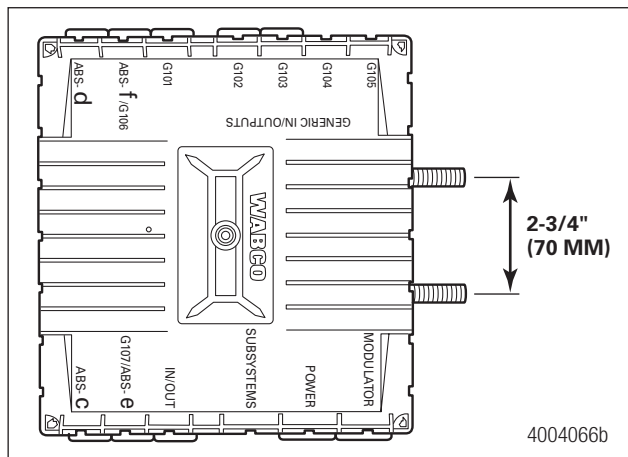

3. Use two 1/2-inch nuts to attach to the integral bolts. Tighten the nuts to 62 ft-lb (85 Nm).
4. For additional corrosion protection, the ECU/dual modulator assembly may be painted. Mask the exhaust ports before painting. Remove the masking after painting.
5. Washers or spring lock washers are only permitted directly under the nut.
6. The bracket or mounting area must completely cover the bearing surface of the mounting flange.

# Component Replacement

## 8.6 Air Lines

1. Connect the air supply line from the supply tank to the 3/4-inch NPTF supply port on the ECU/dual modulator valve assembly. **Use 5/8-inch minimum O.D. nylon tubing.**
2. Connect air delivery lines to the ECU valve assembly. The ports labeled 2.1 and 2.2 are 3/8-inch NPTF. Refer to Figure 8.3 for ECU valve port assignments, and Section 6 for air line configuration.

## 8.7 Distance Sensor

The Distance Sensor is used only with Roll Stability equipped trailers that have mechanical (spring) suspensions. Trailers equipped with air suspensions do not use a Distance Sensor with their *RSSplus™* system.

The Distance Sensor is attached to the trailer structure or cross member. In some cases, the trailer OEM may have it attached to a fabricated bracket.

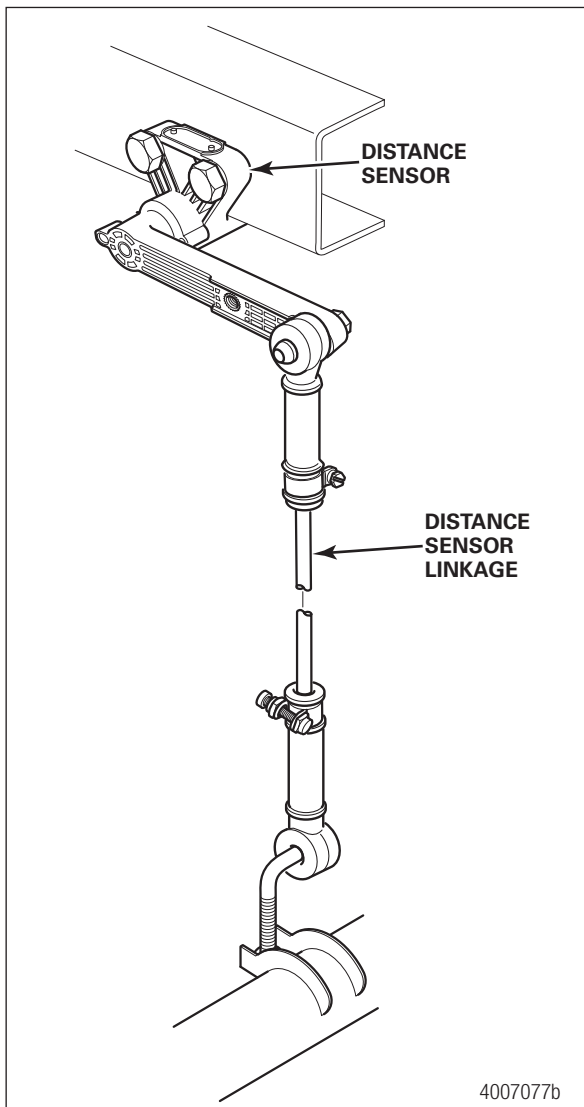

# Component Replacement

## 8.7.1 Remove the Old Distance Sensor

1. Disconnect the cable attached to the Distance Sensor.

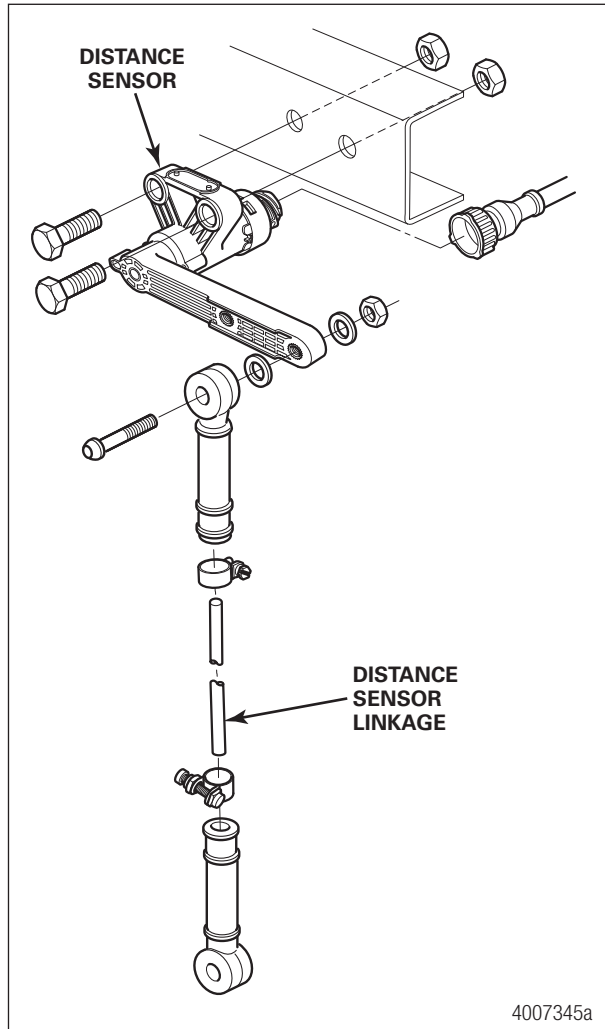

2. Remove the bolt that attaches the Distance Sensor Lever to the Distance Sensor arm.
3. Remove the two bolts that attach the Distance Sensor to the cross member or bracket.
4. Remove the Distance Sensor.

## 8.7.2 Install the New Distance Sensor

1. Install the Distance Sensor to the cross member or bracket near the center of the trailer with the two bolts previously used to mount the replaced sensor.
2. Attach the Distance Sensor Lever to the Distance Sensor arm. Use both threaded holes on the sensor arm to attach the distance sensor lever.
3. Connect the Distance Sensor cable.
4. Once the Distance Sensor has been replaced, it must be calibrated before putting the trailer back into service. Refer to Section 9 for Distance Sensor Calibration.

# Component Replacement

## 8.8 Distance Sensor Extension Lever

Some trailers experience jounce due to certain spring suspensions' characteristics and require an extension of the distance sensor. This extension lever (part number 441 901 715 4) allows the lever length parameter in the TOOLBOX™ Software to be set to 150 mm. Mounting hardware for the extension lever is found in the linkage kit (part number 105 100 002 0).

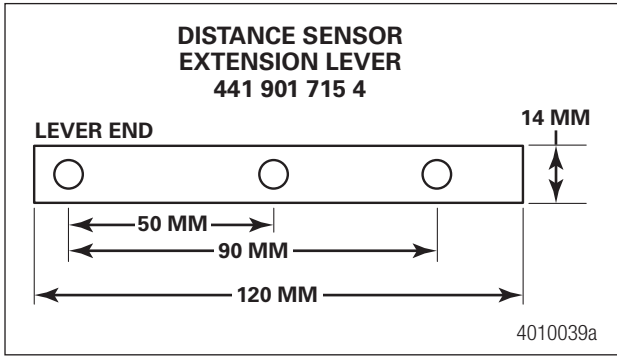

# Sensor Adjustment and Component Testing

## 9 Sensor Adjustment and Component Testing

Observe the following hazard alert messages when performing adjustment and testing procedures.

### **WARNING**

To prevent serious eye injury, always wear safe eye protection when you perform vehicle maintenance or service.

### **WARNING**

Park the vehicle on a level surface. Block the wheels to prevent the vehicle from moving. Support the vehicle with safety stands. Do not work under a vehicle supported only by jacks. Jacks can slip and fall over. Serious personal injury and damage to components can result.

### **WARNING**

The ABS is an electrical system. When you work on the ABS, take the same precautions that you must take with any electrical system to avoid serious personal injury. As with any electrical system, the danger of electrical shock or sparks exists that can ignite flammable substances. You must always disconnect the battery ground cable before working on the electrical system.

### **NOTICE**

Disconnect power from the ECU/Valve Assembly before you remove any components. Failure to disconnect power from the ECU can cause faults to be recorded and stored in ECU memory.

## 9.1 Testing

### 9.1.1 Testing the Wheel Speed Sensors



At initial installation, no gap must exist between the sensor and the tooth wheel.



After you install a hub, always check that the sensor is adjusted correctly.

Operating the trailer can cause a gap to develop between the sensor and the tooth wheel. If the gap exceeds 0.040-inch, the system may not function correctly.

To adjust the sensor, twist and push the sensor through the sensor bracket as far as possible or until the sensor touches the tooth wheel. There is no need for a feeler gauge as the sensor will correctly gap itself when the wheel rotates.

# Sensor Adjustment and Component Testing

## 9.1.1.1 Sensor Test Procedure

1. Disconnect power to the ECU/Valve Assembly.
2. Disconnect the sensor electrical connector from the ECU/Valve Assembly.
3. Connect the volt/ohm meter leads to the two wire rectangular terminals inside the disconnected connector.
4. When checking the resistance, the meter must read 900-2000 ohms.
5. Check and replace the sensor and cables as required.
6. Repeat Steps 1-5 for each sensor in the system.

## 9.1.2 Sensor Output Voltage Test

1. Disconnect power from the ECU/Valve Assembly.
2. Connect the AC volt/ohm meter leads to the sensor terminals inside the connector.
3. Rotate the corresponding wheel at a constant speed of one-half revolution per second.
4. The output voltage must be greater than 0.2 volts AC.
5. When there is no reading:
  - A. Trace the cable to verify that the cable connects to the wheel you turned.
  - B. Check that you turned the correct wheel.
  - C. Check that the system is wired correctly.
  - D. Check that the sensor touches the tooth wheel.
6. If the volt/ohm meter still indicates no reading or a low reading after following the above procedures, check and replace the component and cables as required.
7. Repeat Steps 1-5 for each sensor in the system.

## 9.2 Check ABS Functions

- WABCO requires that you test a vehicle's ABS after a new installation and after you diagnose, repair and erase faults in the ABS.
- Perform end of line check using TOOLBOX™ Software.

## 9.3 End of Line Testing

End of line testing is required on all RSS*plus*™ installations. To run these tests, WABCO requires you use TOOLBOX™ Software.

TOOLBOX™ Software and general test procedures are included in this manual. If you are using a Pro-Link, refer to the operating manual for test instructions.



# Sensor Adjustment and Component Testing

## 9.3.1 End of Line Testing Procedure Using TOOLBOX Software



Refer to TOOLBOX 12 Quick Start Guide TP99102 or for TOOLBOX Plus embedded User's Guide in TOOLBOX Plus Software.

1. Display the Trailer RSS Diagnostics Screen.
2. Verify power and air supply:
  - Apply 12 volts DC to the blue wire (constant). Check the screen for correct voltage (9.5 to 14 volts). Constant power voltage is displayed in the Primary field.
  - Power supply must have a 10 amp minimum.
  - Apply 120 psi to the red (supply) line of the trailer's air system. Be prepared to also apply 120 psi to the trailer's blue (control) line when directed.

## 9.4 Putting the Trailer into Service

### 9.4.1 Sign-Off Procedure (End of Line Testing)

Once installed, the WABCO RSS*plus*<sup>™</sup> system must go through a sign-off procedure. This ensures that the system has been correctly installed and the pneumatic functions of the trailer are supporting the Roll Stability ABS.

In order to run the sign-off procedure, the trailer must be connected to 12 volt DC power (10 amp minimum), be connected to supply air (120 psi), have the capability to have control line air applied, and have the sensed axles raised off the ground.

The following procedure can be performed immediately if the replacement ECU has been installed in the default configuration (4S/ 2M, air suspension, ECU facing forward). **If the ECU is installed in a non-default configuration, the ECU must be programmed before the sign-off procedure can be conducted. Refer to Section 10 for details.**

For mechanical suspensions, the vehicle parameters must be changed from the default settings. Parameter Entry guidelines can be found in Section 10.

All RSS*plus*<sup>™</sup> ECUs have 1:1 air delivery default settings. If trailer specific load proportioning is desired, please contact the WABCO Customer Care Center at 855-228-3203 for assistance. If no proportioning is desired, air pressures are left at the default settings. The administration of these parameters is covered in the Parameter Entry guidelines in Section 10.

# Sensor Adjustment and Component Testing

From the initial screen of the TOOLBOX™ Software, click on the RSSplus™ icon.

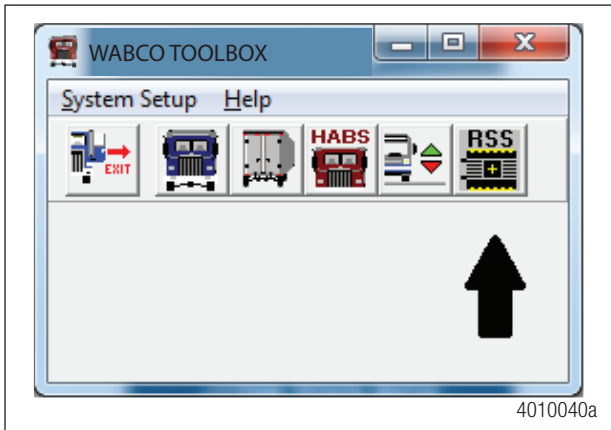

From the Main Screen, select Sign-Off from the pull-down menu bar. Then select Begin Sign-Off Procedure to begin the automated test procedure.

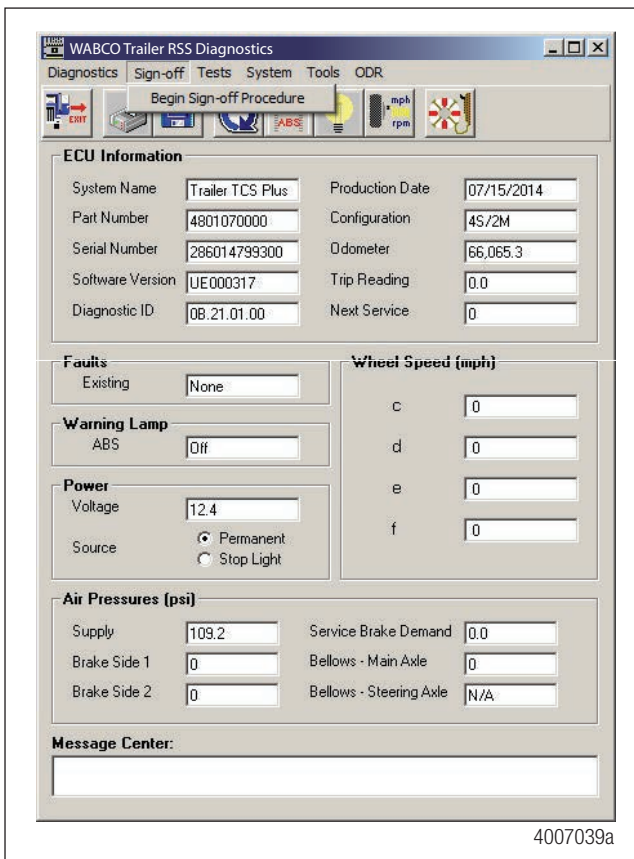

# Sensor Adjustment and Component Testing

## 9.4.2 The Pressure Test

This portion of the sign-off will check the ECU's internal modulator valves for correct operation. The test will begin automatically. Once the test successfully concludes, the sign-off procedure will automatically advance to the Redundancy Test. *There is no input needed from the tester.*

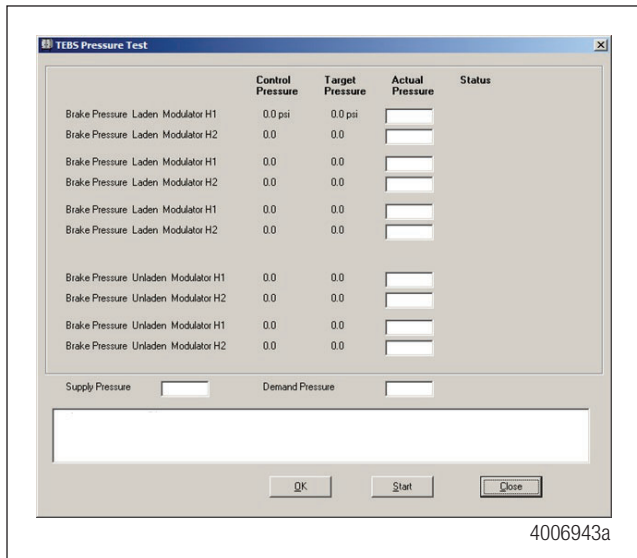

## 9.4.3 The Redundancy Test

This portion of the sign-off will check the pneumatic functionality of the trailer's air system to the RSS equipment. The Redundancy Test ensures the air capacity and control to the ECU is correct and measures the pressure at the internal modulator valves. The test will begin automatically. Apply control (blue) line air when prompted in the lower box. Once the test successfully concludes, the sign-off procedure will automatically advance to the Sensor Test.

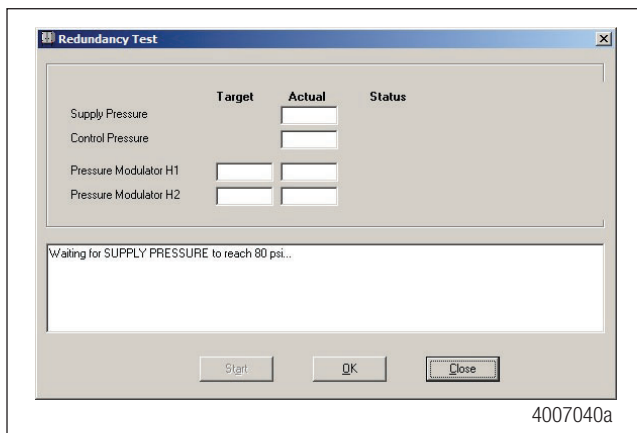

# Sensor Adjustment and Component Testing

## 9.4.4 The Sensor Test

This portion of the sign-off will check the placement of the ABS wheel sensors. Ensure there is no pressure on the control (blue) line and that the trailer has all ABS sensed axles up off the ground. The following message will appear. Press OK after all safety precautions have been taken and release the blue air line to begin the test.

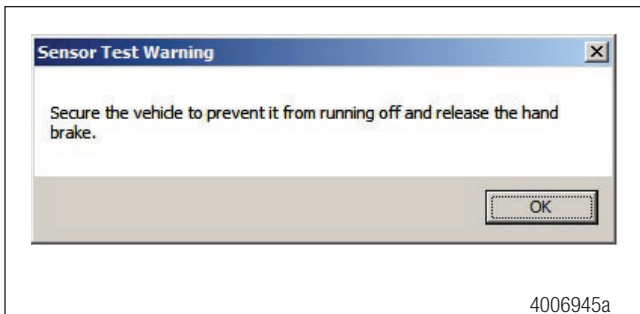

Rotate each wheel individually (in the order shown on the screen) and check the on-screen diagram to ensure correct sensor placement. **Errors will occur if the wheels are spun faster than 10 mph (16 kph).** Once the placement of all sensors has been correctly verified, the software will automatically advance to the Warning Lamp Test.

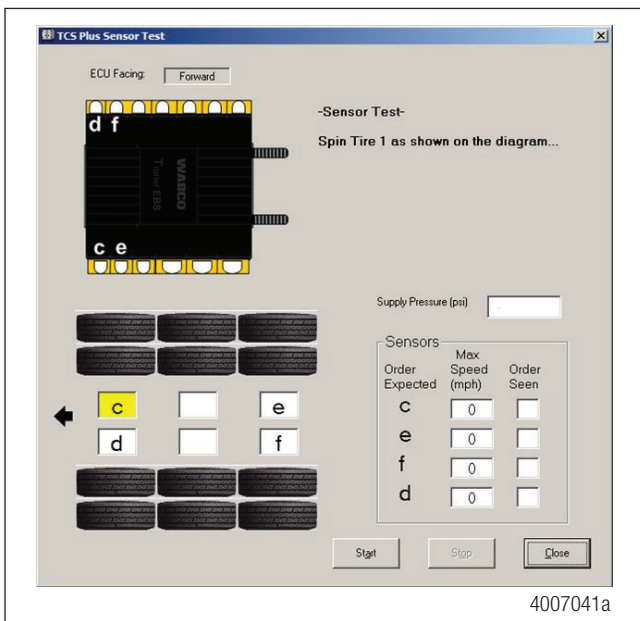

# Sensor Adjustment and Component Testing

## 9.4.5 The Warning Lamp Test

This portion of the sign-off will ensure correct operation of the ABS warning lamp. The warning light will flash on and off. Once correct operation is confirmed, press Yes.



## 9.4.6 Distance Sensor Calibration

If the trailer has a mechanical (spring) suspension, the distance sensor is calibrated next. Ensure that the trailer is lowered so that all wheels are fully on the ground before proceeding.

The Mechanical Suspension Calibration screen appears.

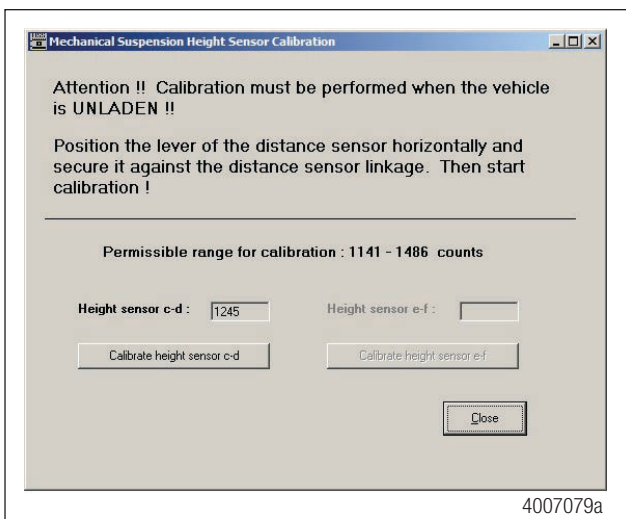

Ensure the Distance Sensor arm is parallel to the ground. The trailer must be in the unladen (empty) state. Once the value in the "Height Sensor" field no longer changes and is within the displayed acceptable range, press the button labeled Calibrate Height Sensor.

# Sensor Adjustment and Component Testing

A message appears that the calibration is successful. Press OK.

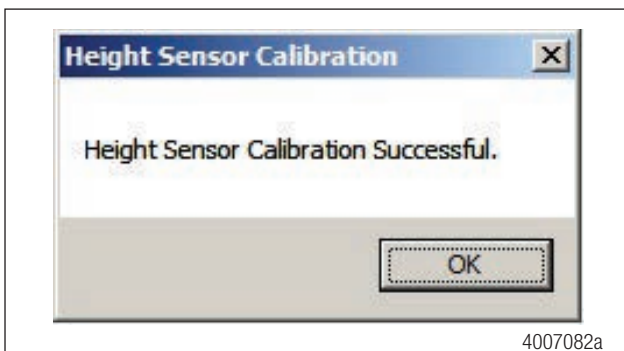
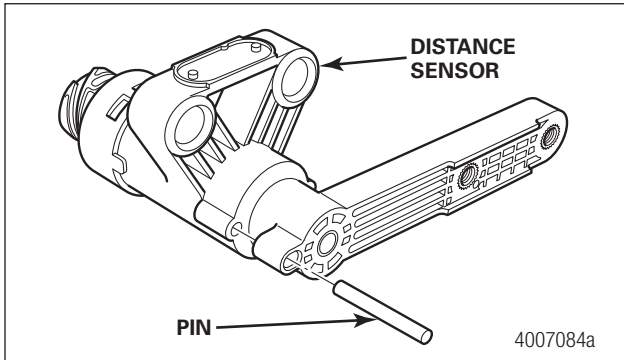

Successfully signing off the trailer will produce the confirmation screen and allow the tester the opportunity to save the results. Click on the Yes button and save the file in the appropriate data directory.

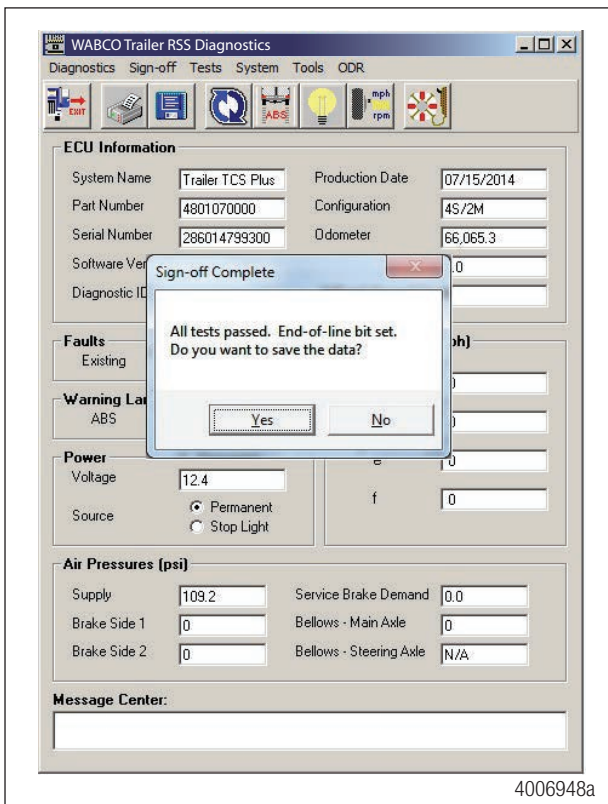

# Sensor Adjustment and Component Testing

A message appears confirming the file has been saved and shows the location of the data.



## 9.4.7 WABCO Customer Care Center

For additional assistance, contact the WABCO Customer Care Center at 855-228-3203.

Before calling the WABCO Customer Care Center, be prepared to provide the following information:

1. The trailer's original manufacturer and model year.
2. The SPECIFIC symptom or complaint.
3. What is the ABS blink code or TOOLBOX™ Software reading?
4. Have any resistance and/or voltage measurements been taken?
5. What is the result of visual inspection of connectors, harness and components?
6. When does the symptom occur (vehicle moving, fully loaded, etc.)?
7. Does the trailer have any unusual characteristics (for example, mismatched tires or larger than normal air consumption)?
8. What is the part number of the ECU/Valve Assembly? What is the system configuration?

**By having the above information ready when you call, your customer service technician will be better equipped to assist you.**

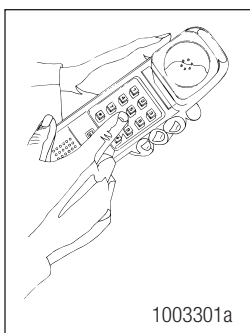

**WABCO Customer Care Center, 855-228-3203**

# Parameter Entry for RSSplus

## 10 Parameter Entry for RSSplus

### 10.1 Vehicle Parameter Records

All RSSplus™ ECUs have default parameters already programmed into the unit. If you are installing a 4S/2M system with the ECU facing FORWARD on an air suspension, there is no need to change any parameters.

If you are installing the RSSplus™ system in a non-default configuration, you will need to access the vehicle parameters. Contact your WABCO representative for assistance with non-default configurations. From the main screen, select System and then Edit Parameters.

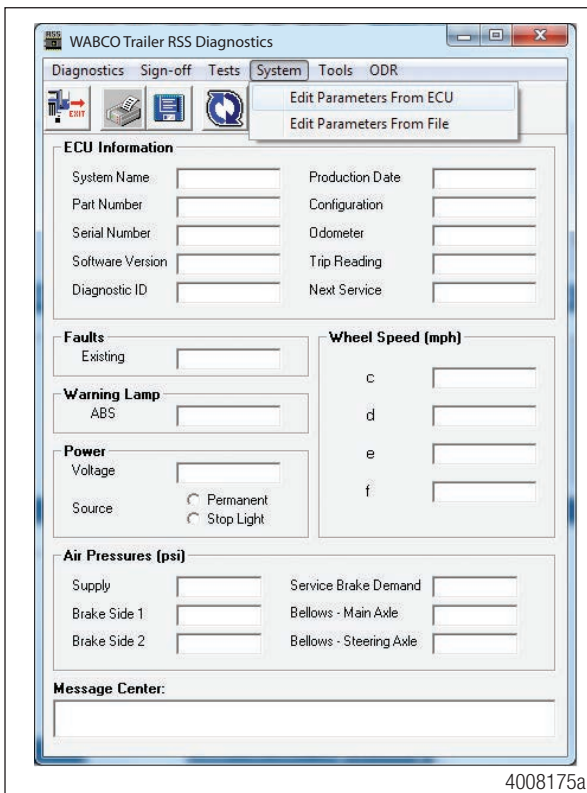



## Parameter Entry for RSSplus

RSS System Parameters allows you to correctly configure the system to match the trailer's specific characteristics. The RSSplus™ ECU comes preprogrammed with default parameters and requires no further programming. You will need to add vehicle data and then press Next to continue.

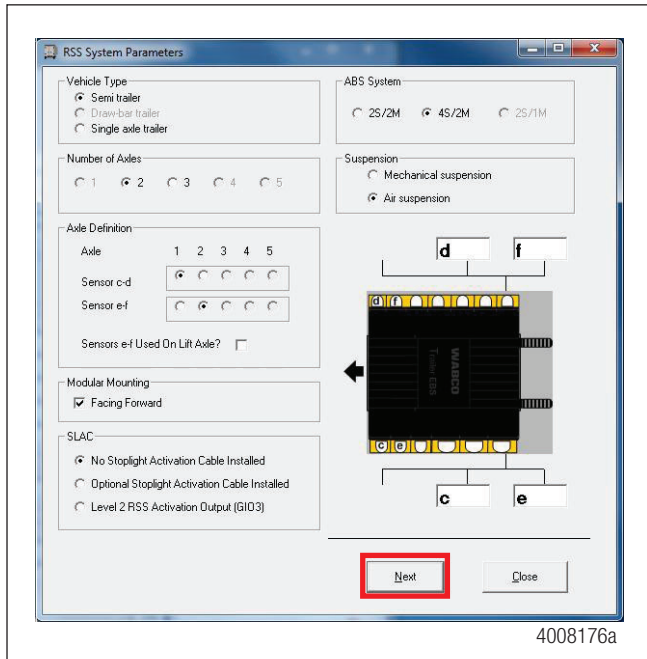

## 10.2 Air Suspension Parameters

Add the following vehicle data into the RSS System Parameters screen.

**Vehicle Type** — Select the appropriate trailer type.

**Number of Axles** — Select the total number of axles on the trailer.

**Axle Definition** — Select the sensed axles by indicating the location of each sensor pair. Lift axles are not sensed and are controlled by generic I/O function. The on-screen illustration will change to reflect the sensor configuration.

**Modulator Mounting** — A modulator facing FORWARD will have the mount bolts pointing TOWARD the rear of the trailer. A forward facing ECU will have this box checked.

**ABS System** — Select the appropriate ABS type being installed.

**Suspension** — Select air suspension. NOTE: Mechanical suspensions are covered in the Mechanical Suspension Parameters section.

**Optional Stoplight Activation Cable** — Select this field ONLY if the stoplight activation cable is installed. This optional cable has additional capabilities over the standard power cable.

# Parameter Entry for RSSplus

Once all the parameters are correctly input, press the NEXT button to advance to the next parameter screen.

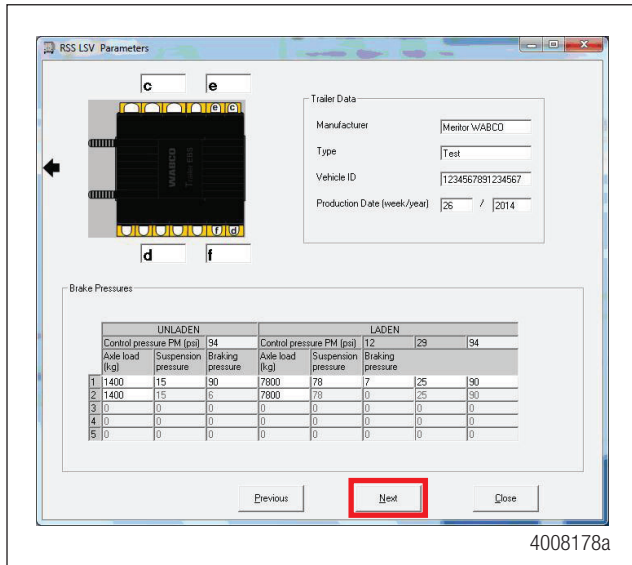

The GIO Selection Screen allows the user to pick which Generic Input/Output files are to be loaded into the ECU. Many of these optional functions are utilized in conjunction with the WABCO PLC Display.

**Tire Inflation System** — The Tire Inflation System Remote Warning.

**Tag Axle (Rear Suspension Dump)** — Releases air from a designated axle to facilitate tight turning.

**Automatic Lift Axle** — Activates the automatic Lift Axle function.

**Door Ajar** — Warns driver if a secure door is not in the locked position.

**Special GIO Functions** — Customized functions specific to the trailer. Click in the appropriate check box to select the function that has been installed on the trailer. Press NEXT to advance to the next parameter screen.

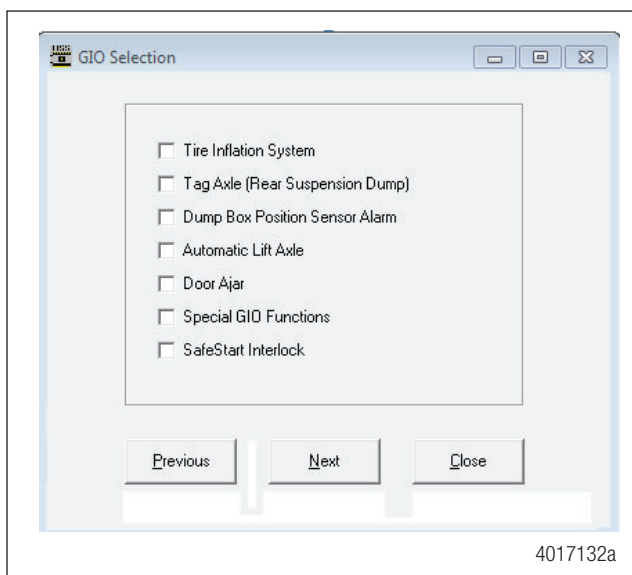

**Trailer Data** — This area contains important data about the trailer.

**Manufacturer** — Enter the manufacturer of the trailer.

**Type** — Enter the trailer type such as tanker, flatbed, van, etc.

# Parameter Entry for RSSplus

**Vehicle I.D.** — Enter the last seven digits of the trailer VIN number or the fleet’s trailer number. Do not leave this field blank as the software creates files using what is entered in this field as file names.

**Production Date** — Enter the trailer’s production date by week number and year.

**Brake Pressures** — This area contains parameters affecting how the trailer brakes perform. These fields are unavailable with mechanical suspensions.

**Additional Characteristic Point** — This box is normally left blank. Checking this box allows brake pressure characteristics to be altered across four bands instead of the standard three.

**Unladen Axle Load (kg)** — Enter the amount of weight each axle will bear when the trailer is empty. The weight in kilograms can be converted from pounds with the formula 2.2 pounds equals 1 kilogram.

**Unladen Suspension Pressure** — The amount of air pressure found in the suspension air bags when the trailer is empty. The suspension pressure is measured in psi (pounds per square inch).

**Unladen Braking Pressure** — The default setting is 90 psi. If brake proportioning is desired, the setting may be less than 90 psi. Do not set this value below 38 psi.

**Laden Axle Load** — Enter the amount of weight each axle will bear when the trailer is fully loaded. The weight in kilograms can be converted from pounds with the formula 2.2 pounds equals 1 kilogram.

**Laden Suspension Pressure** — The amount of air pressure found in the suspension air bags when the trailer is fully loaded. The suspension pressure is measured in psi (pounds per square inch).

**Laden Braking Pressure** — Values in these output fields affect the trailer’s brake performance in the laden condition. There are three columns (left to right) that affect light, medium, and heavy braking. Please contact the WABCO Customer Care Center at 855-228-3203 for assistance if changing these values from the default values.

Once all the values have been correctly determined and entered, press the NEXT button to advance to the last Parameter screen.

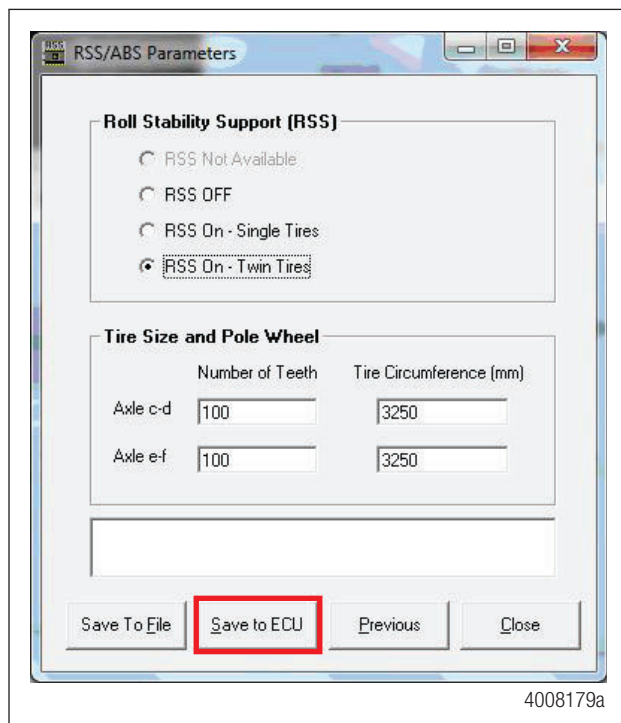

# Parameter Entry for RSSplus

**Roll Stability Support** — If the trailer will have a single wheel on each side of the axle ("Super Singles"), select RSS ON — Single Tires. If the trailer will have dual wheels on each side of the axle, select RSS On — Twin Tires. Only select RSS Off if no roll stability is desired.

**Tire Size and Pole Wheel** — The Number of Teeth field is for the quantity of teeth on the tone ring. Nearly all tone rings have 100 teeth. The Tire Circumference is the dynamic tire radius of the tire in millimeters. The default setting of 3250 will be applicable to most tires, although an exact figure can be obtained from the tire's manufacturer.

Once the parameters have been entered, press the Save to ECU button. The parameters are then saved to the ECU. You are now ready to proceed to the sign-off procedure.

After storing parameters in the ECU, the End-of-Line Start-Up Procedure must be performed. Proceed to the System Sign-Off procedure in Section 9.

## 10.3 Mechanical Suspension Parameters

There are additional parameters for a mechanical suspension trailer that must be configured before releasing the trailer into service.



The distance the springs on a mechanical suspension compress between unladen and laden states is known as "deflection". This value, in millimeters, **MUST** be obtained from the suspension manufacturer prior to programming the ECU. WABCO does not have and cannot provide this essential information. If the value cannot be obtained from the suspension manufacturer, the following procedure can be performed to obtain the value.

### 10.3.1 Determine Spring Deflection Rate

- A. With the trailer unloaded, measure from the top of the axle tube (A) to a fixed point (B) on the underside of the trailer. Note the distance.
- B. With the trailer loaded (maximum load), measure from the same points (A and B) that were used for the trailer unloaded measurement. Note the distance.
- C. Subtract the trailer loaded distance from the trailer unloaded distance. Note the difference. This is the spring deflection rate for this trailer.



Provide the deflection rate in millimeters.

# Parameter Entry for RSSplus

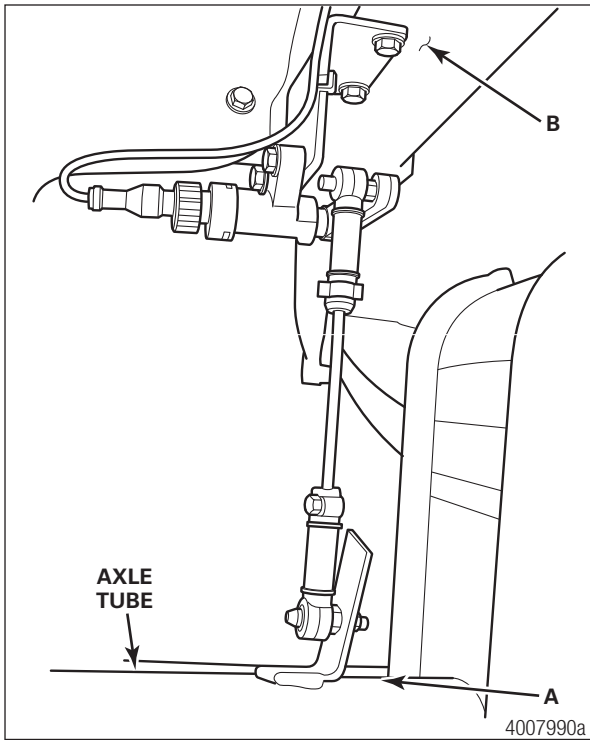

From the main screen, select System and then Edit Parameters.

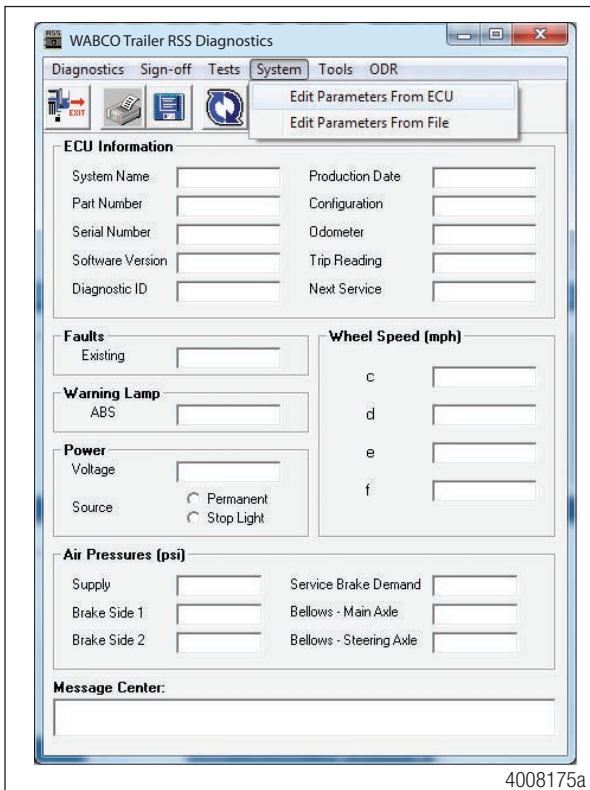

Input the correct values for each data area. Figure 10.8.

# Parameter Entry for RSSplus

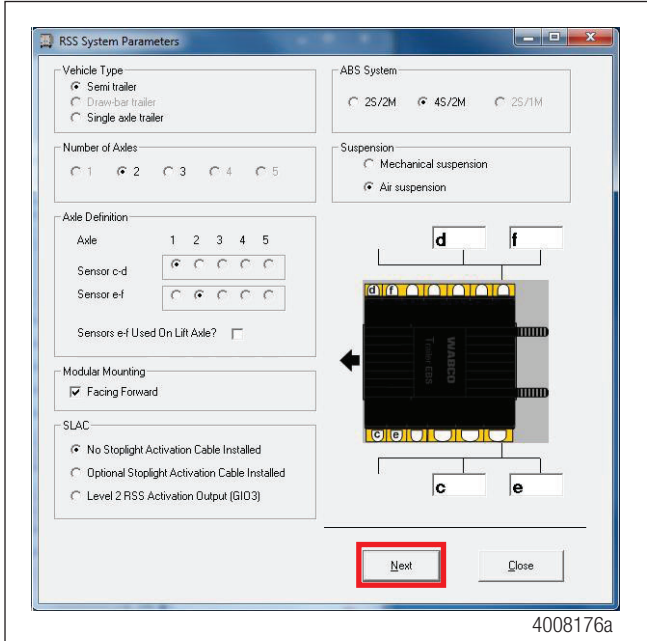

4008176a

**Vehicle Type** — Select the appropriate trailer type.

**Number of Axles** — Select the total number of axles on the trailer.

**Axle Definition** — Select the sensed axles by indicating the location of each sensor pair. Lift axles are not sensed and are controlled by generic I/O function. The on-screen illustration will change to reflect the sensor configuration.

**Modulator Mounting** — A modulator facing FORWARD will have the mount bolts pointing TOWARD the rear of the trailer. A forward facing ECU will have this box checked.

**ABS System** — Select the appropriate ABS type being installed.

**Suspension** — Select Mechanical Suspension.

**Optional Stoplight Activation Cable** — Select this field ONLY if the stoplight activation cable is installed. This optional cable has additional capabilities over the standard power cable.

When all fields are correctly configured, press NEXT to advance to the second parameter screen.

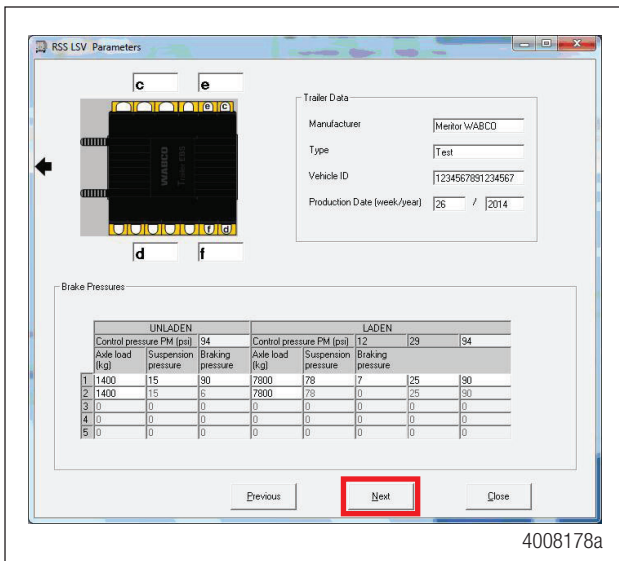

4008178a

## Parameter Entry for RSSplus

The GIO Selection Screen allows the user to pick which Generic Input/Output files are to be loaded into the ECU. Many of these optional functions are utilized in conjunction with the WABCO PLC Display.

**Tire Inflation System** — The Tire Inflation System Remote Warning.

**Tag Axle (Rear Suspension Dump)** — Releases air from a designated axle to facilitate tight turning.

**Lift Axle** — Activates the automatic Lift Axle function.

**Door Ajar** — Warns driver if a secure door is not in the locked position.

**Special GIO Functions** — Customized functions specific to the trailer. Click in the appropriate check box to select the function that has been installed on the trailer. Press NEXT to advance to the next parameter screen.

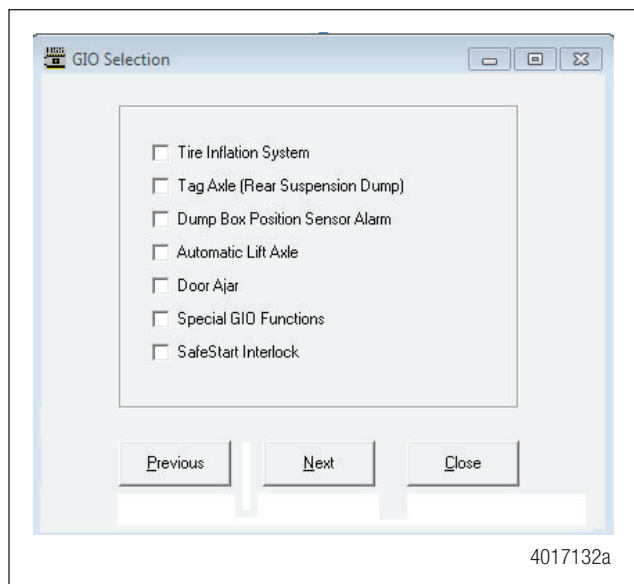

**Trailer Data** — This area contains important data about the trailer.

**Manufacturer** — Enter the manufacturer of the trailer.

**Type** — Enter the trailer type such as tanker, flatbed, van, etc.

**Vehicle I.D.** — Enter the last seven digits of the trailer VIN number or the fleet's trailer number. Do not leave this field blank as the software creates files using what is entered in this field as file names.

**Production Date** — Enter the trailer's production date by week number and year.

**Unladen Axle Load (kg)** — Enter the amount of weight each axle will bear when the trailer is empty. The weight in kilograms can be converted from pounds with the formula 2.2 pounds equals 1 kilogram.

**Unladen Suspension Path** — This value is typically zero for an empty (unladen) trailer.

**Unladen Braking Pressure** — The default setting is 90 psi. If brakeproportioning is desired, the setting may be less than 90 psi. Do not set this value below 38 psi.

**Laden Axle Load** — Enter the amount of weight each axle will bear when the trailer is fully loaded. The weight in kilograms can be converted from pounds with the formula 2.2 pounds equals 1 kilogram.

**Laden Suspension Path** — This value is the amount of spring compression (in millimeters) when the trailer is fully laden. This value is obtained by the trailer builder from the mechanical suspension manufacturer.

## Parameter Entry for RSSplus

**Laden Braking Pressure** — Values in these output fields affect the trailer's brake performance in the laden condition. There are three columns (left to right) that affect light, medium, and heavy braking. Please contact the WABCO Customer Care Center at 855-228-3203 for assistance if changing these values from the default values.

**Distance Sensor Lever Length** — The software defaults to 100 mm. This is the setting when the distance sensor lever is mounted to the farthest integrated nut on the distance sensor. If the lever is mounted to the center integrated nut on the distance sensor arm, the value is 50 mm.

Once all the values have been correctly determined and entered, press the NEXT button to advance to the last Parameter screen.

4008179a

**Roll Stability Support** — If the trailer will have a single wheel on each side of the axle ("Super Singles"), select RSS ON — Single Tires. If the trailer will have dual wheels on each side of the axle, select RSS On — Twin Tires. Only select RSS Off if no roll stability is desired.

**Tire Size and Pole Wheel** — The Number of Teeth field is for the quantity of teeth on the tone ring. Nearly all tone rings have 100 teeth. The Tire Circumference is the dynamic tire radius of the tire in millimeters. The default setting of 3100 will be applicable to most tires, although an exact figure can be obtained from the tire's manufacturer.

Once the parameters have been entered, press the Save to ECU button. The parameters are then saved to the ECU. You are now ready to proceed to the sign-off procedure.



## 11 Troubleshooting

Observe the following hazard alert messages when performing troubleshooting procedures.

### **WARNING**

To prevent serious eye injury, always wear safe eye protection when you perform vehicle maintenance or service.

### **WARNING**

Remove all pressure from the air system before you disconnect any component. Pressurized air can cause serious personal injury.

### **WARNING**

Park the vehicle on a level surface. Block the wheels to prevent the vehicle from moving. Support the vehicle with safety stands. Do not work under a vehicle supported only by jacks. Jacks can slip and fall over. Serious personal injury and damage to components can result.

### **WARNING**

Ensure the trailer has correct electrical grounding; refer to SAE Specification J1908.

### **WARNING**

When you work on an electrical system, the possibility of electrical shock exists, and sparks can ignite flammable substances. You must always disconnect the battery ground cable before you work on an electrical system to prevent serious personal injury and damage to components.

### 11.1 Lift Axle Troubleshooting

The first step taken when troubleshooting the Lift Axle system is to ensure that the system is pneumatically plumbed and electrically connected correctly. Refer to Figures 11.9, 11.10 and 11.11 in this section for the correct schematic, depending upon the configuration.

For additional information, refer to TP08103, Lift Axle Installation Manual, available at [wabco-auto.com](http://wabco-auto.com).

When testing the Lift Axle system, ensure the trailer is supplied with a minimum of 100 psi air pressure to the supply air and 12 volts DC power rated at a minimum of 10 amps to the trailer's constant power circuit.

Use of a volt-ohm meter may be required. A lift axle test rig may be built by the maintenance shop to facilitate the testing of the lift axle system. See Figure 11.12.

The ability to raise the trailer's fixed axles in order to conduct an end of line test may be required.

This troubleshooting section is based on the use of TOOLBOX™ Software version 12.2 or higher. If you have an earlier version of software, visit [wabco-auto.com](http://wabco-auto.com) or contact your Snap-On dealer.

# Troubleshooting

Condition Experience	Action to Take	Troubleshooting Details
Lift Axle Function Unavailable in TOOLBOX™ Software	Inspect RSS2 ECU electrical connections.	Ensure that all cables are correctly installed.
	Verify the TOOLBOX™ Software version.	Ensure TOOLBOX™ Software 12.2 or later is installed.
Lift Axle Will Not Raise or Lower	Recycle trailer power.	The ECU valve should audibly click during its power-up self-test. If the ECU fails to click, ensure that the sensor extension cables are securely attached to the ECU and ensure that 12 volts is present at pin 1 on the ECU power connector. Refer to Figure 11.1.
	Retrieve diagnostic information via TOOLBOX™ Software version 12.2 or higher.	When the trailer power is cycled, the trailer-mounted ABS warning light will illuminate and extinguish as a light test. If warning light remains on, begin diagnostics with TOOLBOX™ Software. Repair and clear all faults found.
	Check the Notebook feature in TOOLBOX™ Software to determine if lift axle function has been enabled.	Service information will display raise and lower pressures if the lift axle function is active when using TOOLBOX™ Software version 12 or greater.
	Verify the lift axle function is activated in TOOLBOX™ Software.	From the main TOOLBOX screen, select the Modify pull-down. Select Lift Axle Raise/Lower Pressures and active settings will be displayed. Input values if needed and save to ECU.
	Inspect lift axle control valve (LACV) cable 449 518 030 0.	Ensure the LACV cable 449 518 030 0 is securely fastened to the LACV and to the "D1" lead of the multiple I/O cable 449 866 010 0.
	Inspect multiple I/O cable 449 442 010 0.	Ensure the multiple I/O cable 449 442 010 0 is securely fastened to the ECU and that the "D1" lead is connected to the LACV cable 449 518 030 0.
	Check lift axle control valve cable integrity.	Using a volt/ohm meter, check for shorted or open circuits on LACV cable 449 518 030 0. Refer to Figure 11.2.
	Check multiple I/O cable integrity.	Using a volt/ohm meter, check for shorted or open circuits on lead "D1" of the multiple I/O cable 449 866 010 0. Refer to Figure 11.3.
	Inspect the lift axle control valve 463 084 050 0.	Ensure the LACV cable is securely fastened to the valve.
	Check the coil of the lift axle control valve.	Using an ohm meter, check the resistance between pins 1 and 4 and pins 1 and 2. The resistance should be 19 ohms (+/- 2 ohms at room temperature). Resistance between pins 2 and 4 should be less than 1 ohm. Refer to Figure 11.4.

# Troubleshooting

Condition Experience	Action to Take	Troubleshooting Details
	Test the pressure switch 431 700 002 0.	Refer to Figure 11.5 for the connector diagram of Pressure Switch 431 700 002 0. Use regulated shop air and an ohm meter to check the functionality of the switch. With greater than 70 psi (but less than 120 psi) applied to the switch, pins 1 and 2 resistance reading should show infinity. With less than 70 psi applied to the switch, pins 1 and 2 resistance reading should show less than 1 ohm.
	Test the pressure sensor 441 044 106 0.	Refer to Figure 11.12 for the construction of a Lift Axle Test Rig. Attach regulated shop air to the pneumatic connector of pressure switch 441 044 106 0. Increase pressure so that it exceeds the parameterized lower axle threshold and the axle should deploy. Decrease pressure so that it drops below the parameterized threshold to raise the axle and the axle should rise. Replace the Pressure Sensor if axle fails to rise or lower.
	Check "Y" cable integrity (if applicable).	Using a volt/ohm meter, check for a shorted or open circuit on the lift axle "Y" cable 894 590 075 0. Refer to Figure 11.8.
Lift Axle with Automatic Override Will Not Lower When Trailer is Parked; Trailer Has Power and Air Applied	Using TOOLBOX™ Software, ensure there are no active faults.	Repair and clear all active faults. Cycle the ECU power.
	Inspect pressure switch 431 700 001 0 installation.	Ensure pressure switch is plumbed into the delivery line to the spring brake. Refer to Figures 11.9, 11.10 and 11.11.
	Inspect the connection of pressure switch 431 700 001 0.	Ensure the pressure switch is correctly connected to the "A1" lead of the multiple I/O cable 449 866 010 0.
	Test the pressure switch 431 700 001 0.	Refer to Figure 11.5 for the connector diagram of pressure switch 431 700 001 0. Use regulated shop air and an ohm meter to check the functionality of the switch. With greater than 70 psi applied to the switch, pins 1 and 2 resistance reading should show infinity. With less than 70 psi applied to the switch, pins 1 and 2 resistance reading should show less than 1 ohm.
	Check "Y" cable integrity (if applicable).	Using a volt/ohm meter, check for shorted or open circuits on ABS "Y" cable 894 590 075 0. Refer to Figure 11.8.
	Check multiple I/O cable integrity.	Using a volt/ohm meter, check for a shorted or open circuit on the "A1" lead of multiple I/O cable 449 866 010 0. Refer to Figure 11.3.

# Troubleshooting

Condition Experience	Action to Take	Troubleshooting Details
Lift Axle Will Not Lower When Trailer Is Unpowered	Inspect the pneumatic connections at the lift axle control valve 463 084 050 0.	Refer to Figures 11.9, 11.10 and 11.11 for the plumbing schematics, depending on system configuration.
Lift Axle Raises When Trailer is Moving	ECU was programmed with an out-of-date version of TOOLBOX™ Software.	Reprogram ECU with TOOLBOX™ Software version 12.2 or higher.
Lift Axle Lowers Only When Tractor Brakes are Applied	Verify power to the ECU.	Ensure the trailer has blue center pin power at the J560 connector at the front of the trailer. Inspect the towing vehicle's power output to the J560. Ensure the J560 is wired correctly to the trailer OEM's specifications.
	Check power cable throughput.	Ensure 12 volts DC power is present at pin 1 on power cable 449 351 010 0. Refer to Figure 11.1.
	Check power cable throughput.	Ensure 12 volts DC power is present at the power cable 449 351 010 0 from the ABS breakout of the trailer power cable. Refer to Figure 11.1.
	Inspect trailer power/light cable.	Using a volt/ohm meter, check for shorted or open circuits on the trailer power/light cable from the J560 connector at the trailer nose to the ABS breakout pigtail. Continuity should be found between pin 7 on the J560 and the pin mating with pin B on the ABS power cable. Refer to Figures 11.1 and 11.13.
Manual Override Switch Does Not Function	Inspect the manual override switch and 12v analog input cable 449 428 030 0.	Ensure the lift axle control valve is functional by disconnecting the LACV cable from the LACV. The axle should lower.
	Verify toggle switch operation.	Ensure the toggle switch is functional using an ohm meter. Switch output should show infinity ohms when the switch is in the OFF position and less than 1 ohm when the switch is in the ON position.
	Check multiple I/O cable integrity.	Using a volt/ohm meter, check for a shorted or open circuit on the "A1" lead of multiple I/O cable 449 866 010 0. Refer to Figure 11.3.

# Troubleshooting

Condition Experience	Action to Take	Troubleshooting Details
Lift Axle Lowers When Powered Trailer Stops Moving	Verify override switch functionality.	Ensure the manual override toggle switch is not intermittently functional by checking with an ohm meter. Switch output should show infinity ohms when the switch is in the OFF position and less than 1 ohm when the switch is in the ON position. Induce vibration to the switch and switch wiring when checking switch activation.
	Inspect toggle switch installation.	Ensure wires connected to the switch are secure and not damaged.
	Inspect pneumatic component installation.	Ensure pressure switch 431 700 001 0 is plumbed correctly. Refer to Figures 11.9, 11.10 and 11.11 for the plumbing schematics, depending on system configuration.
	Check multiple I/O cable integrity.	Using a volt/ohm meter, check for a shorted or open circuit on the "A1" lead of the multiple I/O cable 449 866 010 0. Refer to Figure 11.3.
	Check analog input cable integrity.	Using a volt/ohm meter, check for a shorted or open circuit on the analog input cable 449 711 060 0. Refer to Figure 11.6.
	Check "Y" cable integrity (if applicable).	Using a volt/ohm meter, check for a shorted or open circuit on the lift axle "Y" cable 894 590 075 0. Refer to Figure 11.8.
Lift Axle Lowers and/or Raises at Values Inconsistent With Values in the ECU Parameter Settings	Inspect lift axle control valve 463 084 050 0 installation.	Ensure that there are no air leaks in the air circuit where lift Axle control valve 463 084 050 0 is attached.
	Inspect system wiring.	Ensure the system is wired correctly. Refer to Figures 11.9, 11.10 and 11.11 depending on the system configuration.
	Ensure correct ECU configuration.	Reprogram ECU with TOOLBOX™ Software version 12.2 or greater.
Optional Lift Axle Indicator Lamp Does Not Illuminate	Inspect LED lamp assembly.	Ensure the load-resistored LED or incandescent lamp is functional.
	Inspect LED lamp assembly.	Ensure load-resistored LED or incandescent lamp is wired correctly. Ensure the brown wire is connected to ground and the black wire is connected to power.
	Verify ECU voltage output.	A reading of 3 volts DC should be read across the two pins on "D1" of the light output cable 449 711 030 0 when the light is not illuminated (lift axle down). A reading of 12v DC should be read across the two pins on "D1" of the light output cable 449 711 030 0 when the light is illuminated (lift axle up).
	Check light output cable integrity.	Using a volt/ohm meter, check for a shorted or open circuit on cable 449 711 030 0. Refer to Figure 11.7.

# Troubleshooting

Condition Experience	Action to Take	Troubleshooting Details
Optional Lift Axle LED Indicator Lamp Stays on Faintly	Inspect indicator lamp and cable.	If damaged, replace the LED lamp with a load-resistored LED or incandescent lamp.
	Inspect indicator light wiring.	Ensure the load-resistored LED lamp is wired correctly. Make sure the brown wire is connected to ground and the black wire hooked to power.
	Inspect indicator light.	When using an LED lamp, ensure the LED assembly has a 1k ohm load resistor. When using an incandescent light, ensure that a 12v light is being used.
	Check light output cable integrity.	Using a volt/ohm meter, check for a shorted or open circuit on light output cable 449 711 030 0. Refer to Figure 11.7.
Pressure Switch Test	Check pressure switch 431 700 001 0 functionality.	Refer to Figure 11.5 for the connector diagram of pressure switch 431 700 001 0. Use regulated shop air and an ohm meter to check the functionality of the switch. With greater than 70 psi (and less than 100 psi) applied to the switch, pins 1 and 2 resistance reading should show infinity. With less than 70 psi applied to the switch, pins 1 and 2 resistance reading should show less than 1 ohm.

Fig. 11.1

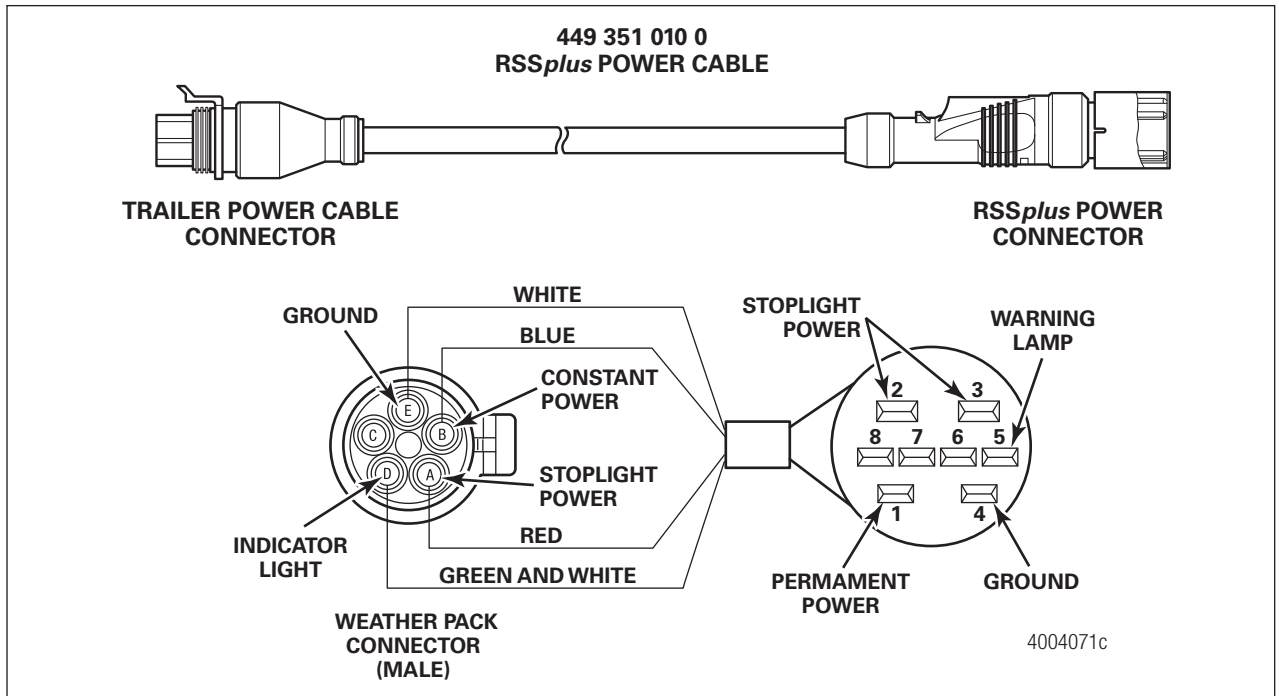

Fig. 11.2

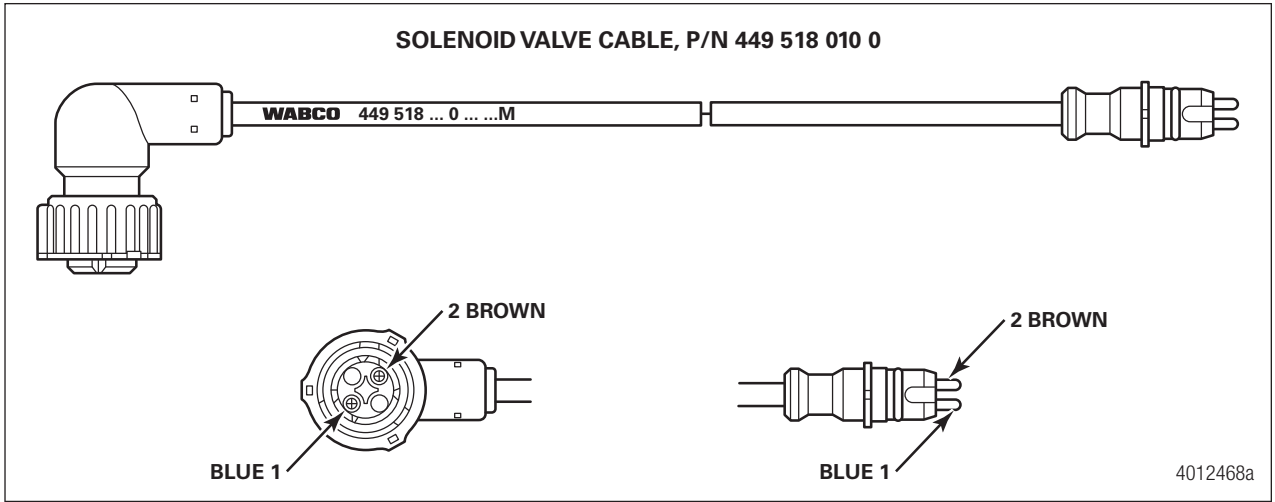

Fig. 11.3

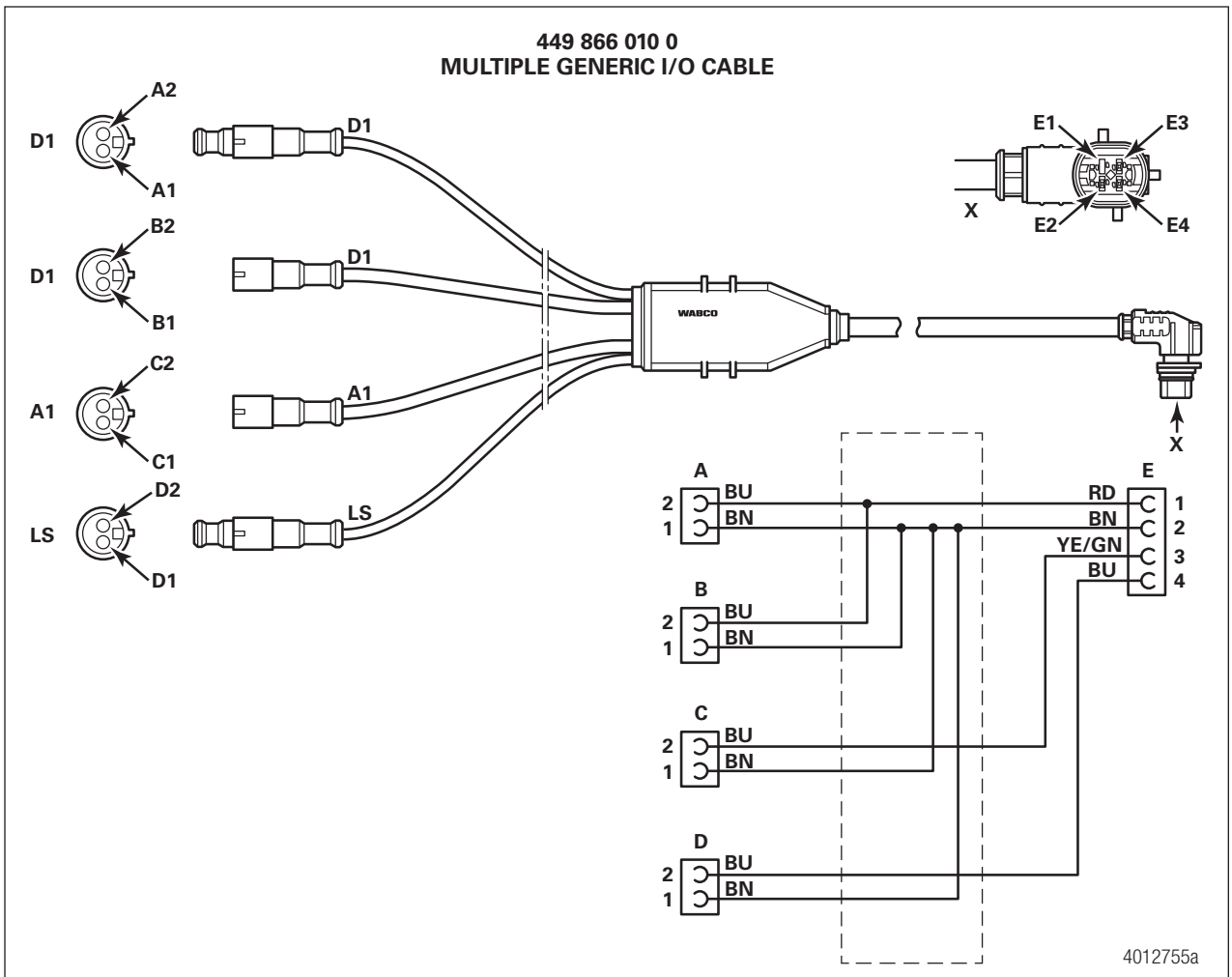

Fig. 11.4

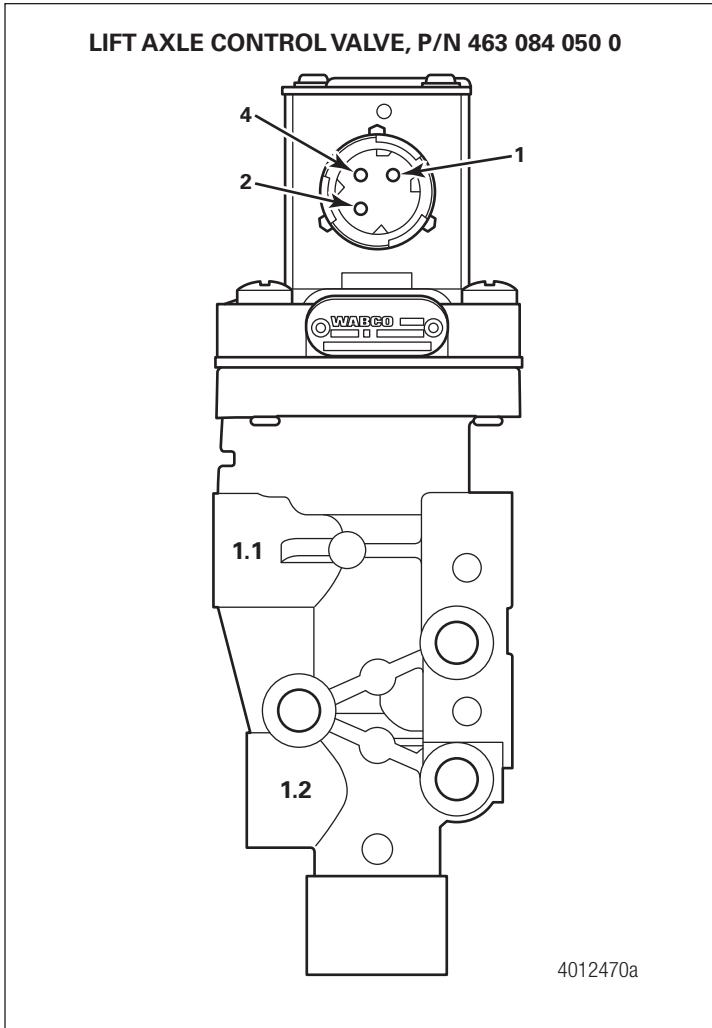



Fig. 11.5

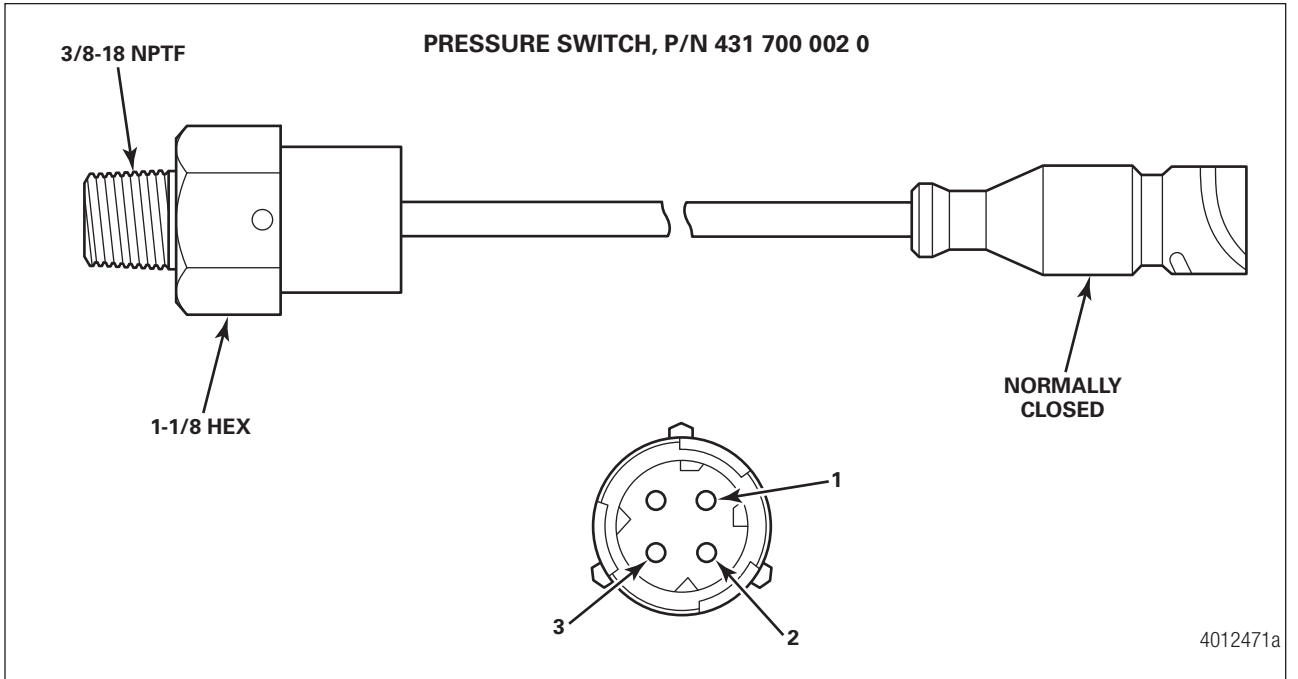

Fig. 11.6

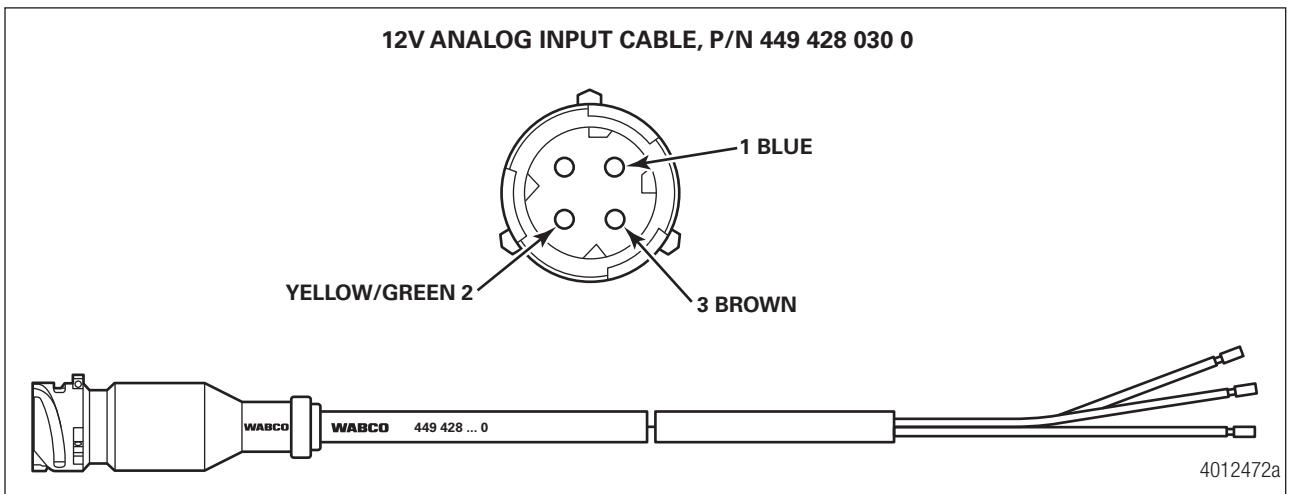

Fig. 11.7

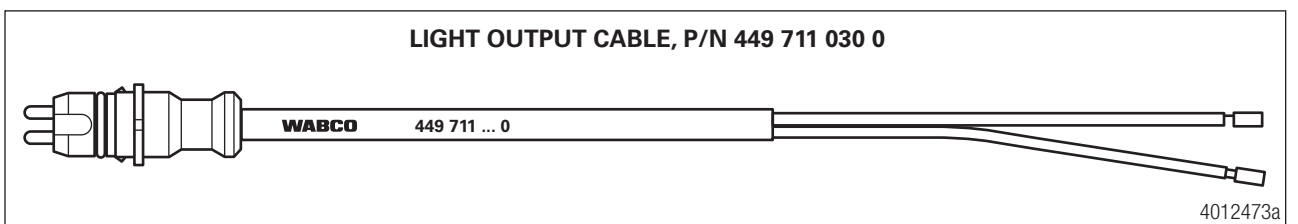

Fig. 11.8

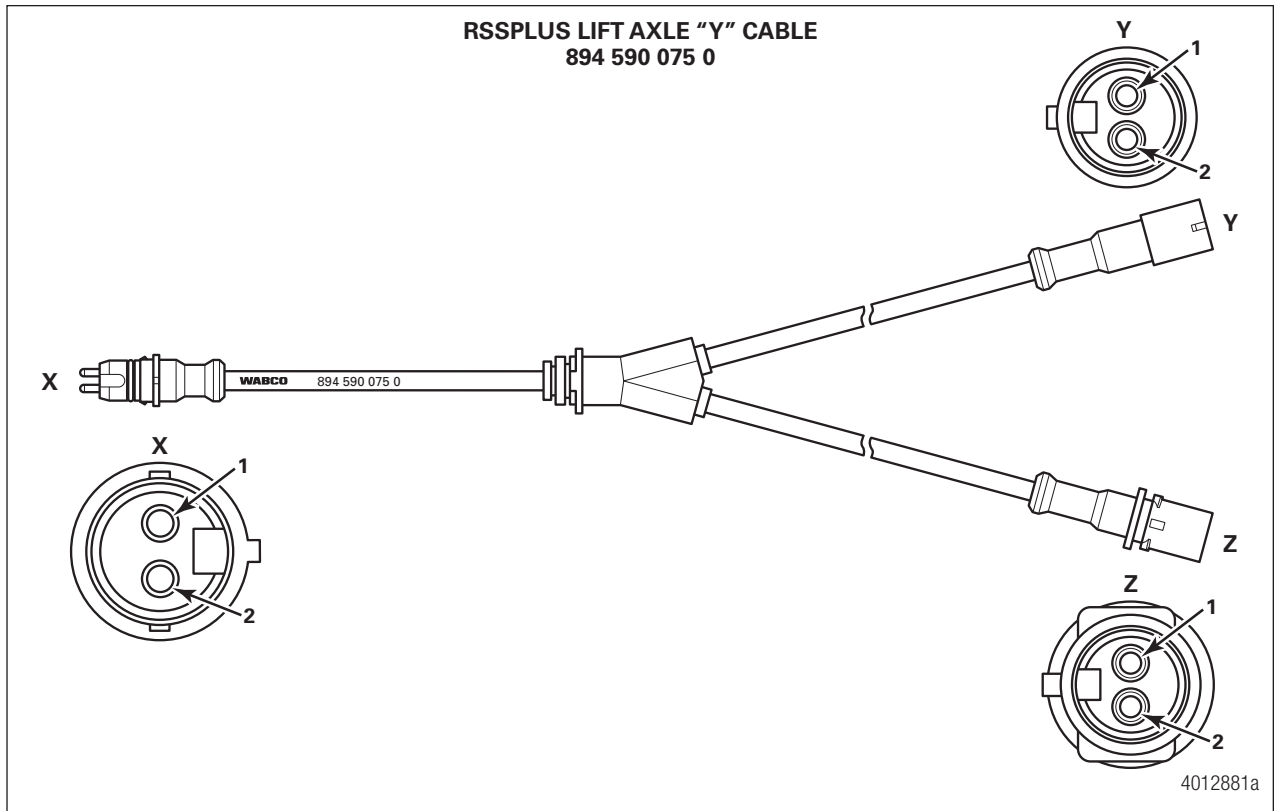

Fig. 11.9

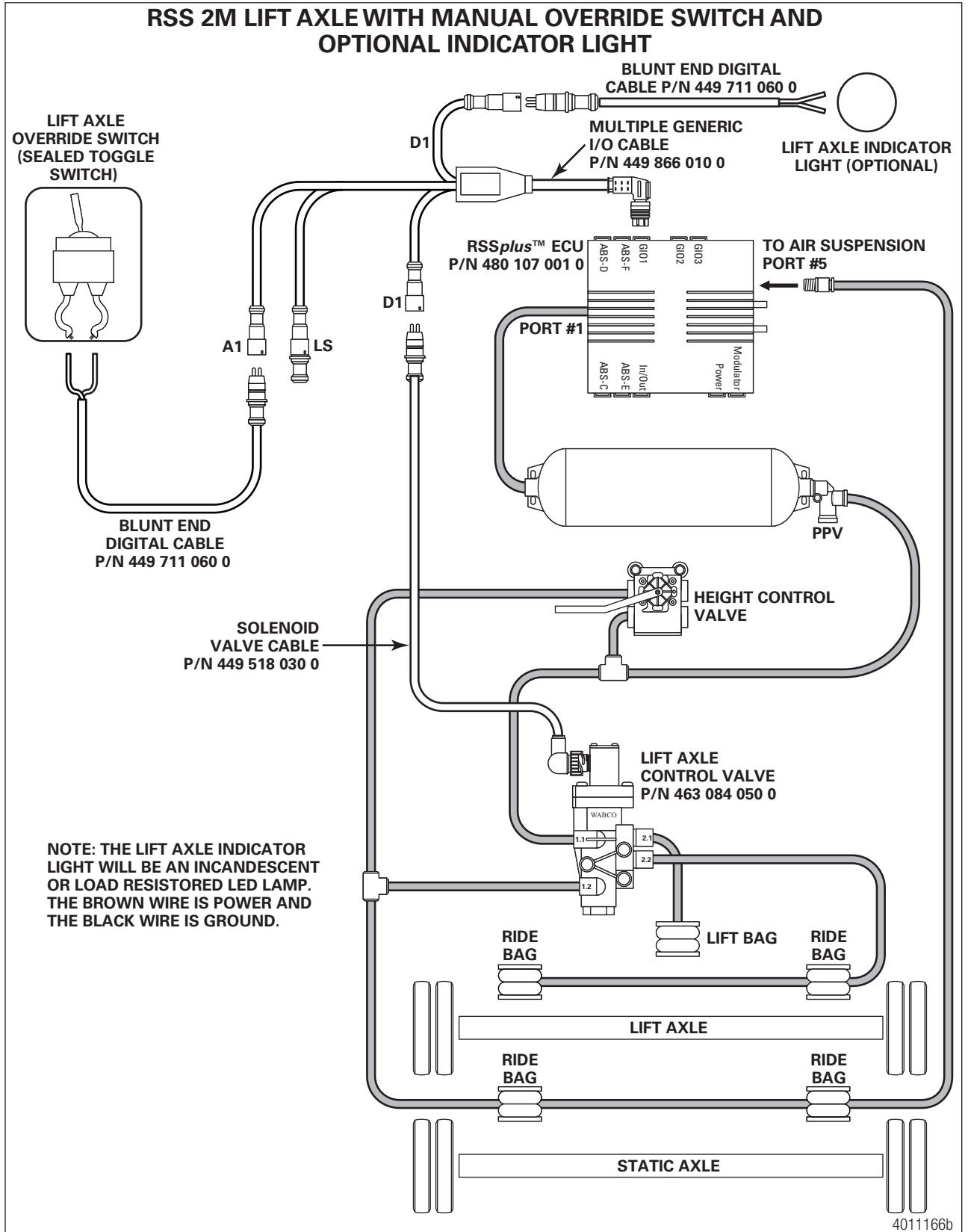

Fig. 11.10

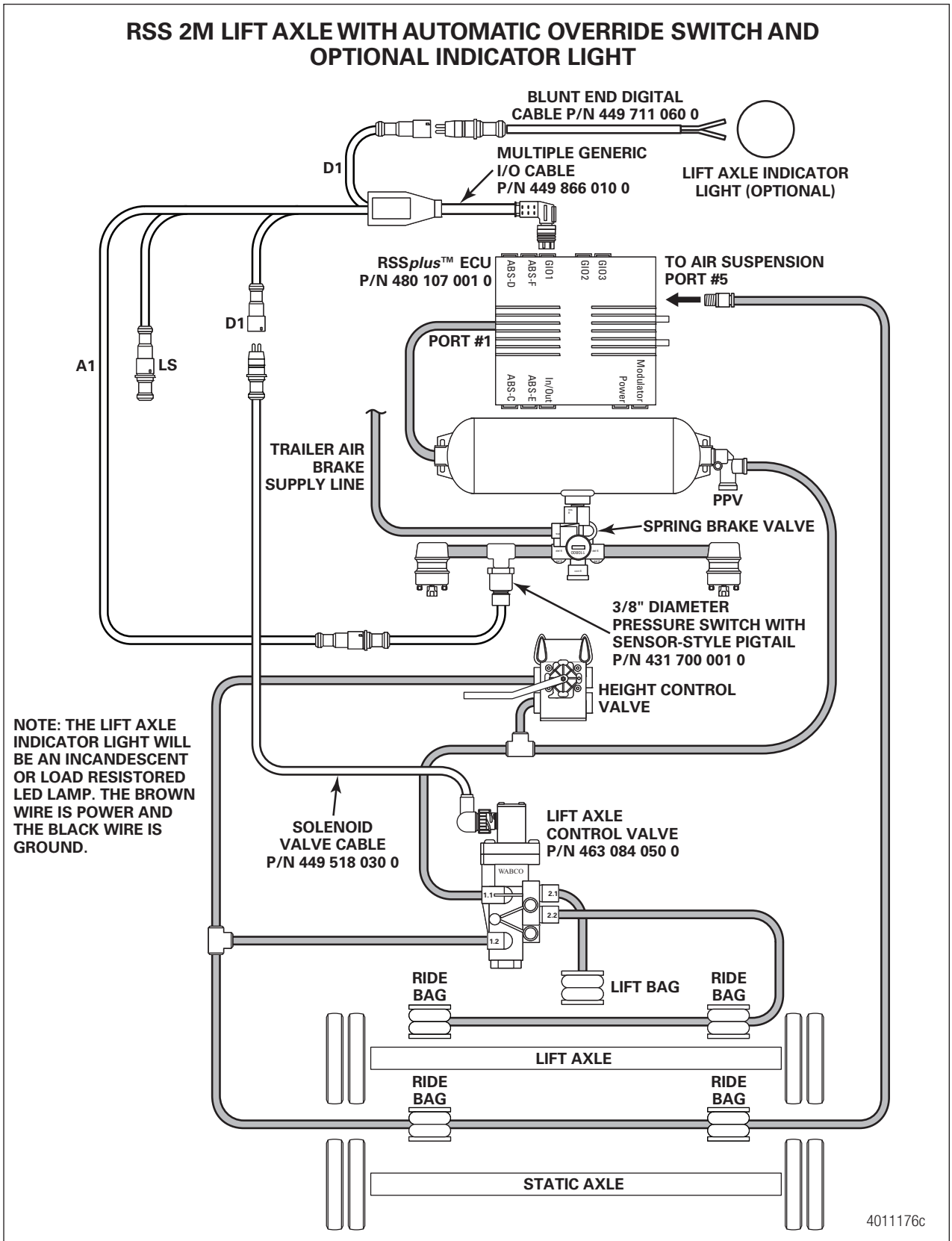
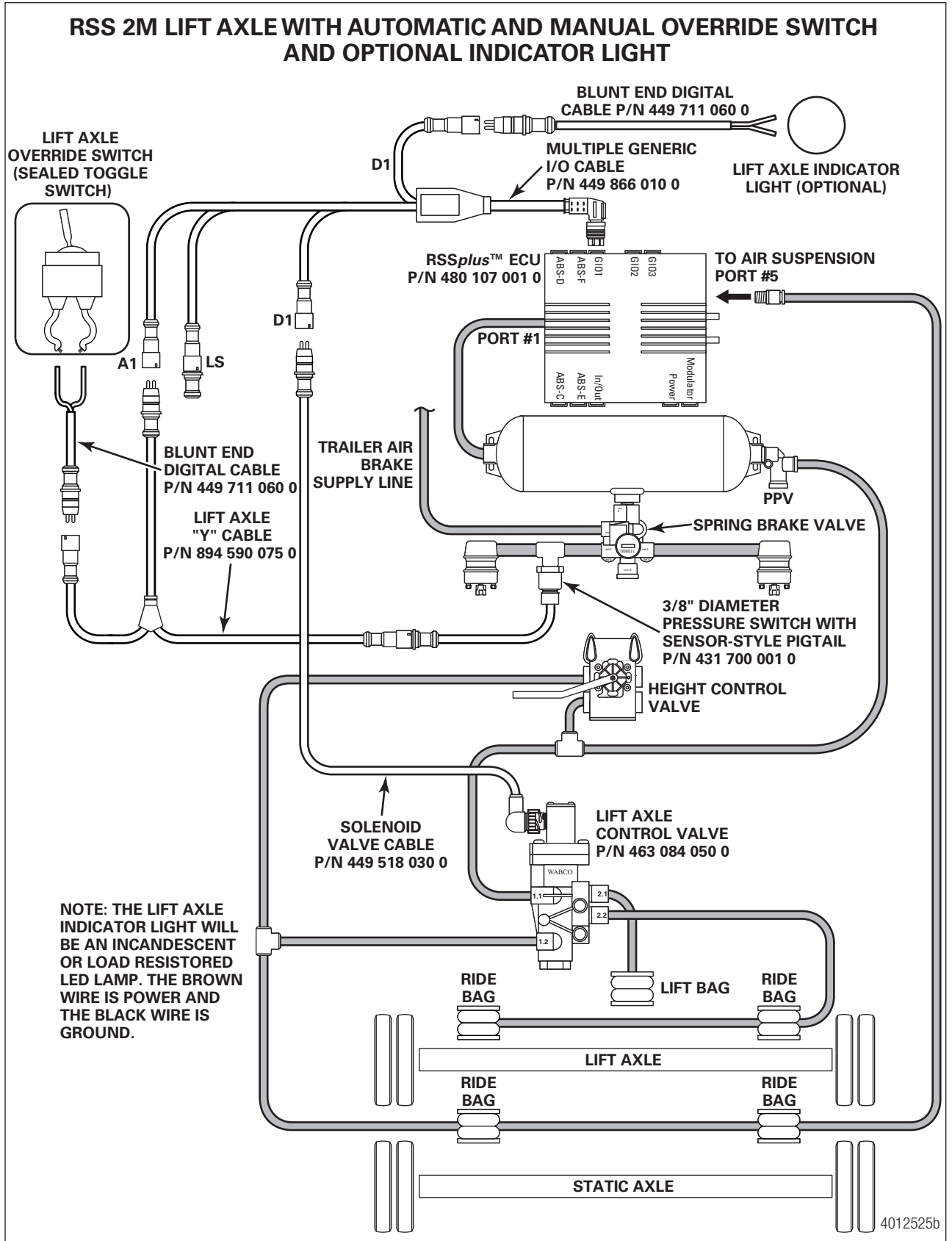

Fig. 11.11



4012525b

Fig. 11.12

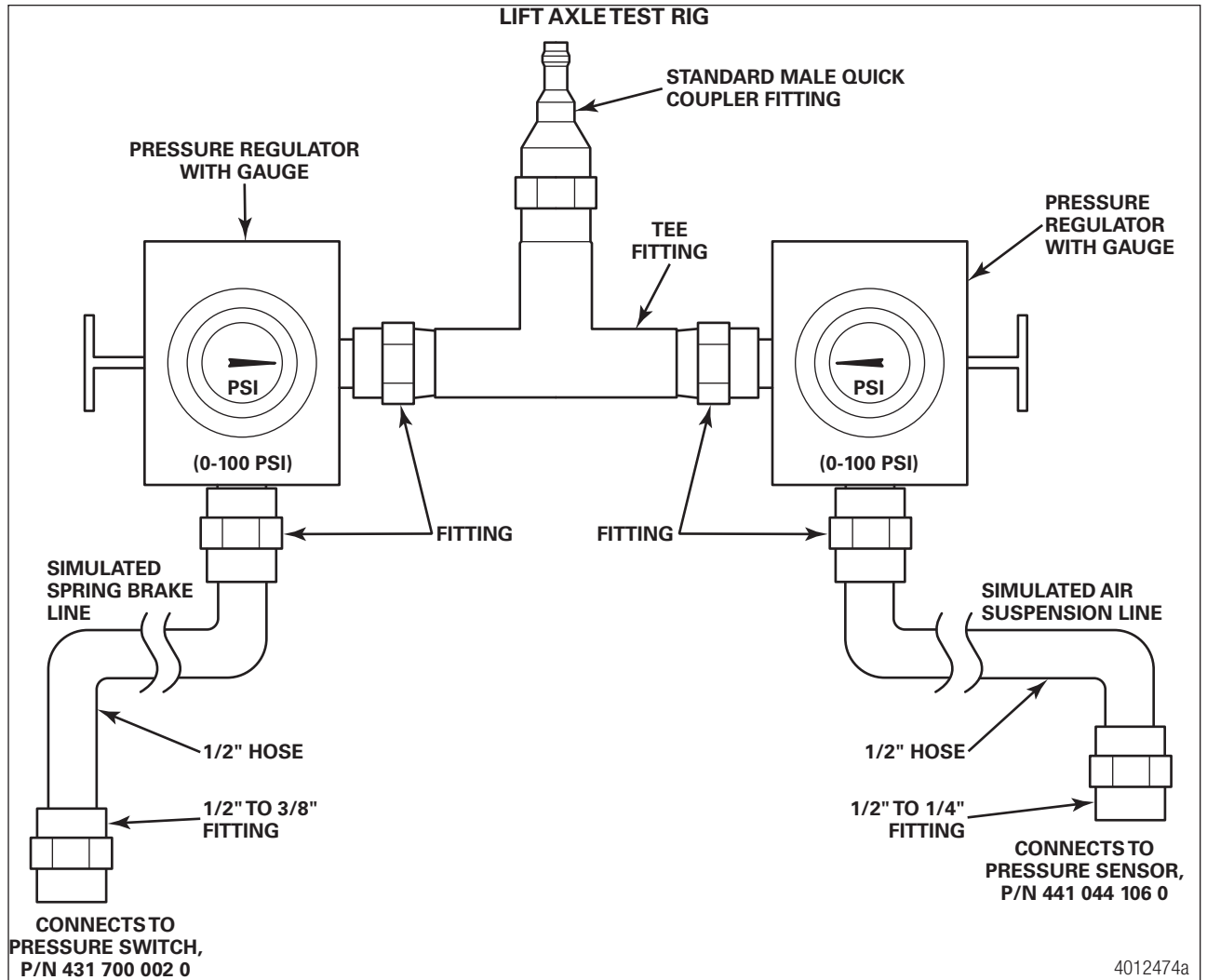
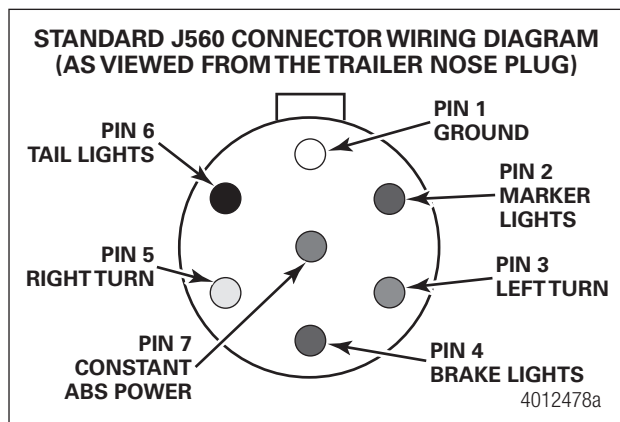

Fig. 11.13



## 11.1.1 Activating the Lift Axle Option with TOOLBOX™ Software

Once the hardware has been installed, the Lift Axle option must be activated using WABCO TOOLBOX™ software version 12.2 or later. When installing the Lift Axle option on new or replacement ECUs, the activation process is part of your normal programming procedure. Refer to the procedures in this manual or Installation Guide TP0887, Trailer ABS with Roll Stability Support (RSS*plus*™) for Trailers with Air or Mechanical Suspensions, for step-by-step instructions on programming and conducting the End-of-Line test.

1. Activate the Roll Stability portion of TOOLBOX™ Software. From the top menu bar, go to the System pull-down menu and select Edit Parameters from ECU. Figure 11.14.

Fig. 11.14

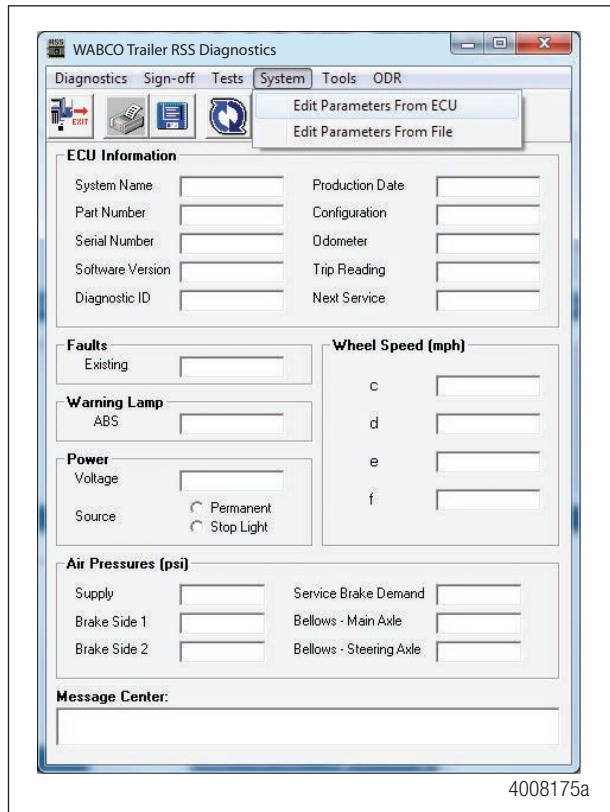

2. From the first parameter screen labeled RSS System Parameters, ensure that the settings are correct. Within the Axle Definition area, if the lift axle is a sensed axle, be sure that sensors "e" and "f" are on the lift axle and that the "Sensors e-f Used On Lift Axle" box is checked. If the lift axle is not sensed, indicate "e" and "f" on the appropriate axle and do not check the box. Once all the settings are correct, press the Next button. Figure 11.15.

Fig. 11.15

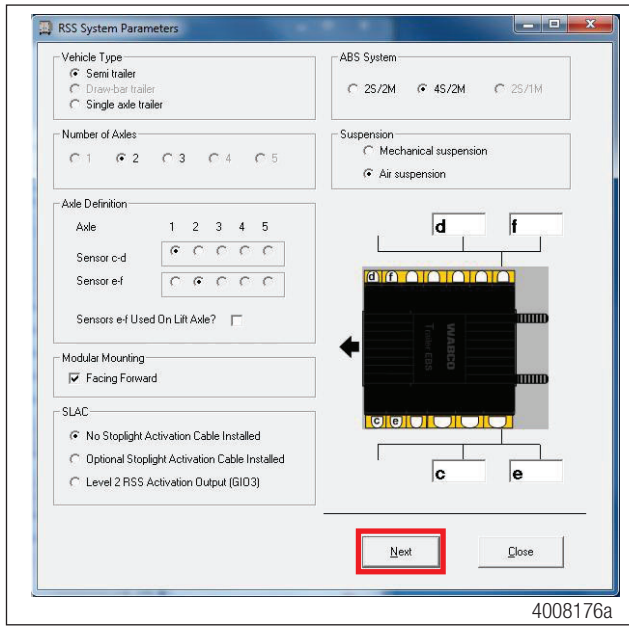

3. The GIO Selection screen appears. Click the Lift Axle check box. Ensure that a check appears in the box. Then press the Next button at the bottom of the screen. Figure 11.16.

Fig. 11.16

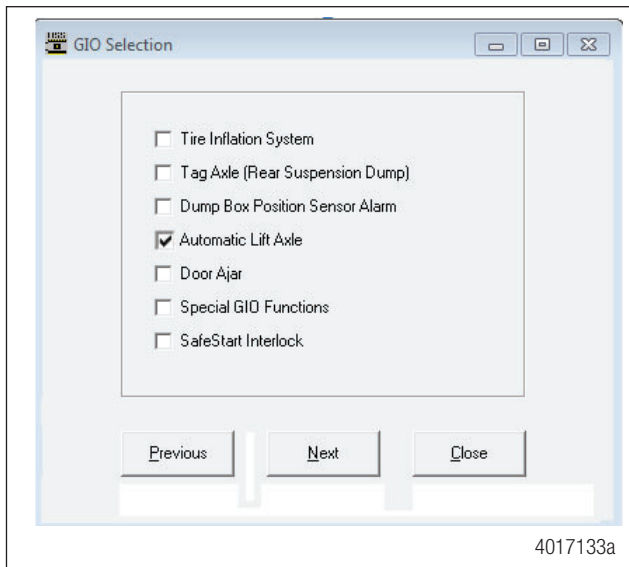



- The Lift Axle Lowering/Lifting Pressures screen appears. Enter in the correct lift and lowering values for the Lift Axle, based upon the trailer's specific requirements (these values may only be obtained directly from the suspension manufacturer). Note: Inputting anything other than the trailer specific values can result in improper functioning of the lift axle. Type the Lowering and Lifting Pressures in the fields provided. The values must fall within the following restrictions:
  - Valid range: 5-100 psi
  - Lowering Pressure must be greater than Lifting Pressure
  - Lowering and Lifting Pressures must differ by at least 15 psi

Press the OK button at the bottom of the window. Figure 11.17. You will be returned to the GIO Selection screen where you will press the Next button.

Fig. 11.17

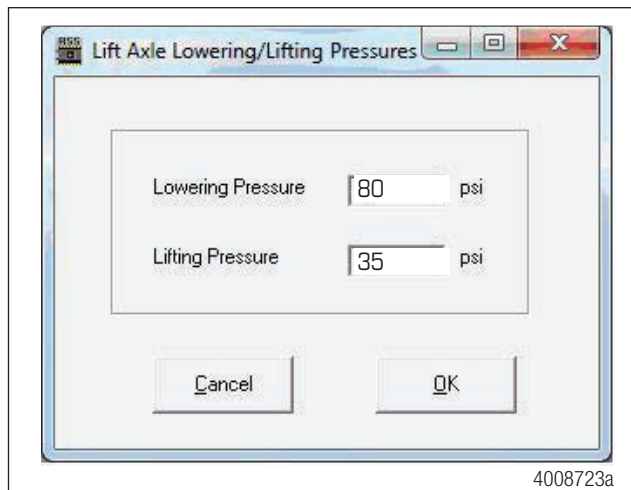

- From the screen labeled RSS LSV Parameters, press the Next button at the bottom of the screen. There is no need to change the values if you are using the default settings. Figure 11.18.

Fig. 11.18

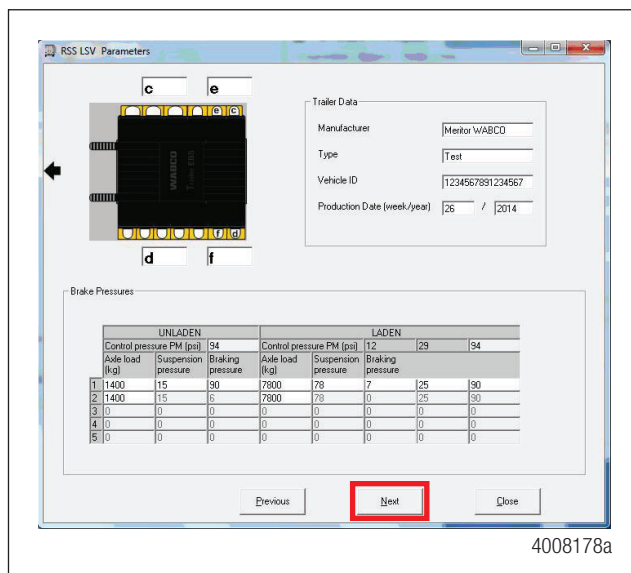

6. From the screen labeled RSS/ABS Parameters, press the Save to ECU button at the bottom of the screen. NOTE: Ensure that one of the RSS On options is selected. Figure 11.19.

Fig. 11.19

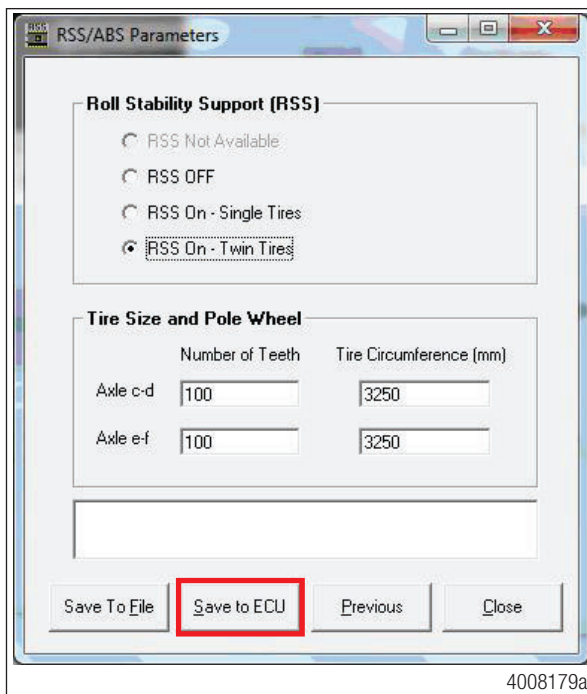

7. Once a message appears confirming a successful save, you may exit the TOOLBOX™ Software. Be sure to cycle the power on the trailer in order to reset the ECU. The End-Of-Line test that is required on new ECU's is not necessary for a previously programmed ECU.

## 11.1.2 Lift Axle Test

The Lift Axle Test must be performed after the RSS system has been properly programmed and, if needed, the End of Line Test has been successfully performed.

The trailer must have constant power applied, have air supplied to the supply/emergency (red) line, and air supplied to the ride bags.

## 11.1.3 Lift Axle Test — Manual Override

The trailer must have power applied and have air supplied to both the supply/emergency (red) line and the air suspension circuit. A second regulated air supply is required for this test. A test rig illustrated in Figure 11.12 may be used.

1. Activate the manual override switch to confirm that the lift axle lowers in an unladen state. The optional lift axle indicator light should extinguish. Once confirmed, return the switch to its original position, the lift axle should raise, and the optional lift axle indicator light should illuminate.
2. Exhaust the trailer's air system.
3. Remove the air line from port #5 on the ECU valve assembly and plug the air line that was removed.
4. Connect regulated air to port 5 on the ECU valve assembly. It should allow air pressure between 0 and 95 psi to be applied to port 5.
5. Refill the trailer air system through the supply/emergency (red) line.

6. Increase the regulated air pressure going to port 5 so that it equals or exceeds the value set in the TOOLBOX™ Software to lower the axle. The lift axle should lower and the optional lift axle indicator light should extinguish.
7. Reduce the regulated air pressure going to port 5 so that it equals or drops below the value set in the TOOLBOX™ Software to raise the lift axle. The lift axle should raise and the optional lift axle indicator light should illuminate.
8. Remove power to the trailer. The lift axle should lower.
9. Exhaust the trailer air system. Remove the regulated air from the ECU valve assembly's port 5. Unplug the suspension air line and reconnect to port 5.

This completes the manual override lift axle test. If results differ from what is stated above, inspect the installation and program parameters. Make corrections as needed.

## 11.1.4 Lift Axle Test – Automatic Override

The trailer must have power applied and air to the normal air suspension available.

The trailer must have constant power applied and have air available for the supply/emergency (red) line. A second regulated air supply is required for this test. A test rig illustrated in Figure 11.12 may be used.

1. Exhaust the trailer's air system.
2. Remove the air line from port #5 on the ECU valve assembly and plug the air line that was removed.
3. Connect regulated air to port 5 on the ECU valve assembly. It should allow air pressure between 0 and 95 psi to be applied to port 5.
4. Refill the trailer air system through the supply/emergency (red) line.
5. Increase the regulated air pressure going to port 5 so that it equals or exceeds the value set in the TOOLBOX™ Software to lower the axle. The lift axle should lower and the optional lift axle indicator light should extinguish.
6. Reduce the regulated air pressure going to port 5 so that it equals or drops below the value set in the TOOLBOX™ Software to raise the lift axle. The lift axle should raise and the optional lift axle indicator light should illuminate.
7. Remove power to the trailer. The lift axle should lower and the optional lift axle indicator light should extinguish.
8. Exhaust the trailer air system. Remove the regulated air from the ECU valve assembly's port 5. Unplug the suspension air line and reconnect to port 5.

Testing the configuration that has the delivery line pressure switch in place of the manual toggle switch requires a tractor. Correct operation should be tested after the trailer End of Line test has been completed.

1. Attach the unladen trailer to a tractor and ensure both air and power are hooked up.
2. Release the trailer spring brakes using the red trailer brake valve on the tractor dash. The lift axle should move to the raised position once the spring brake has released and the optional indicator light should illuminate.
3. Apply the spring brakes (exhausting air) using the red trailer brake valve on the tractor dash. The lift axle should lower and the optional lift axle indicator light should extinguish.

This completes the automatic override lift axle test. If results differ from what is stated above, inspect the installation and program parameters. Make corrections as needed.

## 11.1.5 Lift Axle Label

The lifting and lowering pressures should be clearly written with indelible ink on label TP09174. This label should be affixed near the lift axle on the trailer body by the trailer's original equipment manufacturer. Figure 11.20.

Fig. 11.20

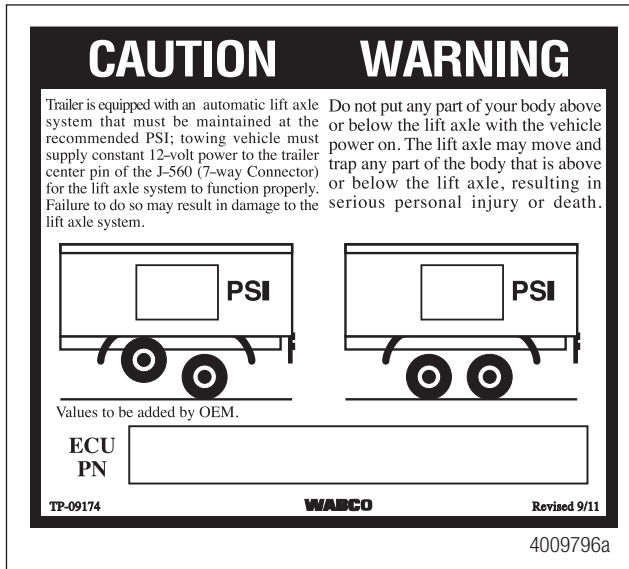

## 11.2 Tag Axle Troubleshooting

A tractor with a Tag Axle activation switch installed is required.

The first step taken when troubleshooting the Tag Axle system is to ensure that the system is pneumatically plumbed and electrically connected correctly. Refer to Figures 9.9, 9.10 and 9.11 in this section for the correct schematic, depending upon the configuration.

For additional information, refer to installation manual TP1034, Tag Axle Installation for RSS*plus*, available at [wabco-auto.com](http://wabco-auto.com).

When testing the Tag Axle system, ensure the trailer is supplied with 100-120 psi air pressure to the supply air and 12 volts DC power rated at a minimum of 10 amps to the trailer's constant power circuit.

Use of a volt-ohm meter may be required.

This troubleshooting section is based on the use of TOOLBOX™ Software version 12.2 or higher. If you have an earlier version of software, visit [wabco-auto.com](http://wabco-auto.com) or contact your Snap-On dealer.

# Troubleshooting

Condition Experienced	Action to Take	Troubleshooting Details
Tag Axle Function Will Not Activate	Cycle trailer power.	ECU valve should audibly click during its power-up self-test. ABS warning light will illuminate and extinguish as a light test. If warning light remains on, begin diagnostics with TOOLBOX™ Software. If the ECU fails to click, ensure that the sensor extension cables are securely attached to the ECU and ensure that 12 volts is present at pin 1 on the ECU power connector. Refer to Figure 11.21.
	Retrieve diagnostic information via TOOLBOX™ Software.	If warning light is on, begin diagnostics with TOOLBOX™ Software. Repair and clear all faults found.
	Ensure no other TIO files have been loaded into the ECU.	In TOOLBOX™ Software under the Modify pull down, select the Notebook feature. Verify that only the tag axle TIO file has been activated or loaded. The tag axle TIO file is named "T_00102a.TIO".
	Ensure the tag axle system is plumbed correctly.	Refer to Figures 11.22 and 11.23.
	Inspect the cab-mounted tag axle toggle switch.	Using an ohm meter, verify the switch functionality. Switch should be a single-pole, single-throw toggle switch. Refer to the switch manufacturer's documentation for electrical contact information. 12v DC should be present when the switch is in the ON position and 0v DC when the switch is in the OFF position.
	Verify toggle switch installation.	The cab-mounted toggle switch is connected to 12v tractor power. The black wire from the switch cable 449 711 150 0 is connected to the switch contact opposite the 12v tractor power. The brown wire is unused and capped. Refer to Figures 11.22 and 11.23.
	Verify switch output.	Using a volt/ohm meter, check the switch for correct operation and functionality.
	Verify 12v analog input cable is correctly connected to the generic I/O cable 449 442 010 0.	Ensure the switch cable 449 711 150 0 is securely fastened to the "A1" lead of the generic I/O cable 449 866 010 0.
	Verify the 12v analog input cable 449 428 030 0 integrity.	Using a volt/ohm meter, check for shorted or open circuits on the 12v analog input cable. Refer to Figure 11.24.
Verify the operation of the 3/2 solenoid valve 472 170 997 0.	Apply 12v DC power and ground to pins 1 and 2 in the 3/2 valve's bayonet connector. The solenoid should energize and dump the air on the tag axle. Removing the power and ground will cause the tag axle air bags to re-inflate. Figure 11.25.	

# Troubleshooting

Condition Experienced	Action to Take	Troubleshooting Details
	Check 3/2 solenoid valve cable 449 518 010 0 integrity.	Using a volt/ohm meter, check for shorted or open circuits on the solenoid valve cable. Refer to Figure 11.26.
	Verify generic I/O cable 449 442 866 0 is correctly hooked up.	Refer to Figures 11.22 and 11.23. Ensure that lead "LS" is unused and correctly capped.
	Check generic I/O cable 449 866 010 0 integrity.	Using a volt/ohm meter, check for shorted or open circuits on the multiple I/O cable 449 866 010 0. Refer to Figure 11.27.
Tag Axle Will Not Reset	Using TOOLBOX™ Software, ensure there are no active faults.	Repair and clear all active faults. Cycle the ECU power.
	Ensure the tag axle system is plumbed correctly.	Refer to Figures 11.22 and 11.23.
	Verify ECU is reading wheel speed.	Using TOOLBOX™ Software, perform the Sensor Test from the Component Tests pull down.
	Inspect the cab-mounted tag axle toggle switch.	Using an ohm meter, verify the switch functionality. Switch should be a single-pole, single-throw toggle switch. Refer to the switch manufacturer's documentation for electrical contact information.
	Verify toggle switch installation.	The cab-mounted toggle switch is connected to 12v tractor power. The black wire on the activation switch cable 449 711 150 0 (with indicator lamp) or the blue wire on the "Y" cable 449 810 148 0 (without indicator lamp) is connected to the switch contact opposite the 12v tractor power. See Figures 11.22 and 11.23. The remaining wire from either cable is unused and capped.
	Verify switch output.	Using a volt/ohm meter, check the switch for correct operation and functionality.
	Verify 12v activation switch cable is correctly connected to the generic I/O cable 449 866 010 0.	Ensure the 12v activation switch cable 449 711 150 0 is securely fastened to the "A1" lead of the generic I/O cable 449 866 010 0.
	Verify the 12v activation switch cable 449 711 150 0 integrity.	Using a volt/ohm meter, check for shorted or open circuits on the 12v activation switch cable. See Figure 11.29.
	Verify the operation of the 3/2 solenoid valve 472 170 997 0.	Apply 12v DC power and ground to pins 1 and 2 in the 3/2 valve's bayonet connector. The solenoid should energize and dump the air on the tag axle. Removing the power and ground will cause the tag axle air bags to re-inflate.

# Troubleshooting

Condition Experienced	Action to Take	Troubleshooting Details
Tag Axle Comes to Rest on Axle Bump Stops	Using TOOLBOX™ Software, ensure there are no active faults.	Repair and clear all active faults. Cycle the ECU power.
	Ensure tag axle system is plumbed correctly.	Refer to Figures 11.22 and 11.23.
	Verify the 3/2 solenoid valve has optional components installed.	Refer to Figure 11.28.
	Check for air leaks.	Ensure no air leaks at the 1/4" to 3/8" adapter, the residual pressure valve and the breather valve. Refer to Figure 11.28.
Tag Axle is Intermittent	Using TOOLBOX™ Software, ensure there are no active faults.	Repair and clear all active faults. Cycle the ECU power.
	Verify tag axle system is plumbed correctly and check for air leaks.	Refer to Figures 11.22 and 11.23.
	Ensure that the air volume capacity of the trailer meets trailer OEM standards for operating a tag axle.	Verify the output of the towing vehicle's air compressor to the trailer.
Optional Tag Axle Indicator Light Does Not Function	Using TOOLBOX™ Software, ensure there are no active faults.	Repair and clear all active faults. Cycle the ECU power.
	Verify the type of tag axle 12 volt DC indicator lamp.	The lamp must be an incandescent lamp or a load-resistored LED lamp.
	Verify the lamp is correctly wired to the light output cable 449 711 120 0.	The black wire is hooked to power and the brown wire is hooked to ground.
	Verify the integrity of light output cable 449 711 150 0.	Using a volt/ohm meter, check for shorted or open circuits on the light output cable. Refer to Figure 11.29.
	Verify the generic I/O cable 449 866 010 0 integrity.	Using a volt/ohm meter, check for shorted or open circuits on the "D1" lead of the generic I/O cable. Refer to Figure 11.27.
Optional Tag Axle LED Indicator Lamp Stays on Faintly	Inspect the type of indicator lamp.	Replace generic LED lamp with a load-resistored LED or incandescent lamp. The black wire is hooked to power and the brown wire is hooked to ground.

Fig. 11.21

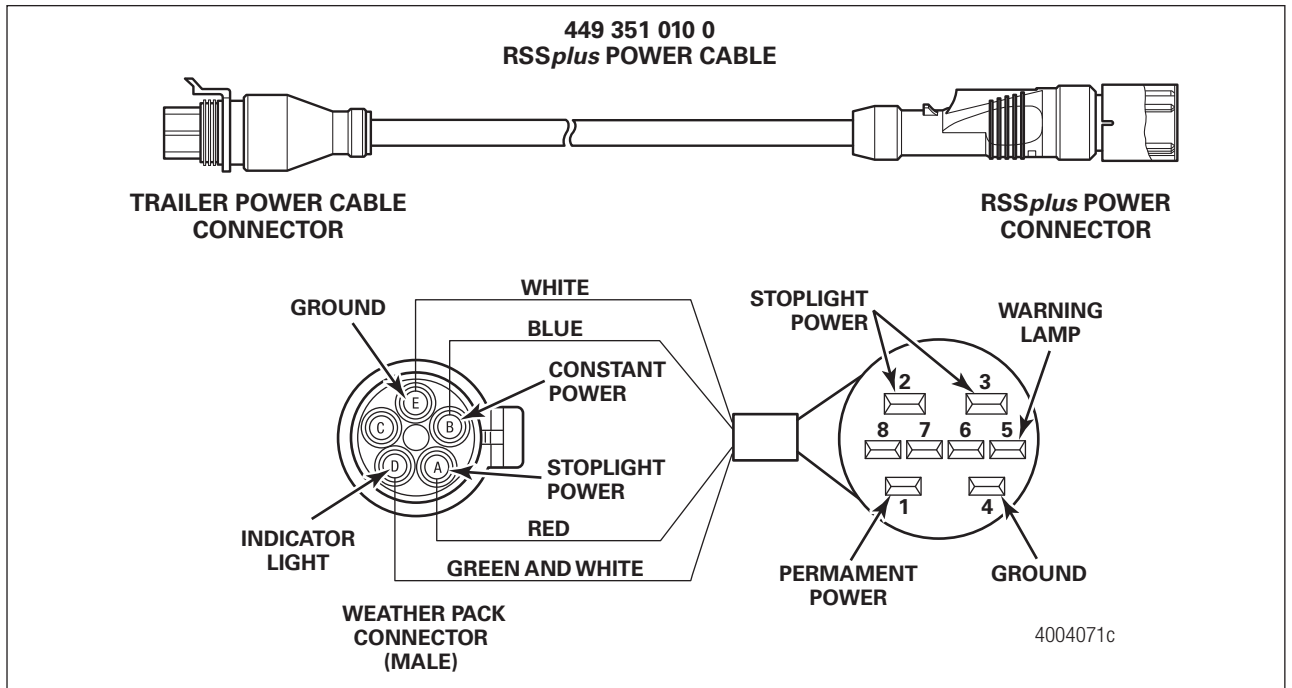



Fig. 11.22

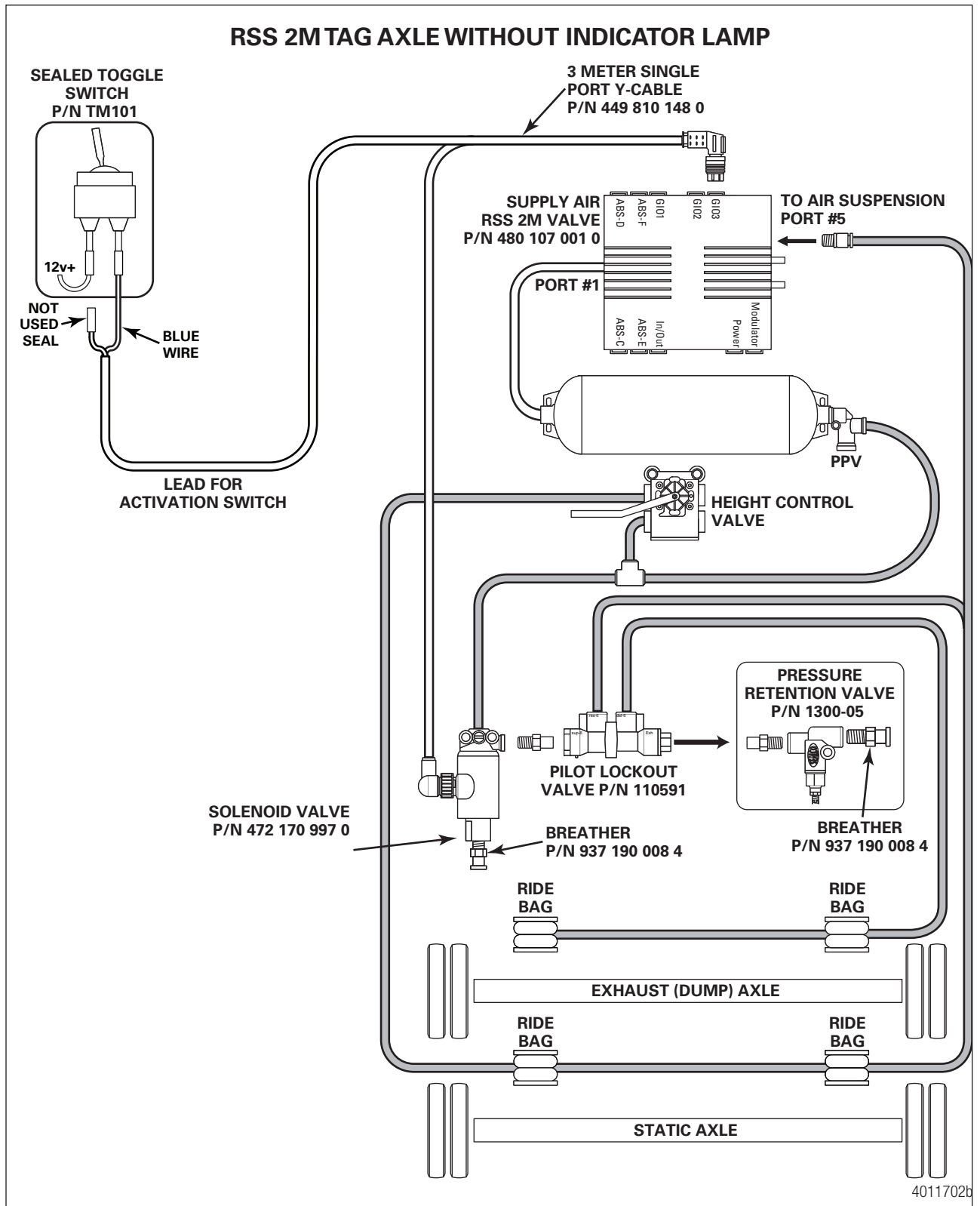

Fig. 11.23

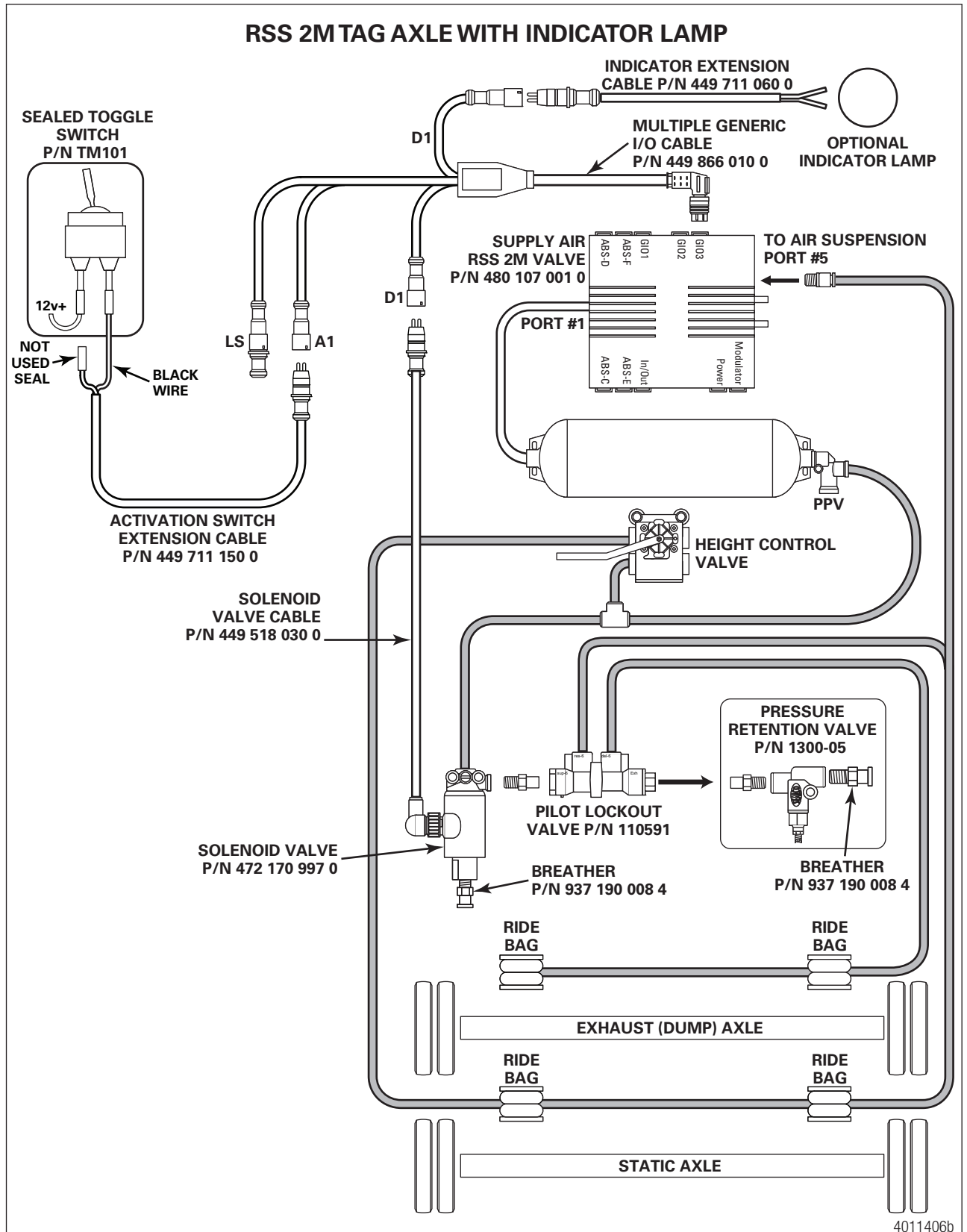

Fig. 11.24

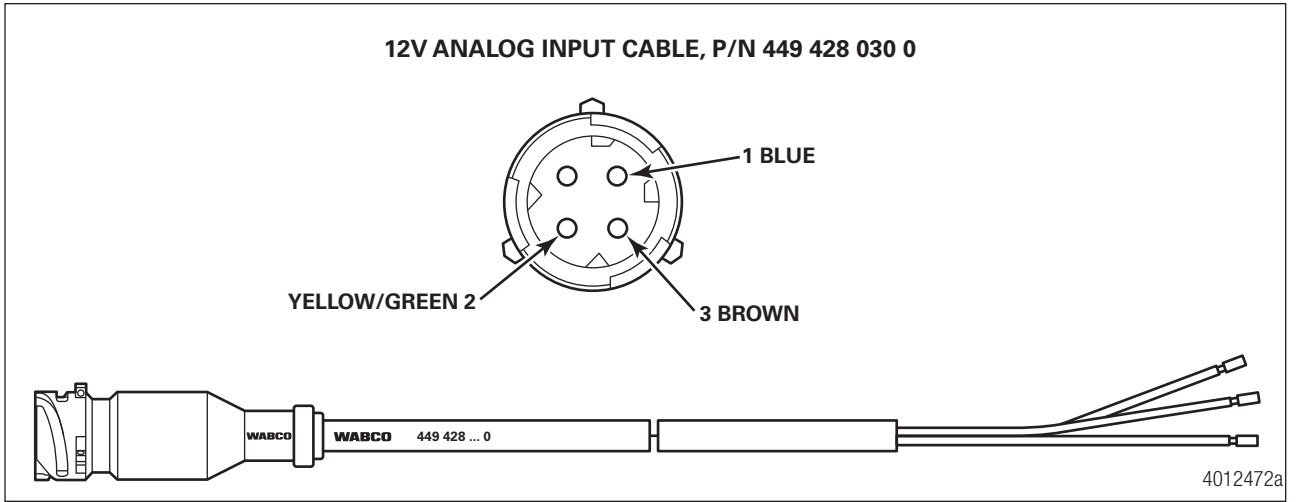

Fig. 11.25

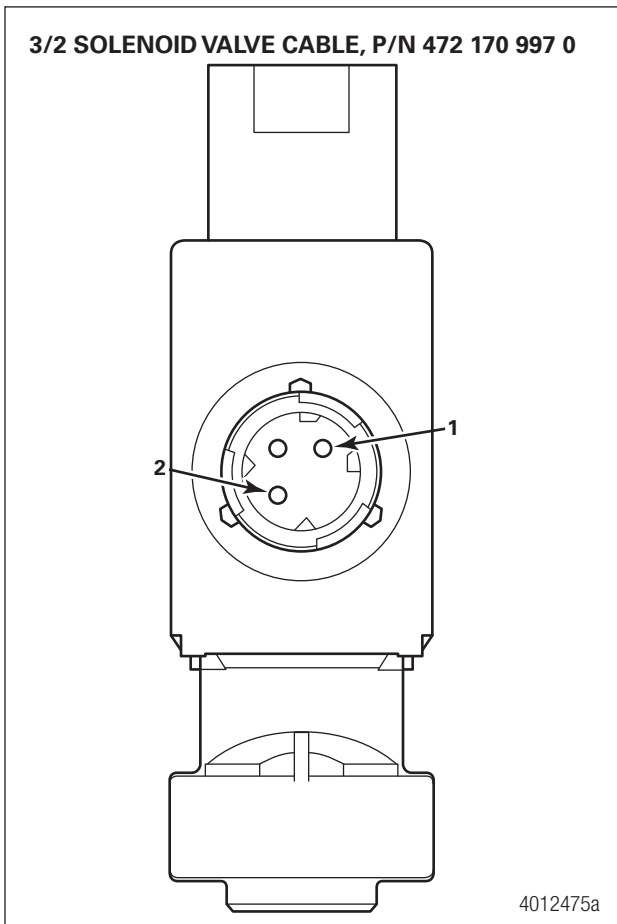

Fig. 11.26

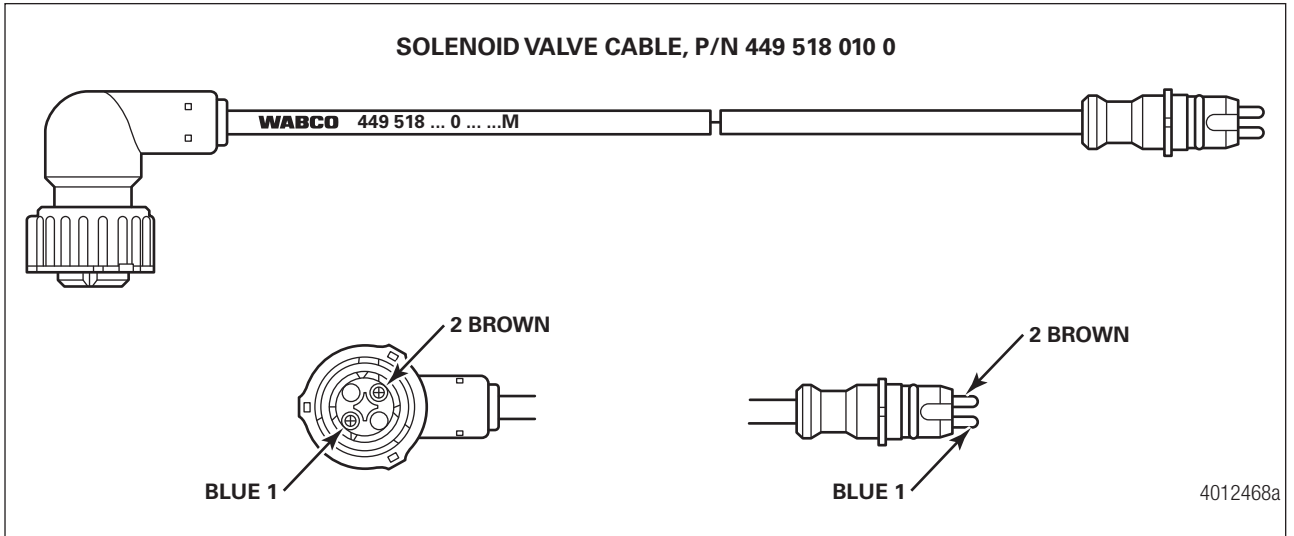

Fig. 11.27

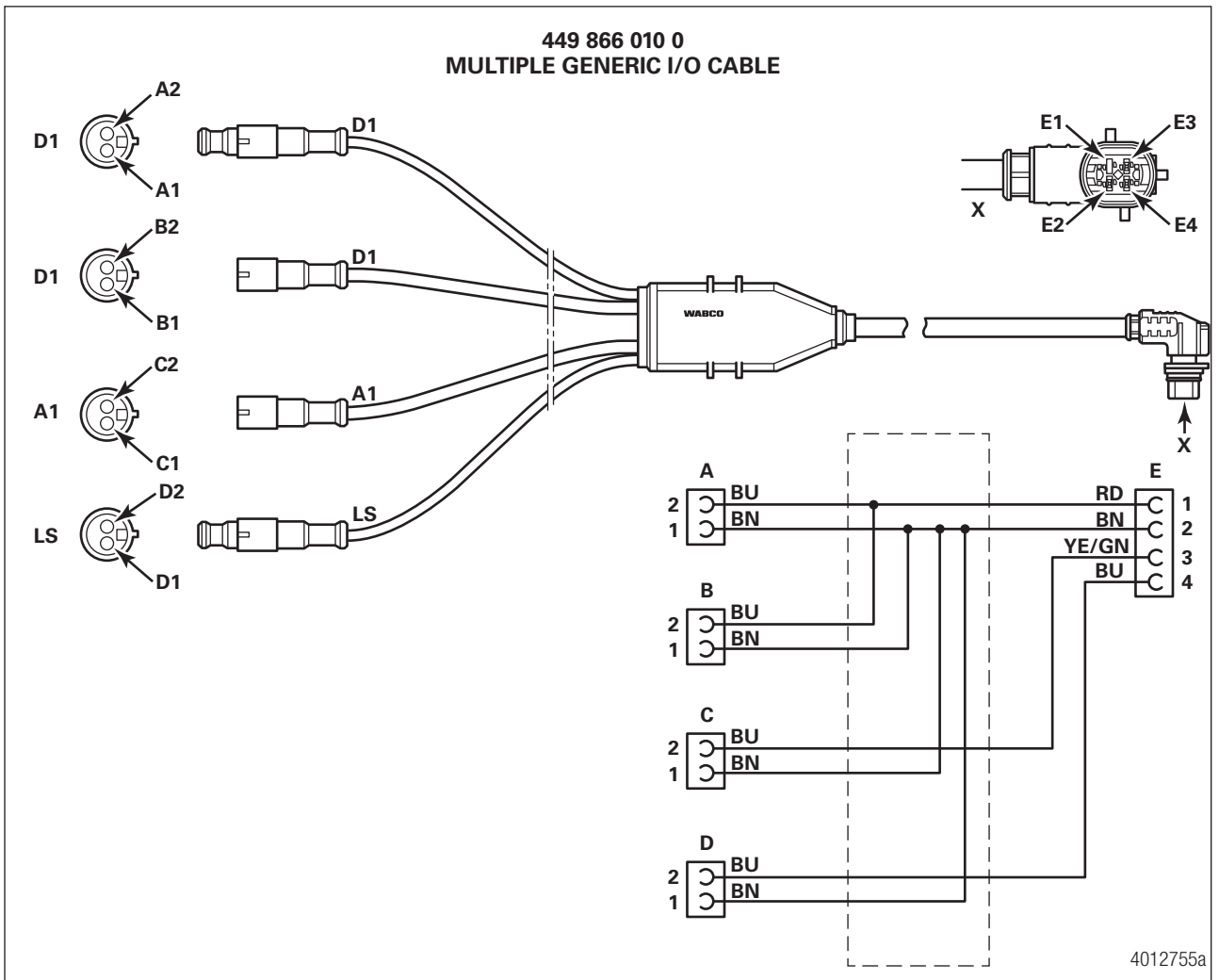

Fig. 11.28

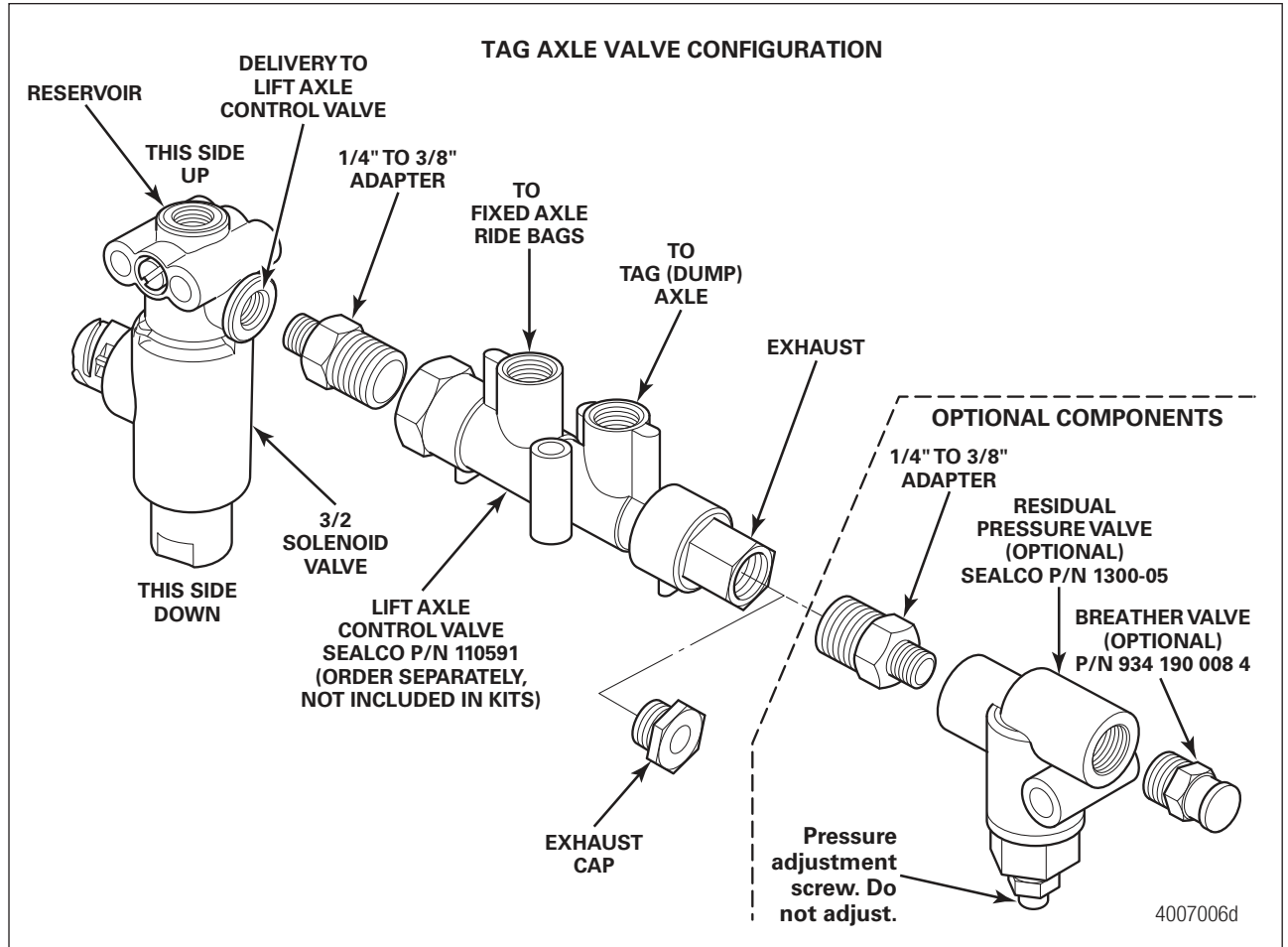
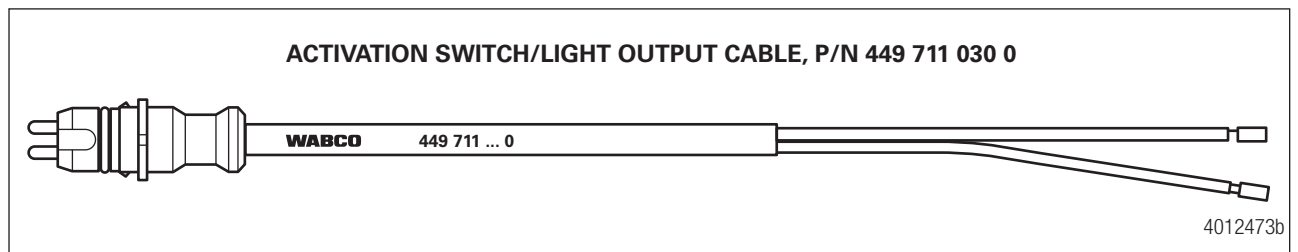

Fig. 11.29



## 11.2.1 Activating the Tag Axle Option with TOOLBOX™ Software

Once the hardware has been installed, the Generic I/O Tag Axle option must be activated using WABCO TOOLBOX™ Software version 12.2 or later.

After Generic I/O activation, the End-of-Line test must be completed for new builds or new ECU replacement. Refer to the procedures in this manual or Installation Guide TP0887, Trailer ABS with Roll Stability Support (RSSplus™) for Trailers with Air or Mechanical Suspensions, for step-by-step instructions on programming and conducting the End-of-Line test.

1. Enter the Roll Stability portion of TOOLBOX™ Software. From the top menu bar, go to the System pull-down menu and select Edit Parameters from ECU. Figure 11.30.

Fig. 11.30

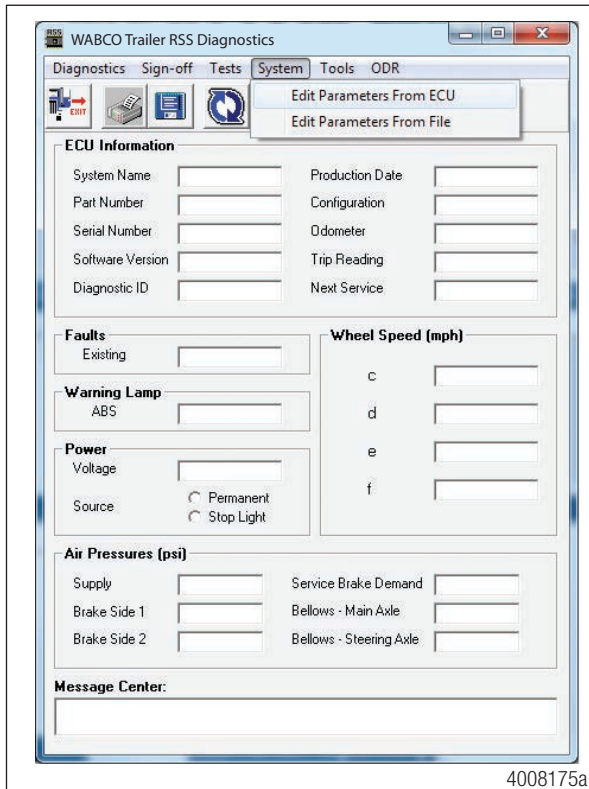

2. From the first parameter screen labeled RSS System Parameters, press the Next button located at the bottom of the window. There is no change in parameters at this screen. Figure 11.31.

Fig. 11.31

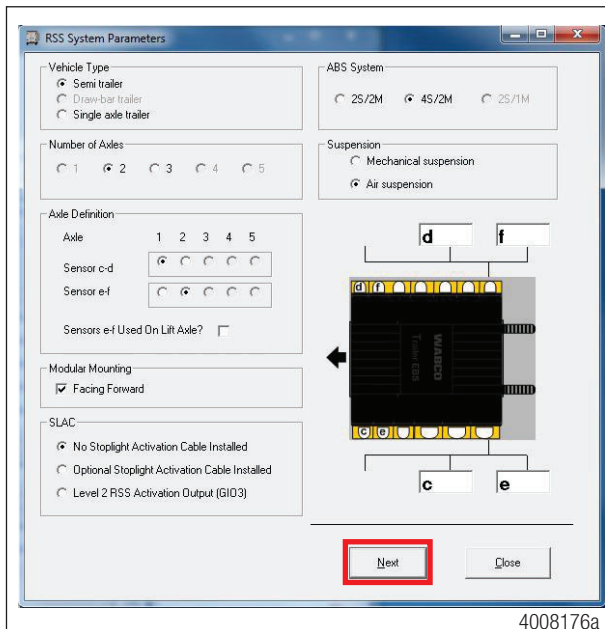

- The GIO Selection screen appears. Click the Tag Axle (Rear Suspension Dump) check box. Ensure that a check mark appears in the box. Then, press the Next button at the bottom of the screen. Figure 11.32.

Fig. 11.32

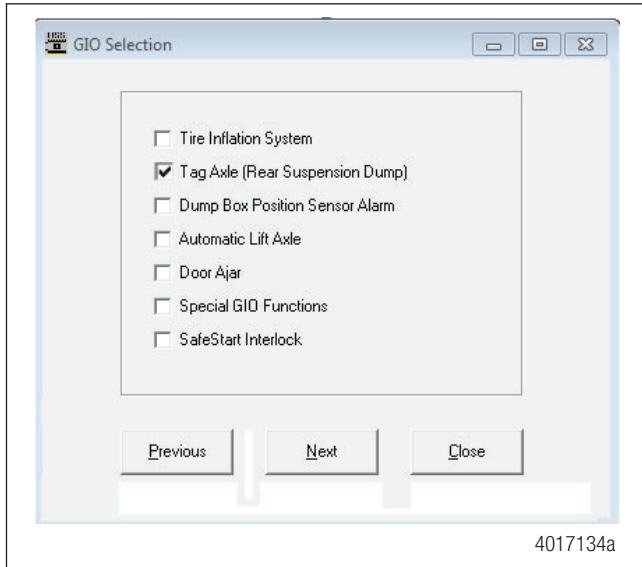

- From the parameter screen labeled RSS LSV Parameters, press the Next button located at the bottom of the window. There is no change in parameters at this screen. Figure 11.33.

Fig. 11.33

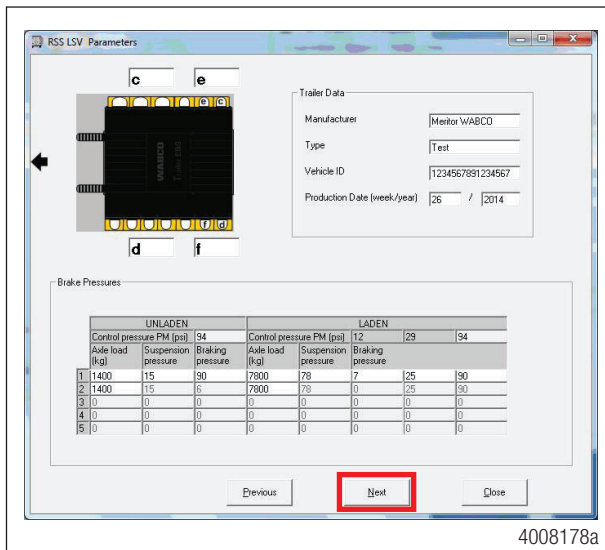

5. From the parameter screen labeled RSS / ABS Parameters, press the Save To ECU button located at the bottom of the window. There is no change in parameters at this screen. Figure 11.34.



Ensure that "RSS On - Twin Tires" or "RSS On - Single Tires" is selected.

Fig. 11.34

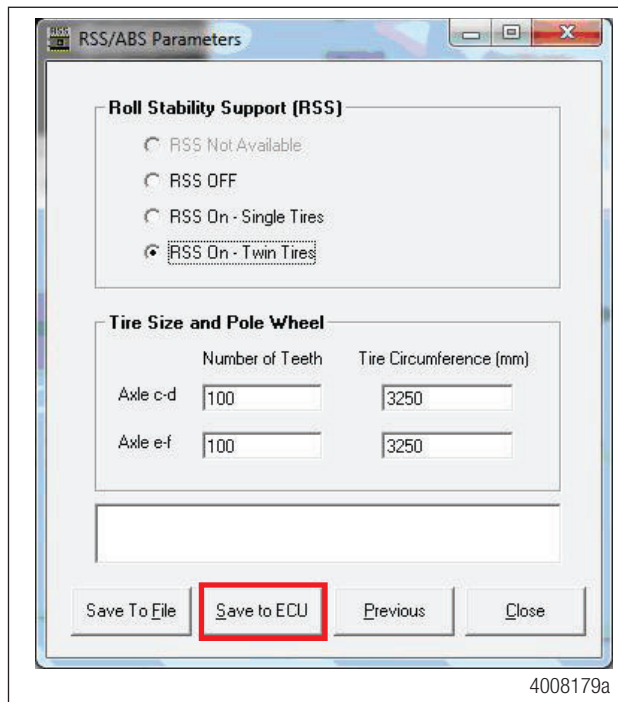

6. Once a message appears confirming a successful save, you may exit the TOOLBOX™ Software. Be sure to reset the power on the trailer in order to recycle the ECU. An End-Of-Line test is not required on a previously programmed ECU.

## 11.3 Tire Inflation Communication System Troubleshooting

Refer to TP1087, Tire Inflation Communication System Manual found at [wabco-auto.com](http://wabco-auto.com).

The first step taken when troubleshooting the Tire Inflation Communication System is to ensure that the system is electrically connected correctly. Refer to Figure 11.36.



If the Tire Inflation System status lamp is not present or is not functioning, then the Tire Inflation Communication System will not function.

This troubleshooting section is based on the use of TOOLBOX™ Software version 12.2 or higher. If you have an earlier version of TOOLBOX™ Software, visit [wabco-auto.com](http://wabco-auto.com) or contact your Snap-On dealer.



# Troubleshooting

Condition Experienced	Action to Take	Troubleshooting Details
Tire Inflation System LED Illuminates with a Dim Glow All the Time	Confirm the Tire Inflation System LED is an incandescent or LED with resistor part number 31263-20.	Replace light as necessary. Ensure light is correctly grounded.
WABCO Tire Inflation Communication System is not Broadcasting a "Low Tire Pressure" Message When There is a Fill Event and the Tire Inflation System Light is Illuminated	Correct installation needs to be verified.	Confirm WABCO Tire Inflation Communication System is installed per Figures 11.37, 11.38 and 11.39. Make sure all electrical connections are fully seated.
	ECU valve should audibly click during its power-up self-test.	Ensure that 12 volts is present across pin 1 and (pin 4) on the ECU power connector. Figure 11.21.
	Check continuity of the I/O cable.	Check continuity for the XXX X generic I/O cable. Refer to Figure 11.35.
	Check diode cable.	Check diode on pre-installed Tire Inflation System cable pigtail. Place the volt/ ohm meter to "Diode". Place red lead on single male pin. Place the black lead on the dual tab connector. Continuity should be observed on the volt/ohm meter. Switching the leads in the opposite direction, an "Open" should be displayed on the volt/ ohm meter. Refer to Figure 11.36.
	Confirm Tire Inflation System has been activated in the ECU.	From the Roll Stability portion of the TOOLBOX™ Software, select the System pull-down. Select Edit Parameters from ECU. Press the Next button. Ensure the box next to Tire Inflation System is checked. Press Close and then exit the TOOLBOX™ Software. If the T.I.S. is not checked, proceed to Activating the Tire Inflation System in this section.
"Low Tire Pressure" Message is Being Broadcasted All the Time	Correct installation needs to be verified.	Confirm WABCO Tire Inflation Communication System is installed per Figures 11.37, 11.38 and 11.39. Make sure all electrical connections are fully seated.
	Confirm the Tire Inflation System LED is an incandescent or LED with resistor part number 31263-20.	Replace light as necessary. Ensure light is grounded.
Tire Inflation System LED Does Not Illuminate During a Fill Event	Correct installation needs to be verified.	Confirm Tire Inflation System is installed per MM14P. Confirm Tire Inflation System LED is not burned out. Replace Tire Inflation System LED as required with part number 31263-20.

Condition Experienced	Action to Take	Troubleshooting Details
The Parameter File T_0109b.tio Has Been Successfully Downloaded to the ECU, but Tire Inflation System Message is Not Being Broadcasted	Confirm T_0109b.tio is visible in the "Notebook" section of TOOLBOX™ Software 12.2 or higher.	Call the WABCO Customer Care Center at 855-228-3203.

Fig. 11.35

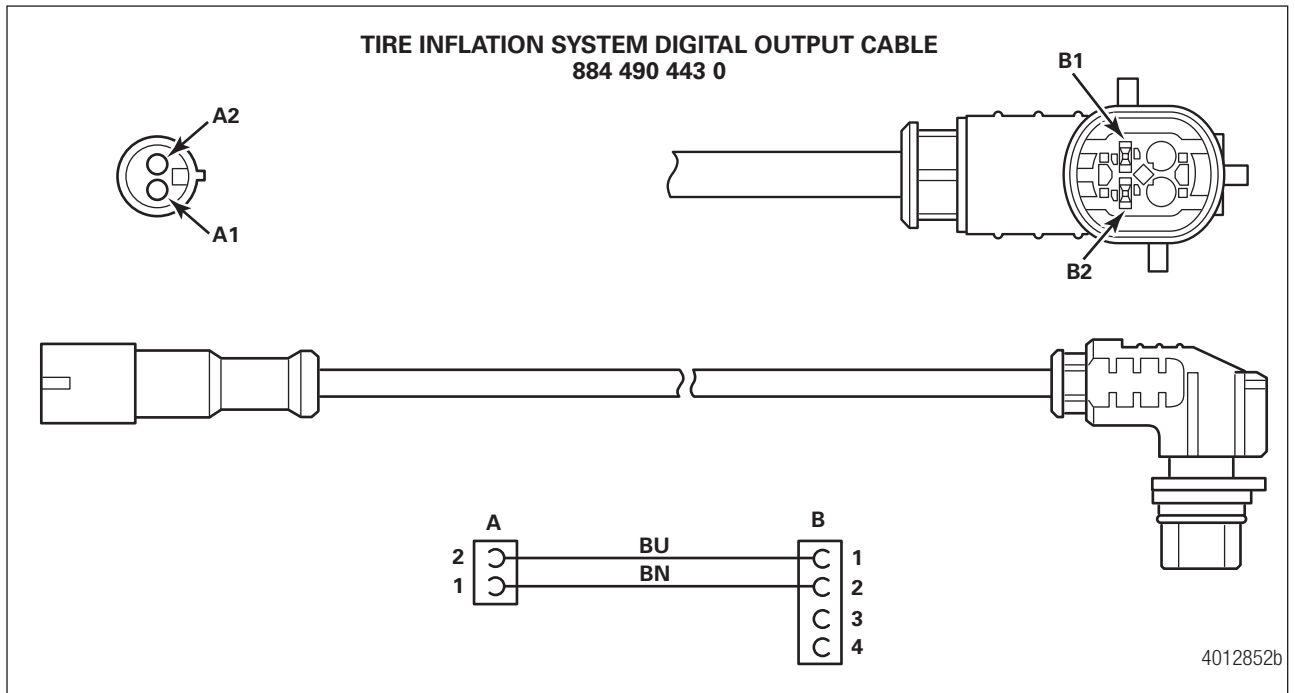

Fig. 11.36

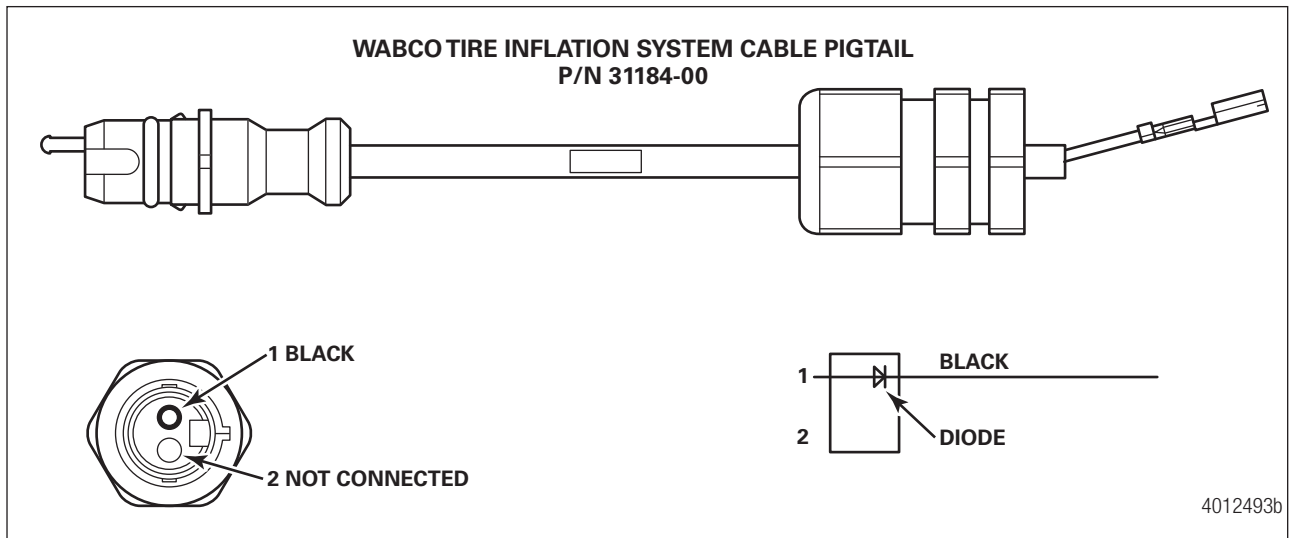

Fig. 11.37

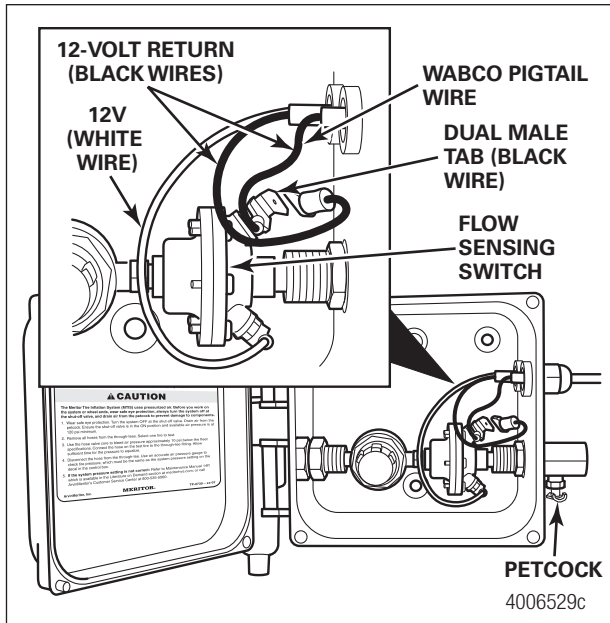

Fig. 11.38

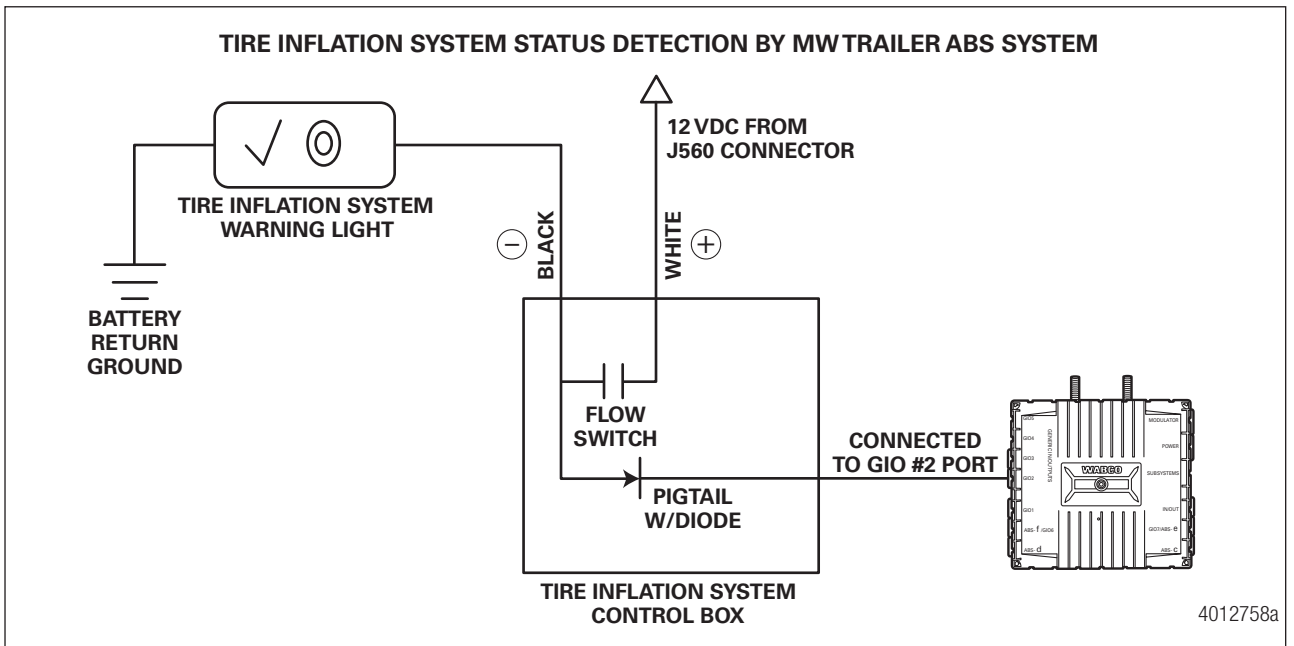
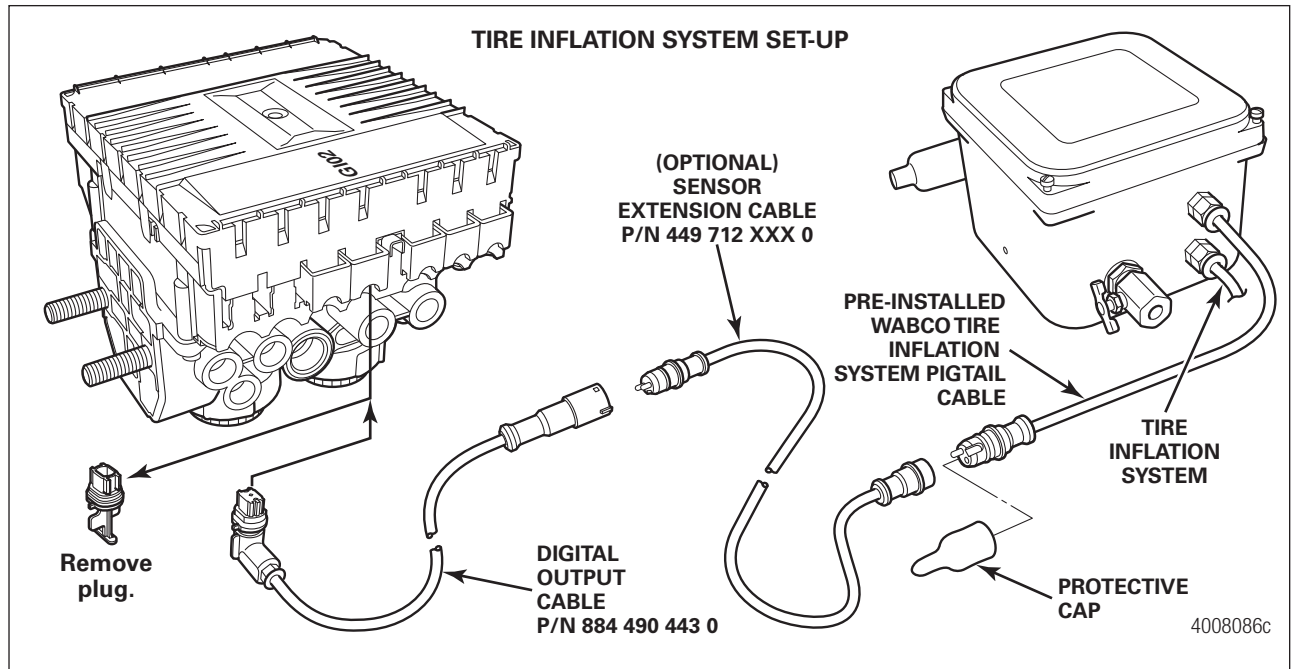

Fig. 11.39



## 11.3.1 Activating the Tire Inflation Option with TOOLBOX™ Software

Once the hardware has been installed, the Tire Inflation Option must be activated using WABCO TOOLBOX™ Software version 12.2 or later. When installing the Tire Inflation Option on new or replacement ECUs, the activation process is part of your normal programming procedure. Refer to the procedures in this manual or Installation Guide TP0887, Trailer ABS with Roll Stability Support (RSS<sup>plus</sup>™) for Trailers with Air or Mechanical Suspensions, for step-by-step instructions on programming and conducting the End-of-Line test.

# Troubleshooting

1. Enter the Roll Stability portion of TOOLBOX™ Software. From the menu bar at the top, choose the System pull-down menu and select Edit Parameters From ECU. Figure 11.40.

Fig. 11.40

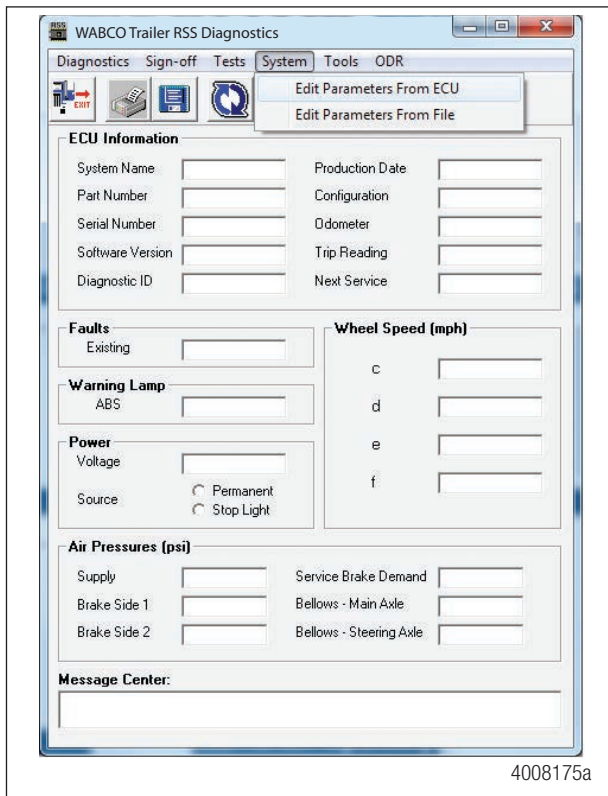

2. From the first parameter screen labeled RSS System Parameters, press the Next button located at the bottom of the window. There is no change in parameters at this screen. Figure 11.41.

Fig. 11.41

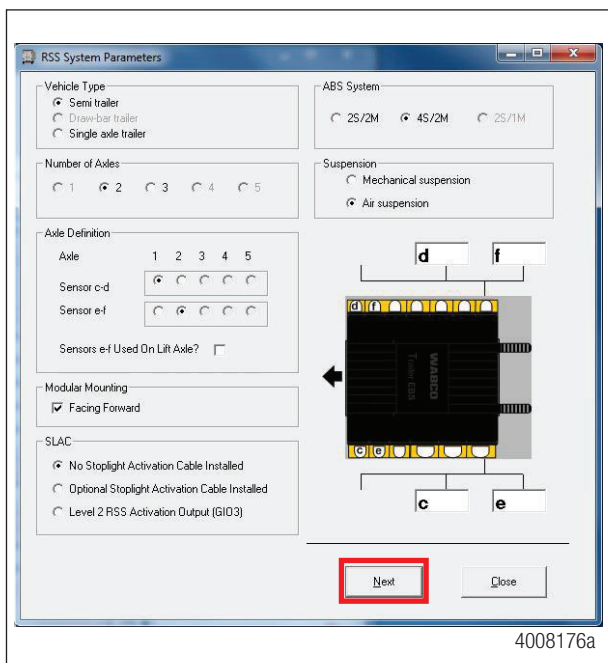

- The GIO Selection screen appears. Click on the box adjacent to the label Tire Inflation System. Ensure that a check mark appears in the box. Then press the button labeled Next at the bottom of the screen. Figure 11.42.

Fig. 11.42

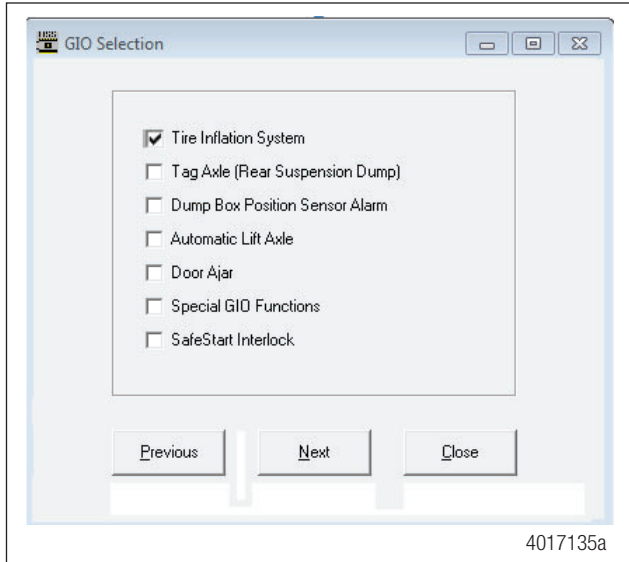

- From the parameter screen labeled RSS LSV Parameters, press the Next button located at the bottom of the window. There is no change in parameters at this screen. Figure 11.43.

Fig. 11.43

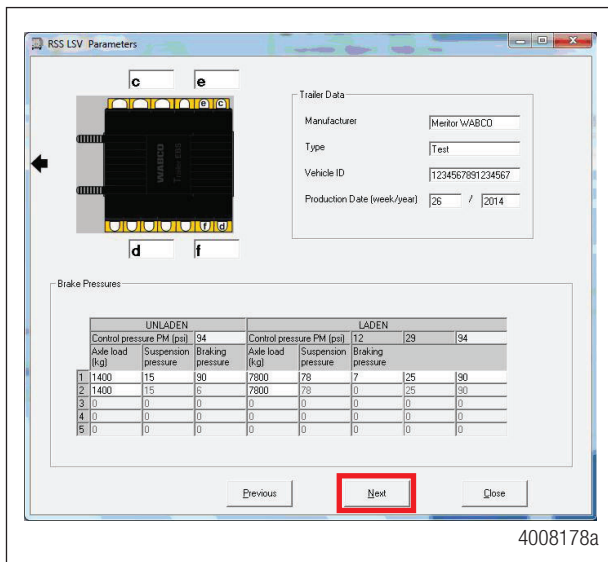

- From the parameter screen labeled RSS / ABS Parameters, press the Save To ECU button located at the bottom of the window. There is no change in parameters at this screen. Figure 11.44.



Ensure that "RSS On - Twin Tires" or "RSS On - Single Tires" is selected.

Fig. 11.44

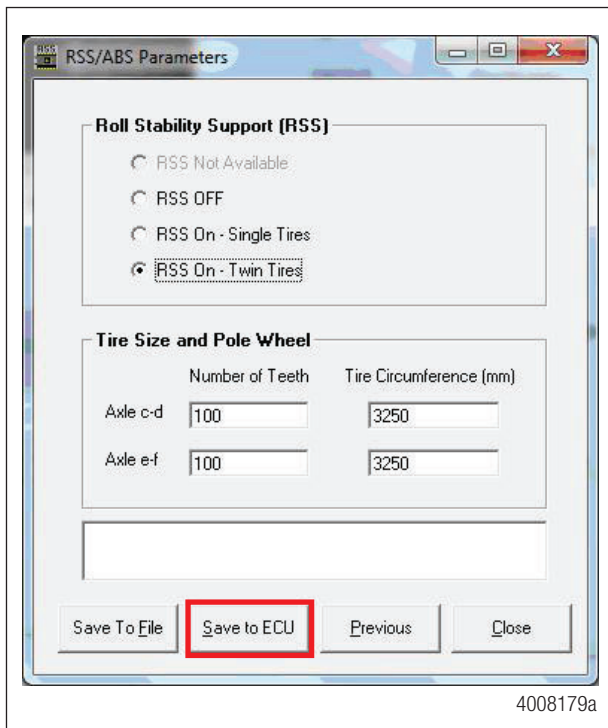

- Once a message is displayed confirming a successful save, you may exit the TOOLBOX™ Software. Be sure to cycle the power on the trailer in order to reset the ECU. An End-Of-Line test is not required on a previously programmed ECU.

## 11.4 Door Ajar System with RSSplus Troubleshooting



ECU part numbers 480 107 001 0 and 480 107 000 0 are the RSSplus™ valve that have Door Ajar System functionality.

The first step taken when troubleshooting the Door Ajar System is to ensure that the system electrical cables are connected correctly. Refer to Figure 11.45, Figure 11.46 and Figure 11.47 in this section for parts and the correct schematic, depending upon the configuration.

For additional information, refer to TP17132, Installing and Configuring the WABCO Trailer RSSplus™ with Tire inflation and Door Ajar Systems, found at [wabco-auto.com](http://wabco-auto.com).

This troubleshooting section is based on the use of TOOLBOX™ Software version 12.5 or higher. If you have an earlier version of TOOLBOX™ Software, visit <https://wabco.snapon.com/> or contact your Snap-On dealer.

## Troubleshooting

Condition Experienced	Action to Take	Troubleshooting Details
Door ajar system is not broadcasting a "Door Ajar" message when the trailer door is open.	Correct installation needs to be verified.	Confirm WABCO Door Ajar System is installed per Figure 11.45, Figure 11.46 and Figure 11.47. Make sure all electrical connections are fully seated.
	ECU valve should audibly click during its power-up self-test.	Ensure that 12 volts is present across pin 1 and pin 4 on the ECU power connector.
	Check continuity of the I/O cable.	Check continuity for the XXX X generic I/O cable. Refer to Figure 11.35.
	Check proximity switch part number 446 147 XXX 4.	An volt/ohm meter must be used to check the proximity switch, part number 446 147 XXX 4. Figure 11.47. Make sure the ohm meter shows more than 1 MΩ when magnets are actuated (access point is closed) and less than 1Ω when access point is open. Also the gap between the mating connector to enable correct NO NC contact should be less than 2.5 inches (64 mm).
	Confirm Door Ajar System has been activated in the ECU.	From the Roll Stability portion of the TOOLBOX™ Software, select the System pull-down. Select Edit Parameters from ECU. Press the Next button. Ensure the box next to Door Ajar is checked. Press Close and then exit the TOOLBOX™ Software. If the Door Ajar is not checked, proceed to Activating the Door Ajar System in this section.
"Door Ajar" message is being broadcasted all the time.	Correct installation needs to be verified.	Confirm WABCO Door Ajar System is installed per Figure 11.45, Figure 11.46 and Figure 11.47. Make sure all electrical connections are fully seated.
"Door Ajar" message is not broadcasted on the telematics display.	Contact the telematics provider.	Since WABCO does not provide telematics unit, please contact the telematics provider.
The Parameter File "Tire inflation & Door ajar.tio" has been successfully downloaded to the ECU, but Door Ajar System message is not being broadcasted.	Confirm "Tire inflation & Door Ajar.tio" is visible in the "Notebook" section of TOOLBOX™ Software 12.5 or higher.	Call the WABCO Customer Care Center at 855-228-3203.



Fig. 11.45

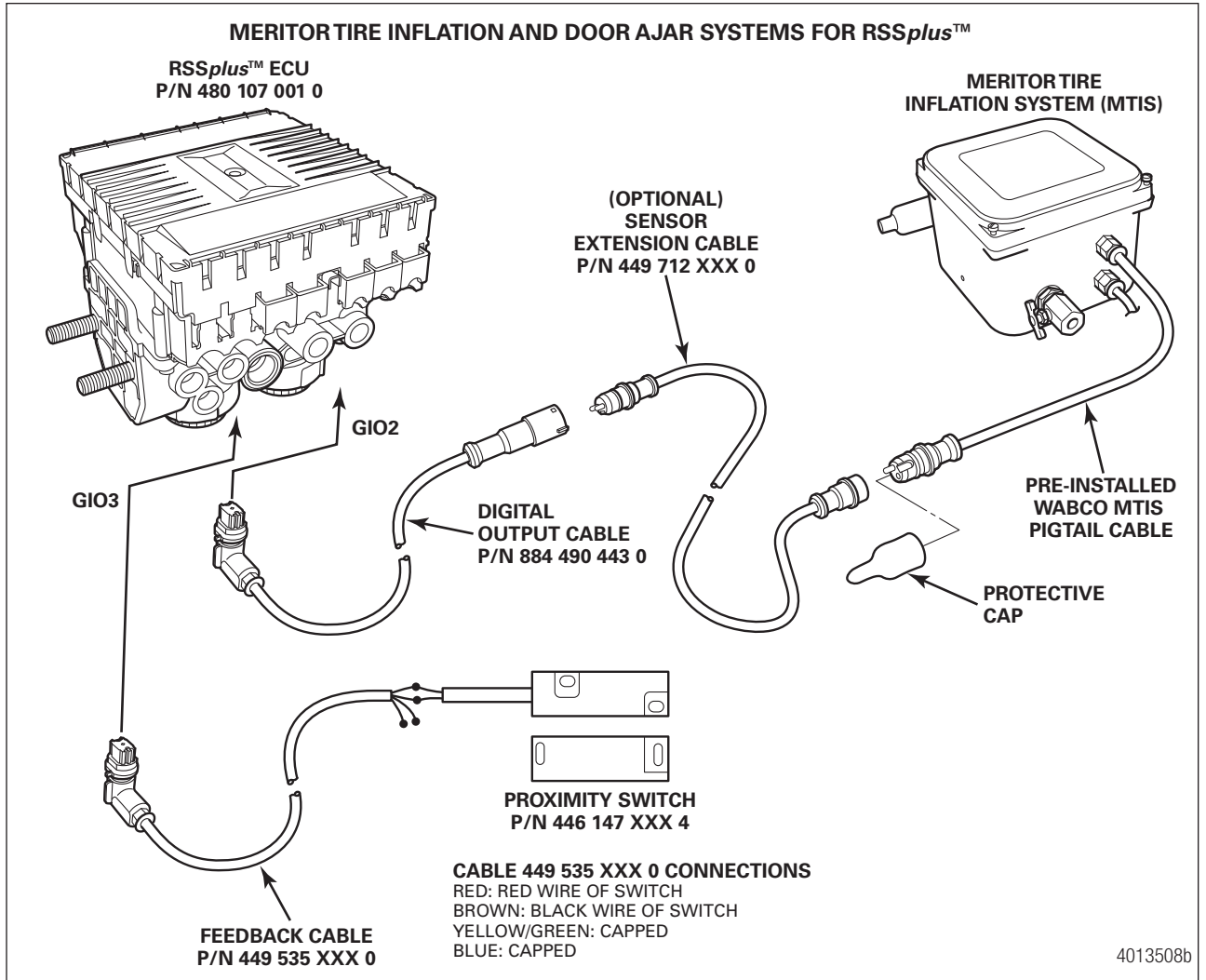

Fig. 11.46

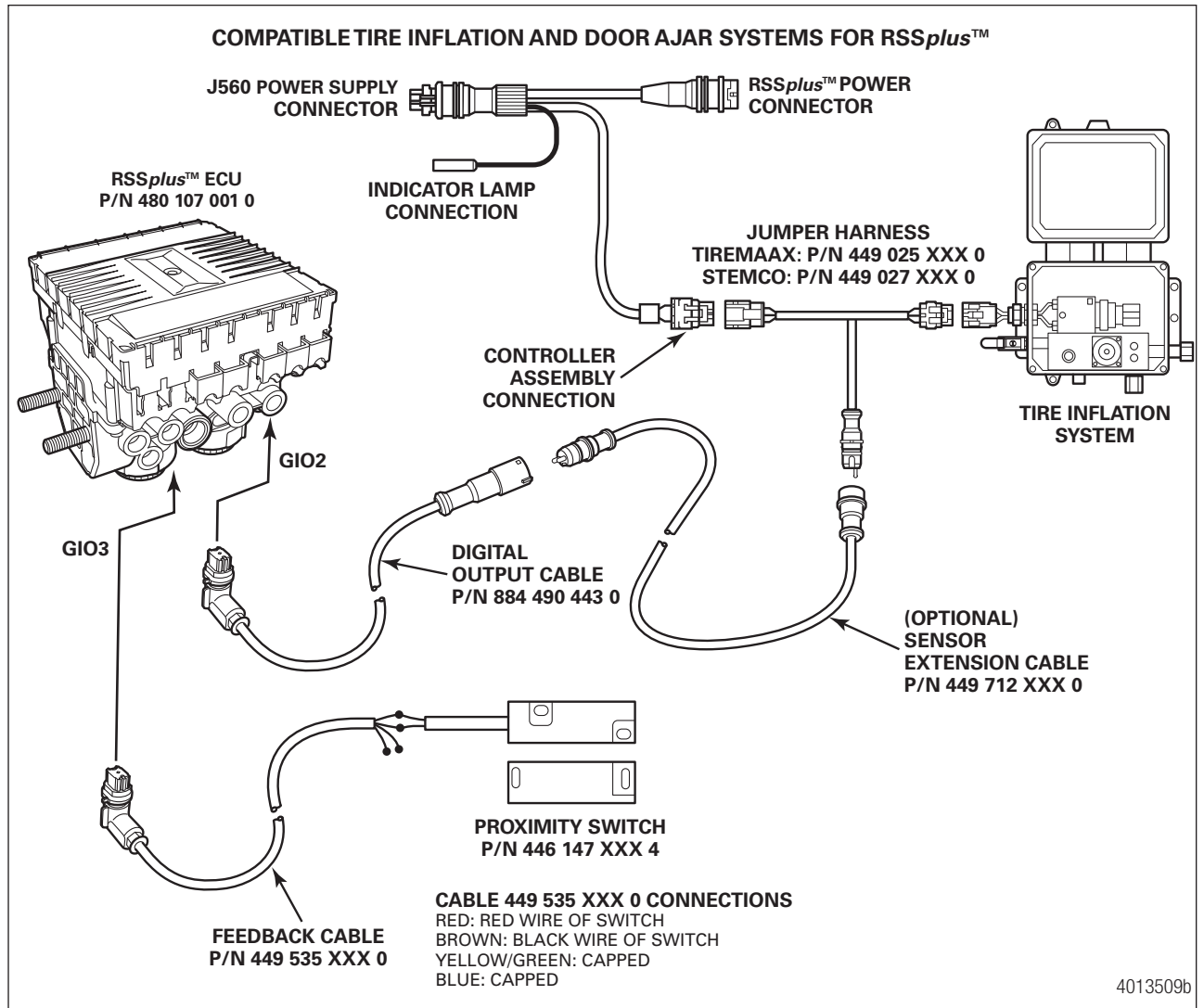
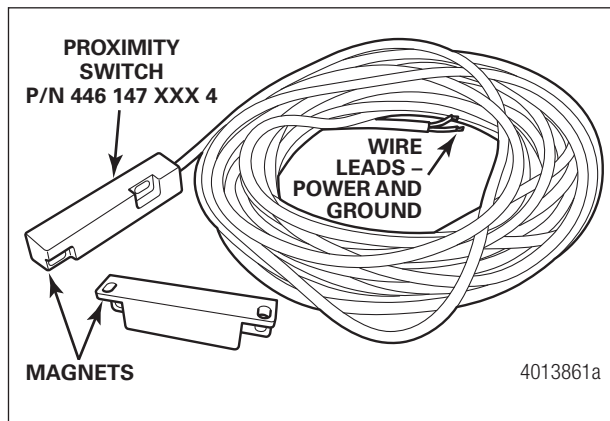

Fig. 11.47



## 11.4.1 Activating the Tire Inflation and Door Ajar Systems Option with TOOLBOX™ Software

Once the hardware has been installed, both the Tire Inflation System and Door Ajar options must be activated using WABCO TOOLBOX™ Software version 12.5 or later. When installing Tire Inflation and Door Ajar Systems option on new or replacement ECUs, the activation process is part of the normal programming procedure. Refer to Installation Guide TP0887, Trailer ABS with Roll Stability Support (RSS<sub>plus</sub>™) for Trailers with Air or Mechanical Suspensions, or Maintenance Manual MM0888, RSS<sub>plus</sub>™ Trailer ABS with Roll Stability Support, for step-by-step instructions on programming and conducting the End-of-Line test.

1. Click the TOOLBOX icon on the desktop and then click the J1708/PLC icon. For TOOLBOX Plus, Select Trailer RSS (Roll Stability) in the left menu Under Trailer (PLC)/J1708/CAN. Figure 11.48.

Fig. 11.48

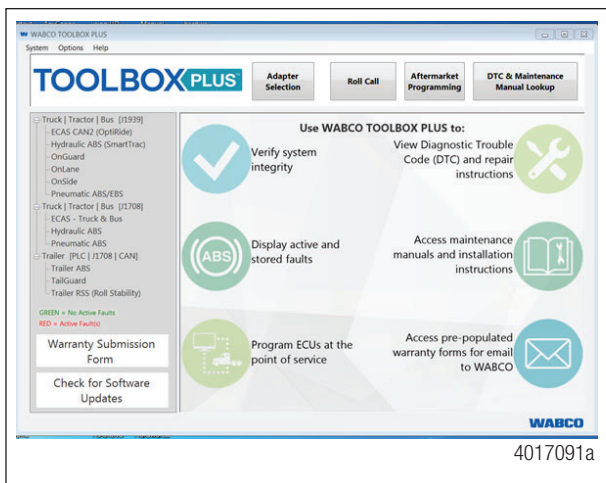

2. Click on the RSS icon to initiate the Roll Stability System portion of TOOLBOX™ Software. Figure 11.49.

 To enable trailer and TOOLBOX™ Software communication, make sure the correct adapter is selected under System Setup tab.

 This is for TOOLBOX 12 Software.

Fig. 11.49



- From the top menu bar, go to the System pull-down menu and select Edit Parameters from ECU.  
Figure 11.50.

Fig. 11.50

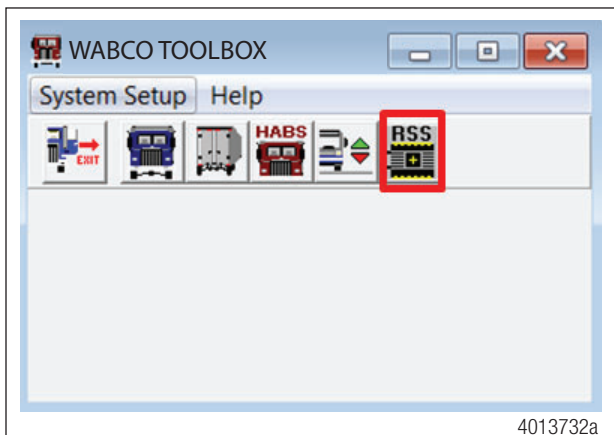
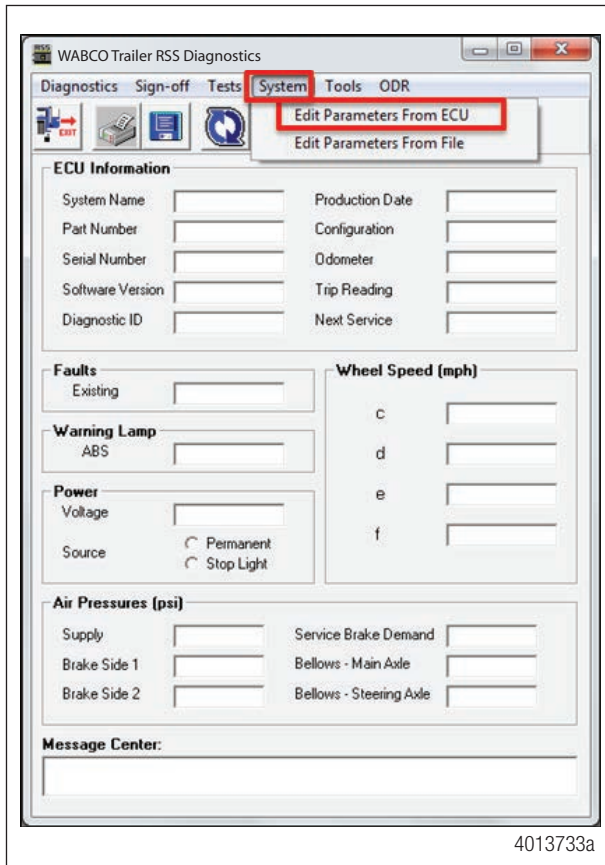

- From the RSS System Parameters screen, verify that the settings are correct, then click Next.  
Figure 11.51.

Fig. 11.51

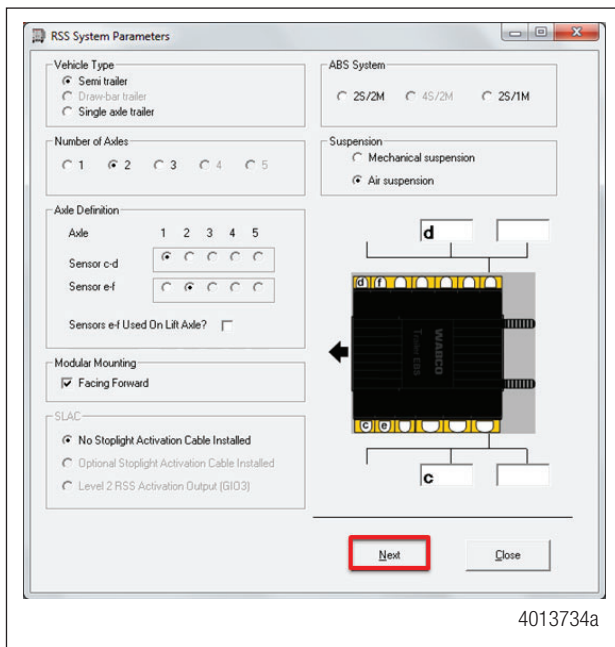

# Troubleshooting

- When the GIO Selection screen is displayed, click both the Tire Inflation Systems and Door Ajar check boxes. Ensure that a check appears in each box. Then, press the Next button at the bottom of the screen. Figure 11.52.

Fig. 11.52

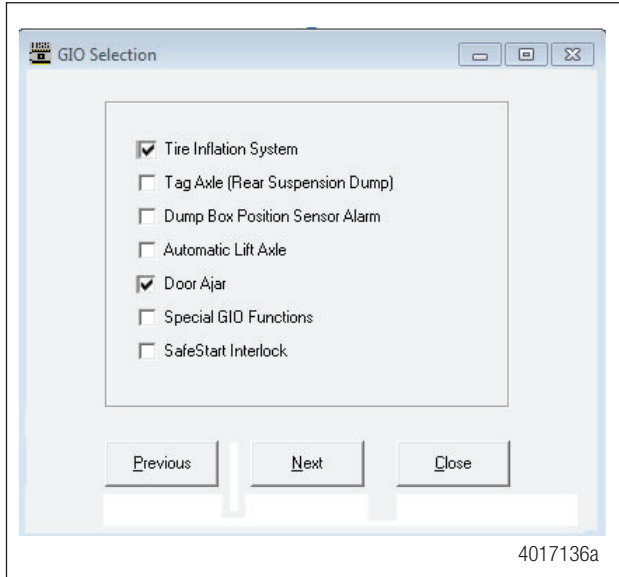

- From the RSS LSV Parameters screen, press the Next button at the bottom of the screen. Please use default settings unless directed otherwise by WABCO. Figure 11.53.

Fig. 11.53

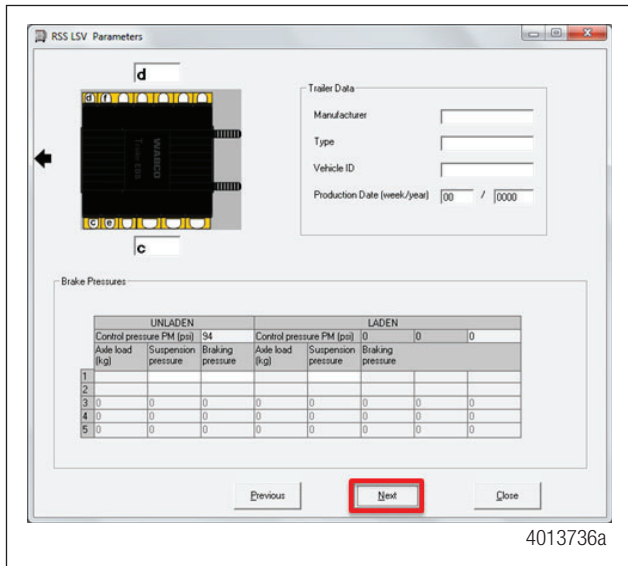

7. From the RSS/ABS Parameters screen, ensure that one of the RSS On options is selected, then press the Save to ECU button at the bottom of the screen. Figure 11.54.

Fig. 11.54

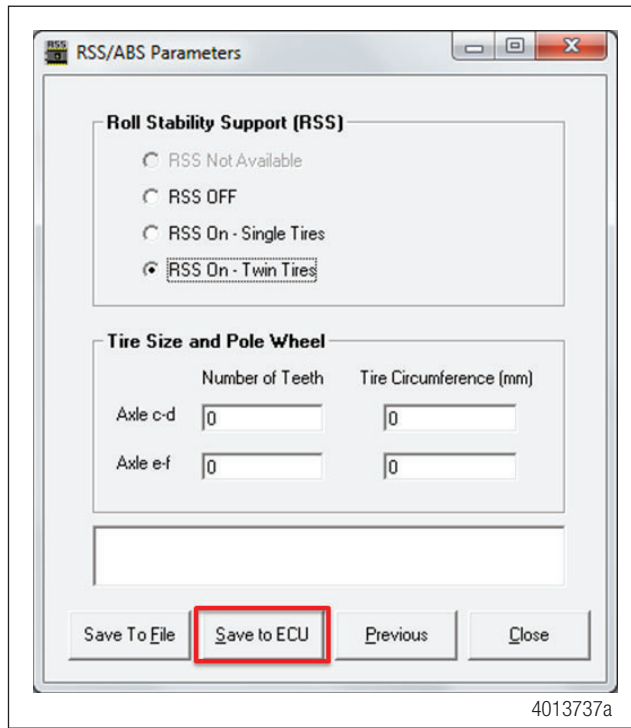

8. Once a message is displayed confirming a successful save, click Exit in the main screen to close the TOOLBOX™ Software.
9. Cycle the power on the trailer in order to reset the ECU.



The End-Of-Line test is required on a new ECU and recommended each time after programming the ECU.

# Appendix

## 12 Appendix

### 12.1 Cable Routing Guidelines

All wires should be tightly secured to a solid member in intervals not greater than 18-inches (457 mm) to avoid excess cable vibration and potential snags with road debris. The correct cable installation should not allow the cable to slide through beam clamps/zip ties, but not tight enough to pinch the internal wires. Refer to technical bulletins TP20212 and TP1593 for more information.

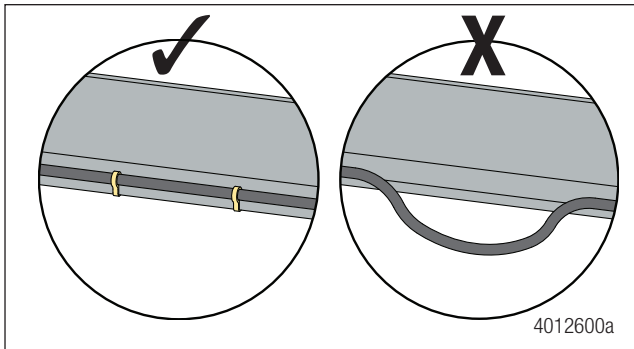

Wiring should NEVER go through any bare, unprotected metal holes. Use grommets, caulk or wire wrap to protect wire from premature wear.

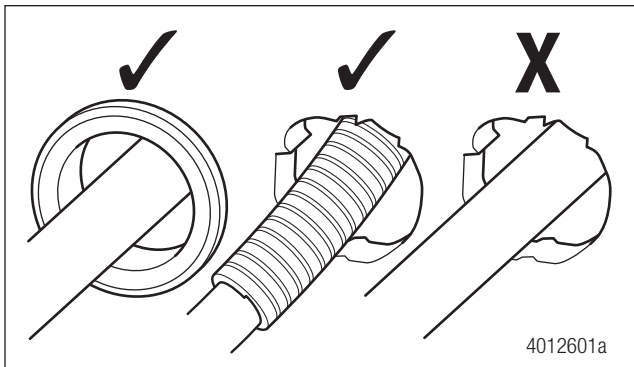

When routing the cable through the wiring channel on the edge or center of the trailer, secure the shorter leg of the latch connectors to the longer leg to ease wire routing.

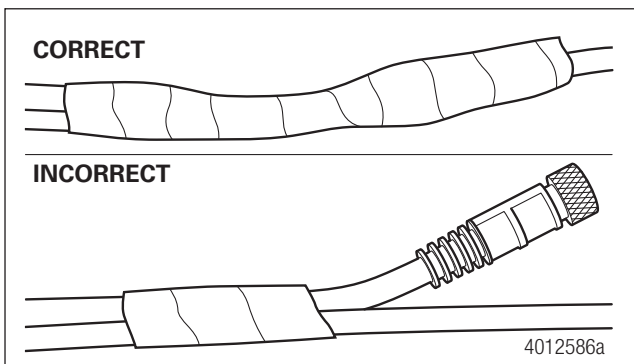

## Appendix

When using a wire snake to pull the cable up through the frame, make sure to tape the connectors correctly to the wire snake.

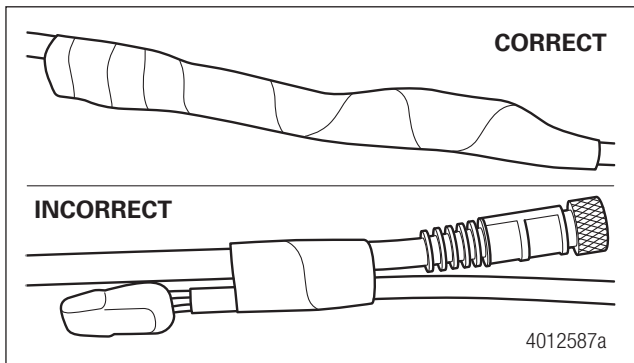

## 12.2 Cable Strain Relief Guidelines

It is important that cabling follows good strain relief practices to ensure maximum performance and durability. Failure to provide adequate strain relief on the cables can result in future maintenance that is not covered under warranty.

Strain relief is defined as a small amount of slack in the cable at the area of connection. This lack of cable tension allows for slight movement of the cable during times when components of the suspension and air system are in motion. A small amount of slack also eases access to other system components.

A taut cable can negatively affect the lifespan of the cable and attached component. Cables without adequate strain relief can potentially stress a cable connection enough that moisture could intrude into the cable connector. Internal wire stress at bend points can be the result of a cable under tension.

Cable strain relief is a universal practice. It applies to all WABCO product lines from Anti-Lock Brake (ABS) systems to Roll Stability Systems (RSS).

### 12.2.1 Excess Cable Length

In cases where the length of cable exceeds what is required, the excess must be bundled in an efficient manner.

- Cables should not be draped or wrapped around components or left unsecured.
- All slack remaining in the cable once the connections are made can be bundled in a Z-shaped loop. Do not coil the cable into a circular bundle.
- The bend at the end of the bundled cable should be greater than or equal to ten times the diameter of the cable.
- All cable fasteners should be tightened in a manner only to the extent that the cable is held sufficiently in place. Over tightening can result in damage to the cable.
- Fasten the excess cable to an area that is free of sharp edges and moving components.

WABCO has many lengths of cables available so it is a best practice to obtain a length that suits the requirements of the installation.



## Appendix

### 12.2.2 Strain Relief at the ECU – Bracket Mounting

It is recommended that cable connections to a component, such as an ECU valve assembly, display a visible amount of slack in the cable up to the first fastener, that secures the cable to trailer structure or air line. This applies to both zip ties or cable clips. This first anchor point should be a minimum 6-inches and a maximum 12-inches of cable length from the cable/component connection. This applies to all sensor, power, valve and GIO cables. Regardless of whether zip ties or cable clips are used, cables should be secured at intervals of a maximum of 18-inches to avoid cable vibration or excess cable that could potentially snag with external objects.

Ideally, cables should be affixed to the rigid structure of the trailer. It is a requirement to have the bend of the cable, also known as bend radius, be greater than or equal to ten times the diameter of the cable. If the cable is one-quarter-inch in diameter, then the bend should be a minimum of 2-1/2-inches.

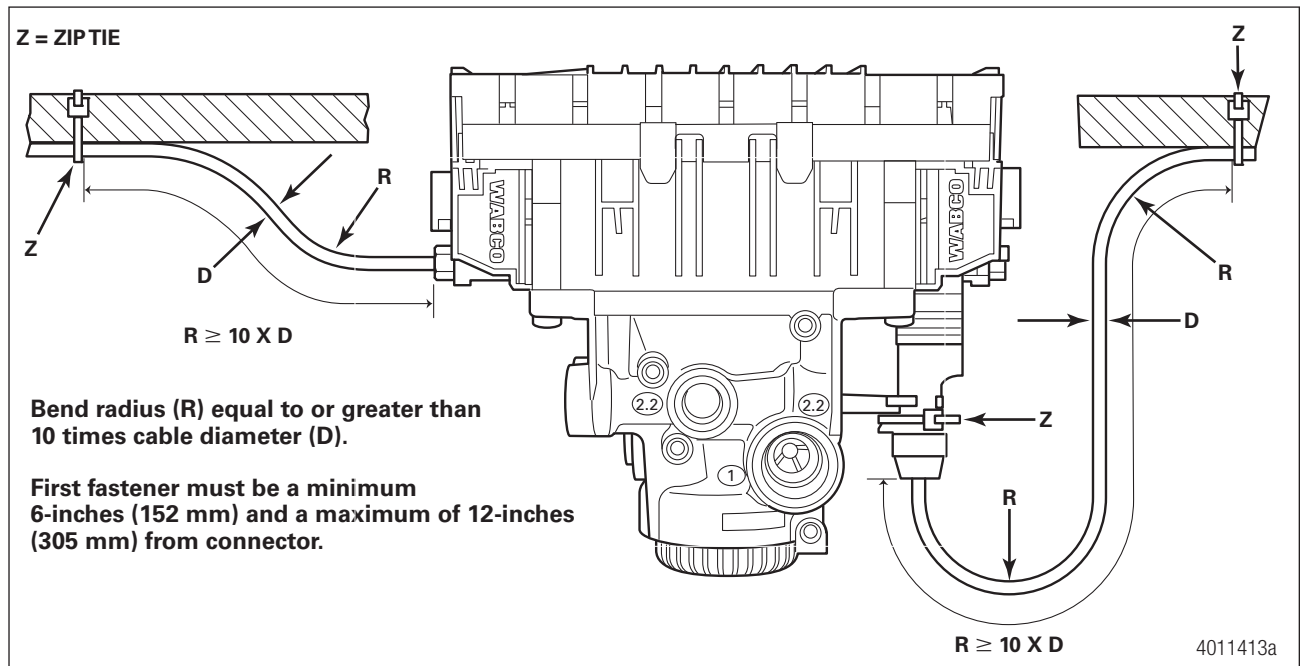

### 12.2.3 Sensor Extension Cables at the ECU

On valves with no trailer structure nearby, the sensor extension cables are attached to the air lines. Cable clips are preferred to zip ties. It is important to remember that cables should be fastened in a manner where the cable is secured enough where the cable will not move or chafe against what it is mounted to. A small amount of slack should be present to ensure that the cables do not become taut after installation or the servicing of components. Figure illustrates correct amount of slack in the sensor extension cables and correct attachment to the air delivery lines for RSS*plus* ECUs.

## Appendix

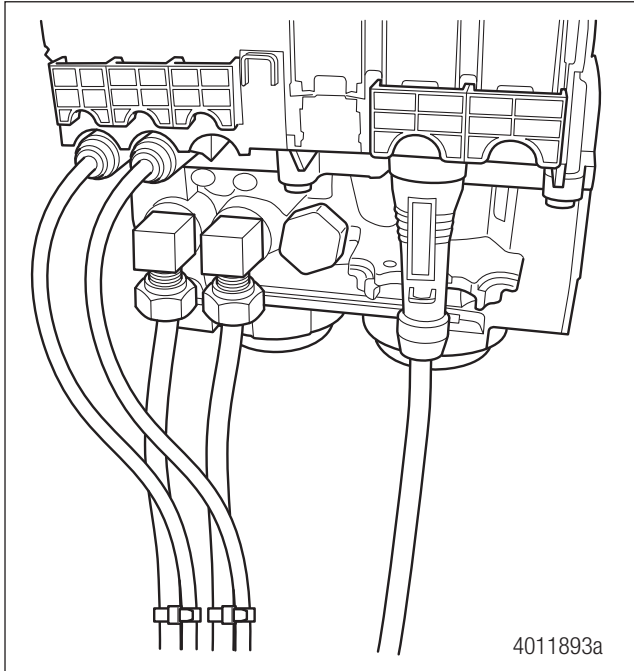

RSS 2M ECU valve assemblies have a zip tie channel on the valve assembly to secure the power cable. Slide the zip tie through the valve assembly's channel and then secure the power cable. When installing a RSS 2M ECU valve assembly, secure the sensor extension cables by fastening them to nearby air lines. It is important to note that an appropriate amount of slack is left in the cables and that cables are secured only to the extent that the cable is held sufficiently in place.

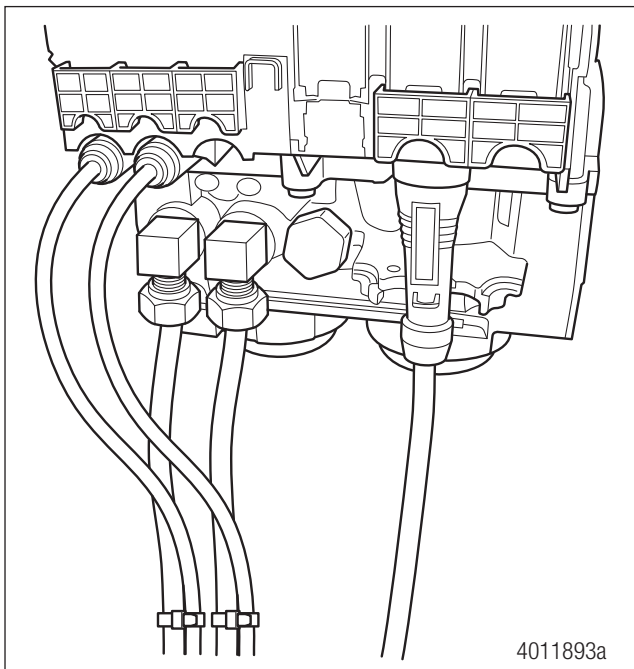

**RSS 2M ZIP TIE PLACEMENT**

## Appendix

### 12.2.4 Placement of Cables on Air Lines — Cable-to-Cable Connections

It is important to ensure all cable-to-cable connections maintain good strain relief. Cable restraints must be placed between two- and four-inches (51-102 mm) from the cable connector to ensure correct strain relief. Regardless of whether zip ties or cable clips are used, cables should be secured at intervals not greater than 18-inches (457 mm) to avoid cable vibration. Refer to figures for air line attachment and axle attachment.

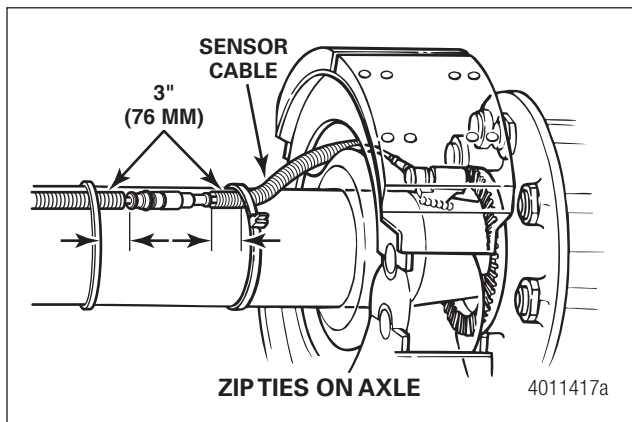
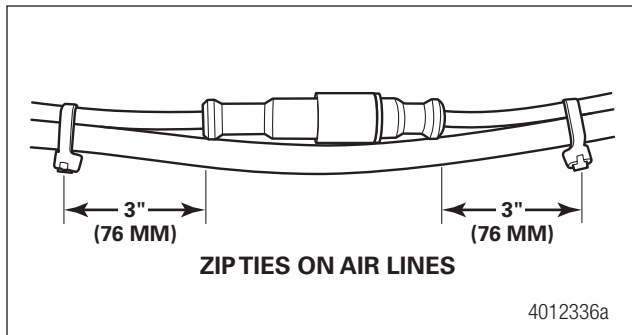

## 12.3 Vehicle Electrical Grounding Guidelines

Ensure that the vehicle includes a correct common chassis ground point. A common chassis ground point connects the trailer frame/ chassis to the ground pin of the J560 seven-way connector and will protect the vehicle electrical system from unwanted electrical noise.

Common chassis ground can be verified by measuring the resistance between the J560 ground pin and the vehicle chassis (or frame) and confirming that the resistance is less than 10 ohm ( $< 10 \Omega$ ). If this is not the case, the electrical contact at the common chassis ground point is not sufficient or not present. If a common chassis ground point is present, but not sufficient, ensure that there is no paint or debris inhibiting electrical contact at the ground point. If a common chassis ground point is not present, WABCO requires adding one. Consult your trailer manufacturer (OEM) for further instructions on how to perform this task. This ensures that the trailer OE warranty is not voided.

# Appendix

## 12.4 Pin Assignment

### 12.4.1 RSSplus

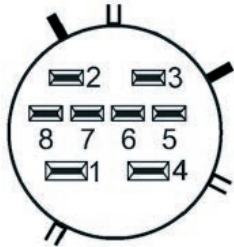
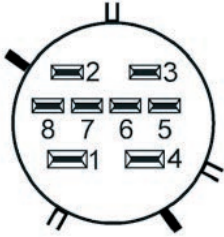
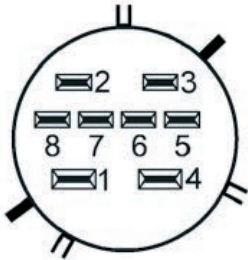
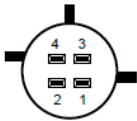
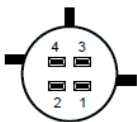
Connections	Pin	RSSplus
<b>MODULATOR, 8-pin Code B, grey</b>		
	1	
	2	
	3	
	4	
	5	
	6	
	7	
	8	
<b>POWER, 8-pin Code A, black</b>		
	1	Power
	2	Stoplight power
	3	Stoplight power
	4	Ground
	5	Warning indicator / warning lamp
	6	
	7	
<b>SUBSYSTEM, 8-pin code C, blue</b>		
	1	Power
	2	CAN2 High 5 V
	3	CAN2 Low 5 V
	4	Ground
	5	GIO power stage 4-2
	6	
	7	
	8	ABS rotational speed sensor c
<b>IN/OUT 4-pin Code C</b>		
	1	SA 3-1
	2	Ground
	3	SAE A
	4	SAE B
<b>ABS e / GIO7, 4-pin Code A/B</b>		
	1	
	2	
	3	ABS rotational speed sensor e
	4	ABS rotational speed sensor e

# Appendix

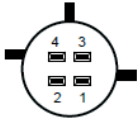
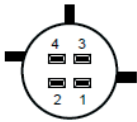
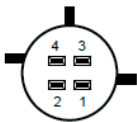
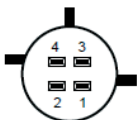
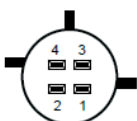
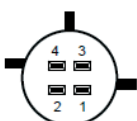
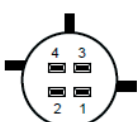
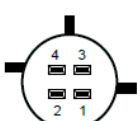
ABS c, 4-pin Code A		
	1	
	2	
	3	ABS rotational speed sensor c
	4	ABS rotational speed sensor c
ABS d, 4-pin Code A		
	1	
	2	
	3	ABS rotational speed sensor d
	4	ABS rotational speed sensor d
ABS f / GIO6, 4-pin Code A/B		
	1	
	2	
	3	ABS rotational speed sensor f
	4	ABS rotational speed sensor f
GIO1, 4-pin Code B		
	1	GIO power stage 1-1
	2	Ground
	3	Analog input 1
	4	Level sensor
GIO2, 4-pin Code B		
	1	GIO power stage 3-2
	2	Ground
	3	
	4	
GIO3, 4-pin Code B		
	1	GIO power stage 1-2
	2	Ground
	3	Analog input 2
	4	
GIO4, 4-pin Code B		
	1	
	2	
	3	
	4	
GIO5, 4-pin Code B		
	1	
	2	
	3	
	4	









**For further details contact the  
WABCO Customer Care Center at 855-228-3203.**

### **About ZF Friedrichshafen AG**

ZF is a global technology company and supplies systems for passenger cars, commercial vehicles and industrial technology, enabling the next generation of mobility. ZF allows vehicles to see, think and act. In the four technology domains Vehicle Motion Control, Integrated Safety, Automated Driving, and Electric Mobility, ZF offers comprehensive solutions for established vehicle manufacturers and newly emerging transport and mobility service providers. ZF electrifies different kinds of vehicles. With its products, the company contributes to reducing emissions and protecting the climate.

ZF, which acquired WABCO Holdings Inc. on May 29, 2020, now has 162,000 employees worldwide with approximately 260 locations in 41 countries. In 2019, the two then-independent companies achieved sales of €36.5 billion (ZF) and \$3.4 billion (WABCO). For more information, visit [www.wabco-na.com](http://www.wabco-na.com).

**WABCO**

Mobilizing Vehicle Intelligence